



**Iron Reduction System**



**MODEL NUMBERS:**

**2P100IRONPRO    2P150IRONPRO    2P200IRONPRO    2P300IRONPRO**  
**2PE100IRONPRO    2PE150IRONPRO    2PE200IRONPRO    2PE300IRONPRO**

# Table of Contents

<b>Pre-installation Instructions</b>	<b>Page 2</b>
<b>General Installation</b>	<b>Page 4</b>
<b>Installation Instructions</b>	<b>Page 6</b>
<b>2P Timer Operation</b>	<b>Page 9</b>
<b>2PE Display and Operation</b>	<b>Page 11</b>
<b>2PE Setting Time of Day</b>	<b>Page 12</b>
<b>2PE Programming</b>	<b>Page 13</b>
<b>Specifications</b>	<b>Page 14</b>
<b>Component Parts Diagram</b>	<b>Page 15</b>
<b>Component Parts List</b>	<b>Page 16</b>
<b>2P Control Valve Diagram</b>	<b>Page 17</b>
<b>2P Control Valve Parts List</b>	<b>Page 18</b>
<b>2PE Control Valve Diagram</b>	<b>Page 19</b>
<b>2PE Control Valve Parts List</b>	<b>Page 20</b>
<b>CKV-1 Coupling Check Valve Installation</b>	<b>Page 21</b>
<b>Troubleshooting</b>	<b>Page 22</b>
<b>2P Control Valve Wiring</b>	<b>Page 24</b>
<b>Warranty</b>	<b>Page 25</b>

# Pre-installation Instructions

## Description of the iron filtration system

The iron filtration system includes an aeration tank, a filtration tank and a backwashing control valve. Incoming water flows into the control valve and is directed into the aeration tank. Exposure to the air in this tank will begin oxidizing any clear water iron. The water then flows through the back connector tube and into the filtration tank where oxidized iron is trapped by the filter media. The iron-free water then returns to the control valve where it is directed into the service lines.

Periodically the control valve will go through a backwash cycle. This cycle will typically begin at 1:00 A.M. flushing the accumulated iron to the drain. Part of this backwashing process includes an air draw cycle which will replenish the pocket of air in the aeration tank and prepare the unit for the next period of service.

## Water Quality

While the filter will perform under a variety of water qualities there are a few things that need to be considered to ensure satisfactory performance. The water should be tested to determine the concentration, or levels of the items listed below.

**pH** - A measurement of the acidity of the water. pH is reported on a scale from 0 to 14. Neutral water has a pH of 7.0, lower values indicate acidic water. The iron filter performs best when the pH is 7.0, or higher. pH values below 7.0 require a special media blend in the filter in order to elevate the pH for proper iron oxidation.

**Iron** - A naturally occurring metallic element. Iron concentrations in excess of 0.3 milligrams/liter (mg/l) combine with oxygen causing orange or red (rust) stains on plumbing fixtures. Iron naturally exists in some water sources in either clear water (ferrous) state, red water (ferric) state or bacterial form. The iron filter is designed to oxidize ferrous iron so it can be removed by mechanical filtration in the ferric state. By removing the available iron in the water, iron bacteria are then inhibited from propagating and forming biomass. Any biomass that forms inside the iron filter is regularly dislodged during the backwash cycle of regeneration.

**Manganese** - A naturally occurring metallic element. Manganese concentrations as low as 0.05 milligrams/liter (mg/l) can combine with oxygen to cause dark brown or black staining on fixtures. Additionally, manganese can cause an odor in the water similar to a "rotten egg" smell. The iron filter reduces manganese as well as iron, however, manganese oxidation requires the pH of the water to be elevated to 8.2 or higher. Special Iron Pro media blends are available to elevate the pH of manganese bearing waters.

**Tannin** - A naturally occurring humic acid. Tannin is an acid caused by water passing through decaying vegetation. Coffee and Tea are prime examples of tannin in water. As hot water passes over the coffee beans, or tea leaves, the tannin is extracted causing color and flavor in the water. Tannin concentrations as low as 0.3 milligrams per liter can cause a yellow discoloration in the water and may interfere with the iron filter's long-term ability to remove the iron as the media becomes coated with the tannic acid.

**Hydrogen Sulfide** - A naturally occurring gas. Hydrogen sulfide, more commonly referred to as sulfur gas, causes a distinct odor similar to "rotten eggs". Due to its gaseous nature, hydrogen sulfide must be tested at the well site within 1 minute of drawing the sample. If a water sample has been sitting for a while the sulfur gas will dissipate and cause the hydrogen sulfide test to be lower than the actual concentration. If sulfur is present, the filter should be set to backwash more frequently to prevent the gas from building up. The iron filter can typically treat up to 2 to 3 milligrams per liter of sulfur gas.

# Pre-installation Instructions (cont.)

## Water Supply

Unlike other iron filters that do not use chemicals to oxidize the iron, the iron filter does not require additional devices such as air compressors, venturis, solenoids, pressure switches or pressure tanks. This filter will function properly when the water supply is furnished by a jet pump, submersible pump, variable speed (constant pressure) pump or community water supply. As with all other filter systems, however, it is imperative that the well pump provides enough flow rate for the filter to adequately backwash. In order to ensure sufficient backwash flow rate the following pumping rate test should be performed prior to installing the iron filter.

1. Make certain no water is being drawn in the house.
2. Open spigot nearest pressure tank.
3. When well pump starts, close spigot and measure time (in seconds) to refill pressure tank (well pump turns back off). This is **Cycle Time**.
4. Using a container of known volume, draw water from pressure tank and measure how many gallons until the pump turns back on again. This is **Draw Down**.
5. Calculate pumping rate by dividing draw down by cycle time and multiplying by 60.

$$\frac{\text{Draw Down (gallons)}}{\text{Cycle Time (seconds)}} \times 60 = \text{Pumping Rate (gallons per minute)}$$

Example: Draw down is 8 gallons  
Cycle time is 65 seconds

$$\frac{8 \text{ gallons}}{65 \text{ seconds}} \times 60 = 7.4 \text{ gpm (gallons per minute)}$$

## Location Considerations

The proper location to install the filter will ensure optimum filter performance and satisfactory water quality. The following factors should be considered in selecting the location of the iron filter.

1. The filter should be installed after the pressure tank (private well system only).
2. The filter should be installed as close as possible (preferably within 15') to an adequate floor or laundry drain capable of handling the backwash cycle volume and flow rate (refer to unit specifications).
3. All water conditioning equipment should be installed prior to the water heater. Water temperatures exceeding 100°F can damage the internal components of the control valve and filter tank. An expansion tank may need to be installed in the line to the water heater in order to allow for thermal expansion and comply with local plumbing codes.
4. The filter should not be subject to freezing temperatures.
5. The filter should be installed before a water softener (if required).
6. Never install a cartridge type filter prior to the iron filter. Any cartridge or in-line filter (if desired) should be installed after both the filter and any softener that might be installed. This will prevent restricting the water flow and pressure available for backwash.
7. Appliances requiring extended periods of continuous or high flow water use (i.e. geothermal heat pumps, swimming pools, lawn irrigation, outside hose bibs, etc.) should bypass the filter and a spring check valve should be installed on the filter inlet to prevent backflow of air from the aeration tank (see installation diagram Fig. 1).

# General Installation

## GENERAL INSTALLATION & SERVICE WARNINGS

The water conditioner is not designed to support the weight of plumbing.

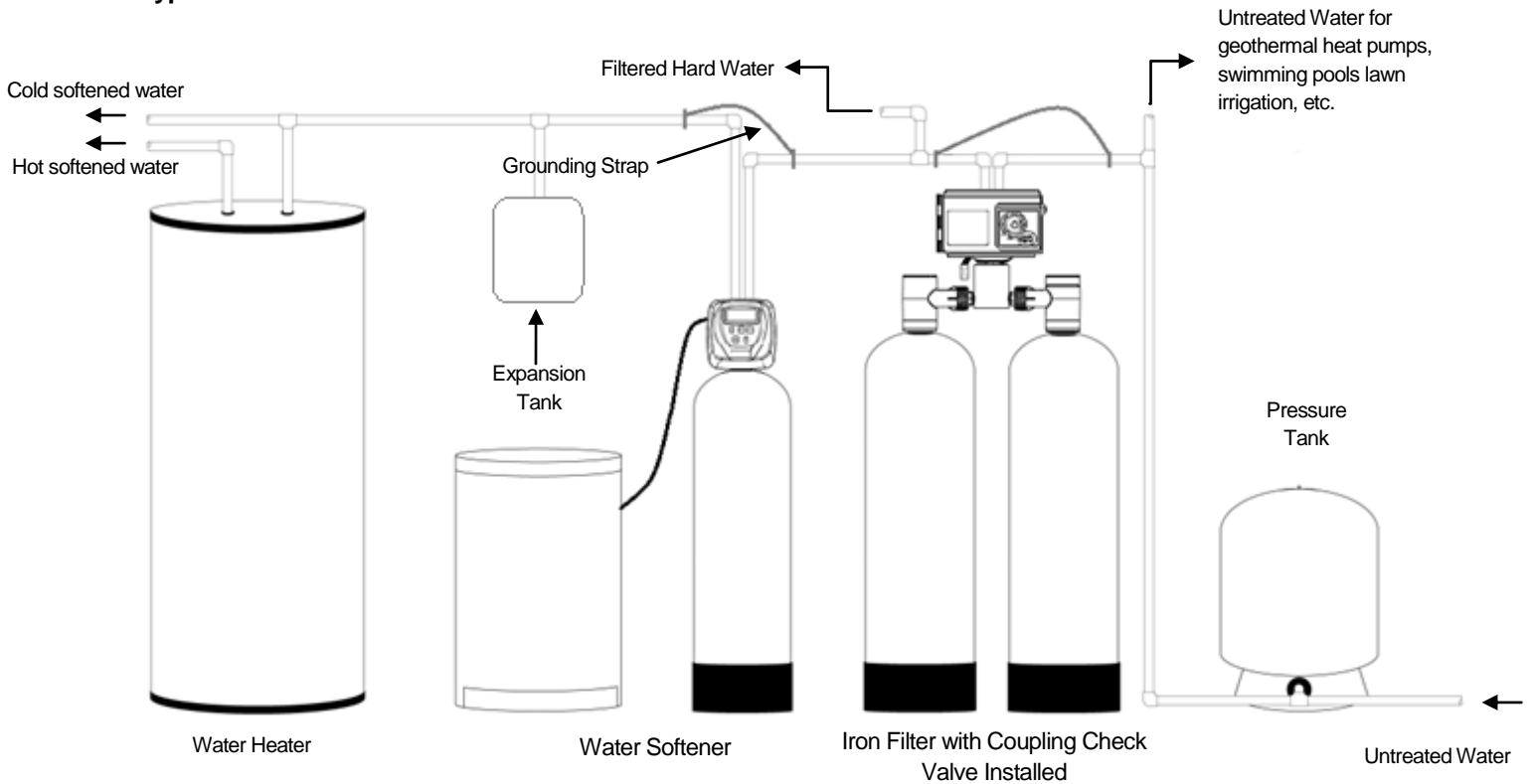
Do not use Vaseline, oils, other hydrocarbon lubricants or spray silicone anywhere. A silicone lubricant may be used on black "O" Rings. This will allow ease of installation and decrease chance of rolling from the bypass and tank connections. *Avoid any type of lubricants, including silicone, on red or clear lip seals.*

Do not use pipe dope or other sealants on threads. Teflon<sup>®</sup> tape must be used on the threads of the drain line connection. Teflon<sup>®</sup> tape is not used on any connection where "O" Ring seals are used

NOTE: If the plumbing system is used as the ground leg of the electric supply, continuity should be maintained by installing ground straps around any non-conductive plastic piping or bypass used in the installation.

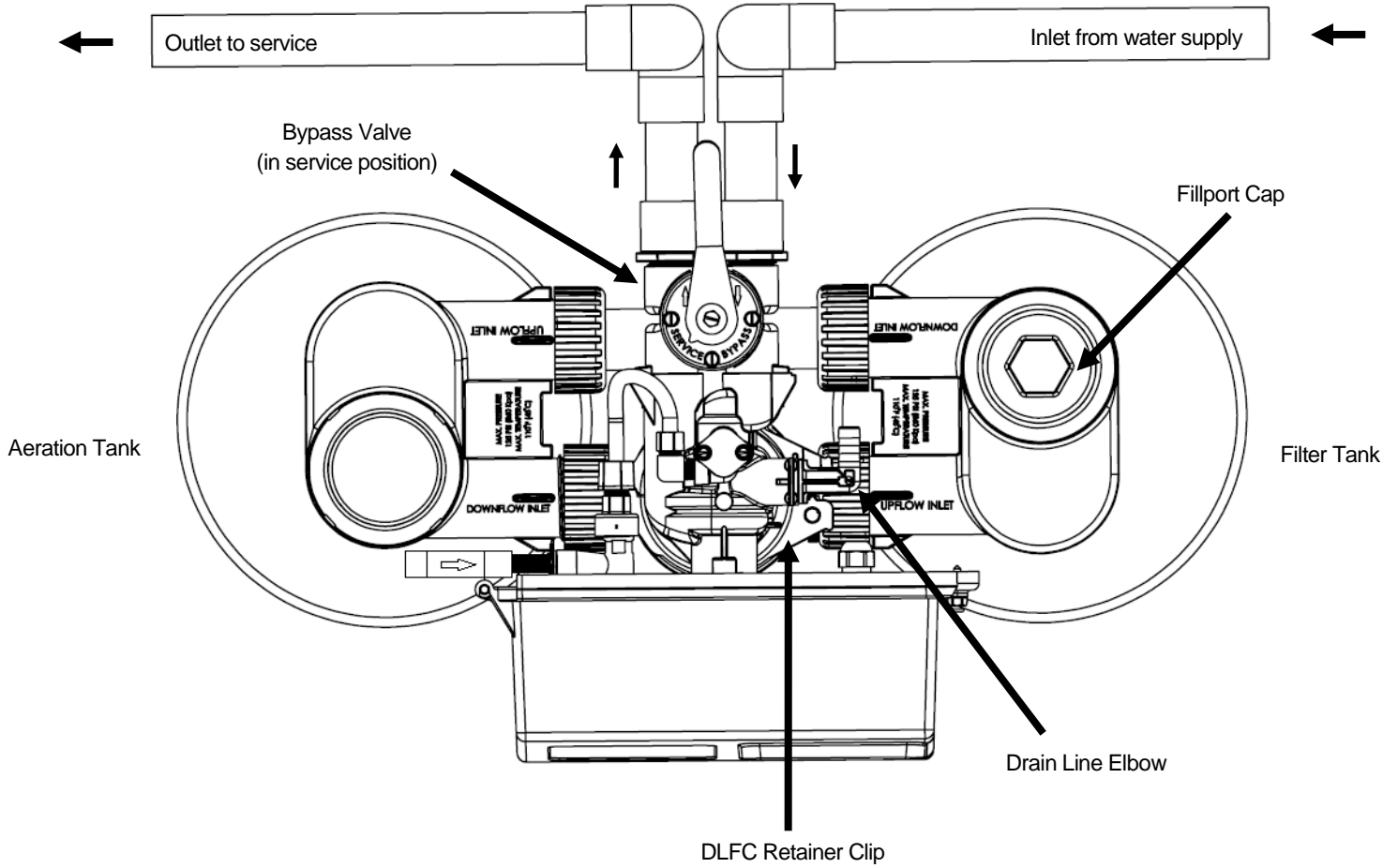
Make sure the filter is not installed backwards. The filter will not function properly if installed backwards and filter media may be forced into the water lines. Arrows molded into the valve body and into the bypass indicate the direction of flow.

### Typical Installation:

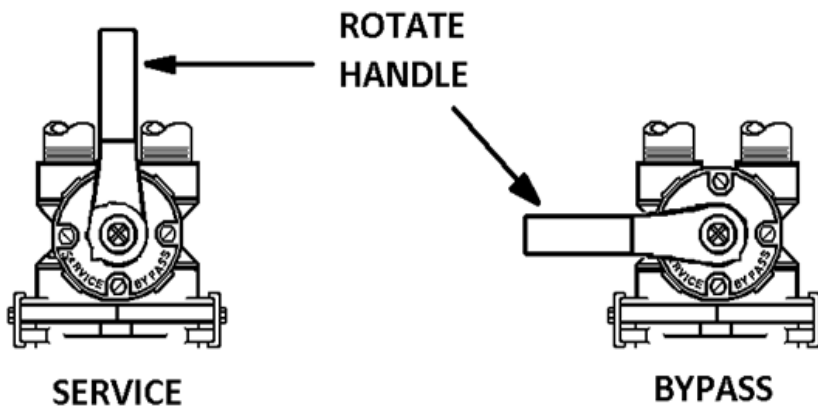


**FIGURE 1: Typical Installation**

# General Installation



**FIGURE 2: Tank Positioning and Fillport Location**



**FIGURE 3: Bypass Valve**

# Installation Instructions

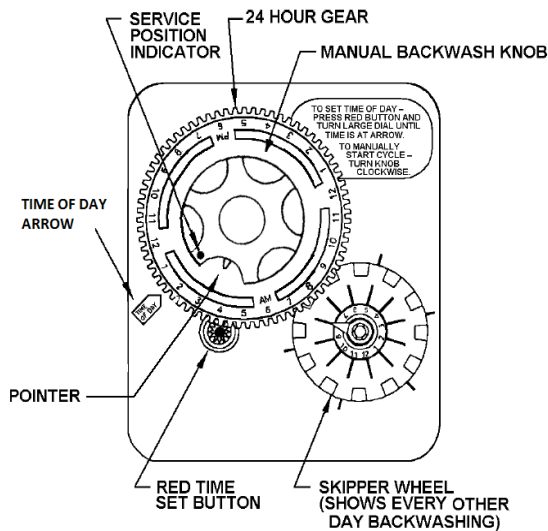
- STEP 1:** If media is already loaded in filter tank proceed to Step 4. Otherwise, use the fillport wrench provided to remove the fillport cap (See Figure 2, page 5) by turning it counter-clockwise.
- STEP 2:** Use the fill funnel provided and add the required amount of media (see unit specifications) to the filter tank. **Do not overfill the tank.** At least 18" of freeboard (empty space) is required at the top of the media tank to allow for proper bed expansion during backwash. Depending on the unit model number, there may be as much as 24" of freeboard. Any excess media may be saved for future replenishment.
- STEP 3:** Clean any media out of the fillport cap threads. **Do not reinstall the fillport cap until Step 10.**
- STEP 4:** Place filter tank on right side with inlet/outlet facing left. Place aeration tank on left with inlet/outlet facing right.
- STEP 5:** Attach the control valve assembly to the front inlet opening of the aeration tank and outlet opening of the filter tank. Attach the straight pipe adapter to the back outlet of the aeration tank and inlet of the filter tank. **HAND TIGHTEN UNION NUTS ONLY. DO NOT OVER TIGHTEN.**
- If there are any branches in the plumbing between the pressure tank and the OXY you must install the CKV-1 coupling check valve and an expansion tank (Figure 1, Page 4). See CKV-1 installation instructions on page 21.**
- STEP 6:** Shut off water at main supply. Relieve pressure by opening nearest faucet. On private well systems, turn off power to pump and drain pressure tank. **SHUT OFF POWER OR FUEL SUPPLY TO WATER HEATER.**
- STEP 7:** Cut main supply line as required to fit plumbing to inlet and outlet of bypass valve. **DO NOT PLUMB INLET AND OUTLET BACKWARDS.** Piping should support control valve in an upright position. Do not apply heat to any fitting attached to the bypass or control valve.
- STEP 8:** Use the provided polyethylene tubing (**NO VINYL TUBING**) to run drain line from control valve discharge fitting to floor drain or sump pit capable of handling the backwash rate of the filter (refer to specifications and flow rate on page 14). **DISCHARGE END OF THE DRAIN LINE MUST BE FIRMLY SECURED!** Failure to properly secure the drain line will result in the drain line "whipping" and possibly flooding the area causing water damage. There must be an air gap at the end of the drain line to prevent siphoning of waste water and meet plumbing code. Total length of drain line should be 15' or less. **AVOID OVERHEAD DRAINS.**
- STEP 9:** Use a garden hose or bucket to fill the media tank with water through the fillport. Ensure media has been cleaned from fillport threads and install cap securely with wrench provided.
- STEP 10:** Plug the transformer into a non-switched electrical outlet.
- Be sure the control valve is in the "Service" position. For the 2P models the service indicator should point to the time of day arrow (See figure 4a, page 7).
- 2PE units are in service when the time of day is displayed above the gallons remaining (see figure 6, page 11).
- The bypass valve should be in the "Bypass" position (See figure 3, page 5). Open main supply valve or turn on power to pump on private well systems. Check for leaks and correct as needed.

# Installation Instructions (cont.)

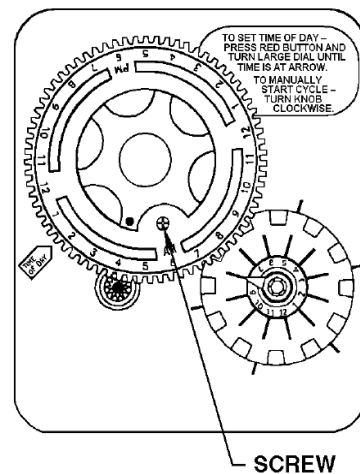
**STEP 11:** Open bypass valve  $\frac{1}{4}$  of the way allowing unit to pressurize slowly. It is normal for air to be trapped in the top part of the aeration tank. Once tanks are pressurized, fully open bypass valve to the “Service” position (See figure 3, page 5).

**STEP 12:** For 2P models, set the Timer Control (Figure 4a) by rotating the Skipper Wheel (Figure 4a) so the red pointer is directly over day 1. Select the days when backwashing will occur by sliding the metal tabs in or out. IN indicates no backwashing will occur on that day, OUT indicates that backwashing will occur on that day. **Factory setting is to initiate backwash every third day.** For 2PE models, refer to “Programming” on page 13 to change the number of days between regenerations.

## BACKWASH TIMER



**FIGURE 4a: Timer in Service Position**



**FIGURE 4b: Adjusting Time of Regeneration**

**STEP 13:** For IronPro 2P/2PE models 100, 150 & 200, set timer so the next backwash will not occur for at least 24 hours. This allows the media to become fully saturated and prevents loss of media to drain during the first backwash.

For IronPro 2P/2PE model 300, the unit must be backwashed to eliminate fine media particles to the drain:

For model 2P300 turn the manual backwash knob (figure 4a) clockwise until the drive gear engages the program wheel and water begins flowing to drain. Immediately unplug the control valve from the power outlet and leave the unit in backwash until the drain water runs clear. Then plug the control valve back into the power outlet and allow the regeneration cycles to complete automatically before continuing to step 14.

For model 2PE300 hold down the middle (Advance) button (figure 6, page 12) until “GO TO BW” is displayed. Once the unit is counting down the backwash cycle time, immediately unplug the control valve from the power outlet and leave the unit in backwash until the drain water runs clear. Then, plug the control valve into the power outlet again and press the middle (Advance) button briefly, “GO TO DR” will display. Allow the regeneration cycles to complete automatically before continuing to step 14.

## Installation Instructions (cont.)

**STEP 14:** Set the current time of day. For the 2P models start by depressing the red Time Set Button (Figure 4a) and turning the 24 Hour Gear (Figure 4a) to the desired time (note AM and PM).

For the 2PE models refer to "2PE Setting Time of Day" on page 12.

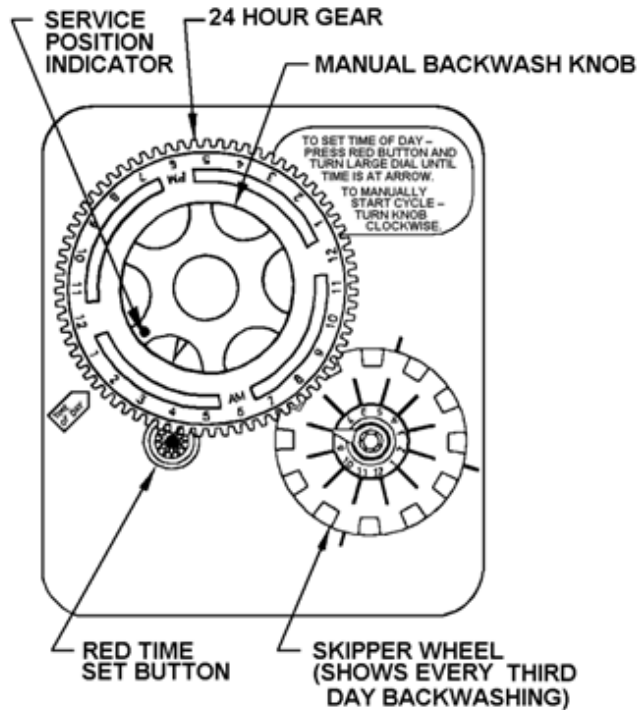
**STEP 15:** Time of Regeneration is factory set to 1:00 A.M. Ensure time of regeneration does not interfere with other water treatment equipment. To adjust the time of regeneration for 2P models:

- a) Unplug control valve from electrical outlet
- b) Locate three screws (Figure 4b) behind the Manual Backwash Knob (Figure 4a) by pushing the red Time Set Button (Figure 4a) and rotating the 24 Hour Gear (Figure 4a) until each screw appears in the cut out portion of the Manual Backwash Knob.
- c) Loosen each screw slightly to release pressure on the 24 Hour gear time plate.
- d) Continue depressing the red Time Set Button and rotate the 24 Hour Gear to expose the Regeneration Time Pointer (Figure 4a) in the cut out portion of the Manual Backwash Knob. Keep the Regeneration Time Pointer visible in the cut out while rotating only the time plate until the desired time of regeneration (note AM and PM) is aligned with the Regeneration Time Pointer. **NOTE: subtract 136 minutes from the desired time for the start of backwash to determine where the Regeneration Timer Pointer should point.**
- e) Continue depressing the red Time Set Button and rotate the 24 Hour Gear along with the Time Plate until each screw has been exposed in the cut out portion of the Manual Backwash Knob and re-tightened. **DO NOT OVERTIGHTEN.** Make certain that the backwashing filter **DOES NOT** regenerate at the same time with any other water treatment equipment.

To adjust the time of regeneration for the 2PE models see "2PE Programming" on Page 13.

**STEP 16:** Turn power or fuel supply back on to water heater.

# 2P Timer Operation



**FIGURE 4: Front of Timer Assembly**

## How to set Time of Day:

1. Press and hold the red button to disengage the drive gear.
2. Turn the large 24 hour gear until the actual time of day is at the time of day pointer.
3. Release the red button to again engage the drive gear.

## How to set the Days of Backwash:

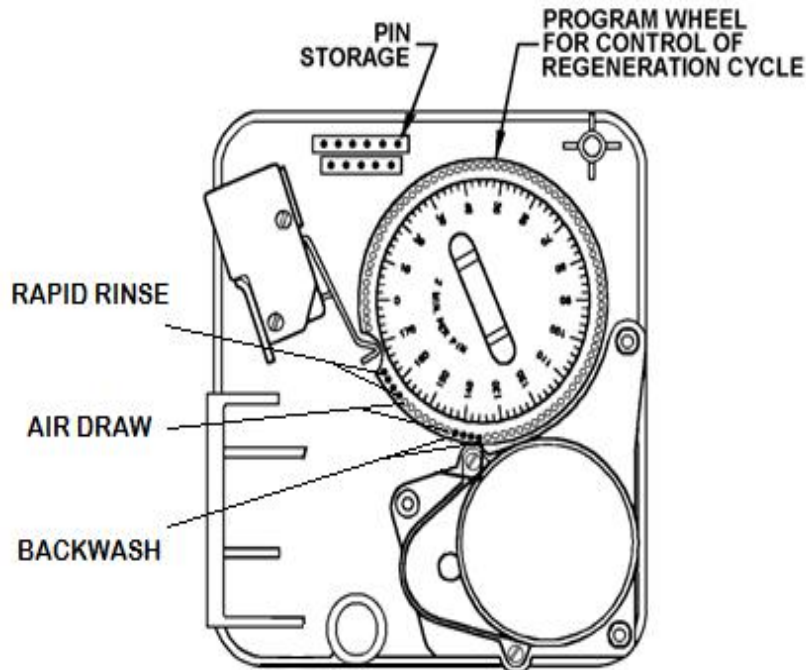
1. Rotate the skipper wheel until the number 1 is at the red pointer.
2. Each number represents a day. The number by the red pointer is tonight.
3. Slide the metal tabs outward on the desired days of regeneration.

The iron filter should be set to backwash a minimum of every third day. Ensure the filter does not backwash for the first two days of operation to prevent media from being backwashed to the drain.

## How to Manually Initiate a Backwash Cycle:

1. Grab the manual regeneration knob and turn clockwise.
2. The drive gear will engage the program wheel and make a complete revolution through the backwash cycle.
3. The backwash knob will make a complete revolution and return to the home position after the backwash cycle.

## 2P Timer Operation



**FIGURE 5: Back of Timer Assembly**

### How to Change the Length of Backwash Cycles:

All cycles have been factory set and should not need adjustment. If local conditions require different cycle lengths, however, the following procedures should be followed. The end of the program wheel has been used for backwash cycles to minimize the amount of time that pressure will be applied to the air draw check valve.

1. Grasp top left corner of timer assembly and pull to swing timer open and expose the program wheel.
2. Remove program wheel from timer by squeezing retaining lugs in center of program wheel. Maneuver program wheel away from micro switch arms and timer assembly.
3. RAPID RINSE cycle may be lengthened by adding pins at the end of the program wheel. Each pin represents 2 minutes of rapid rinse time. The rapid rinse time **MUST** only be increased by shifting both the backwash pins and air draw holes an equal number of positions counter-clockwise on the program wheel.
4. AIR DRAW cycle may be lengthened by increasing the number of holes between the two sets of pins. Each hole represents 2 minutes of air draw time. The air draw time **MUST** only be increased by moving the backwash pins counter-clockwise on the program wheel. Ensure that lengthening the air draw time does not decrease either the backwash or rapid rinse times.
5. BACKWASH cycle may be lengthened by adding pins in a counter-clockwise direction to first set of pins on program wheel. Each pin will equal 2 minutes of backwash time. Ensure that adding pins does not decrease air draw time.
6. Reinstall the program wheel on the retaining lugs by maneuvering past the micro switch arms.
7. Close and latch the timer assembly. Ensure that the retainer snaps into the hole in the backplate and all electrical wiring is **ABOVE** the timer post.

## 2PE Display and Operation

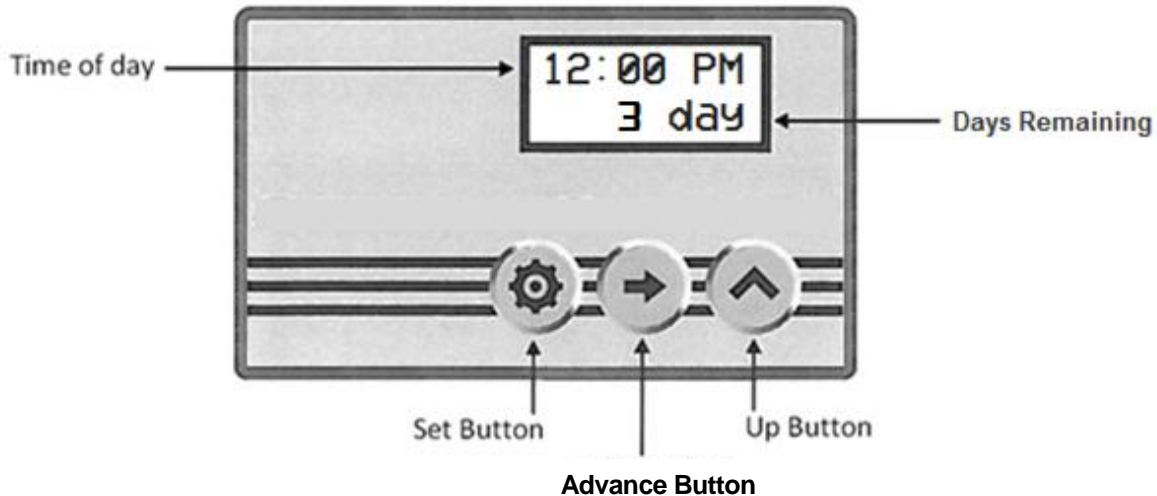


FIGURE 6: 2PE Display Panel



### SET BUTTON

1. Press and hold "Set Button" for 5 seconds to enter Programming Mode.
2. When valve is in Programming Mode, press "Set Button" to confirm setting and advance to next menu option.



### ADVANCE BUTTON

1. Press and hold "Advance Button" for 5 seconds to initiate an immediate regeneration cycle.
2. Press and release "Advance Button" during a regeneration cycle to immediately advance the valve to the next step in the regeneration process.
3. When the valve is in Programming Mode, press the "Advance Button" to move the cursor.



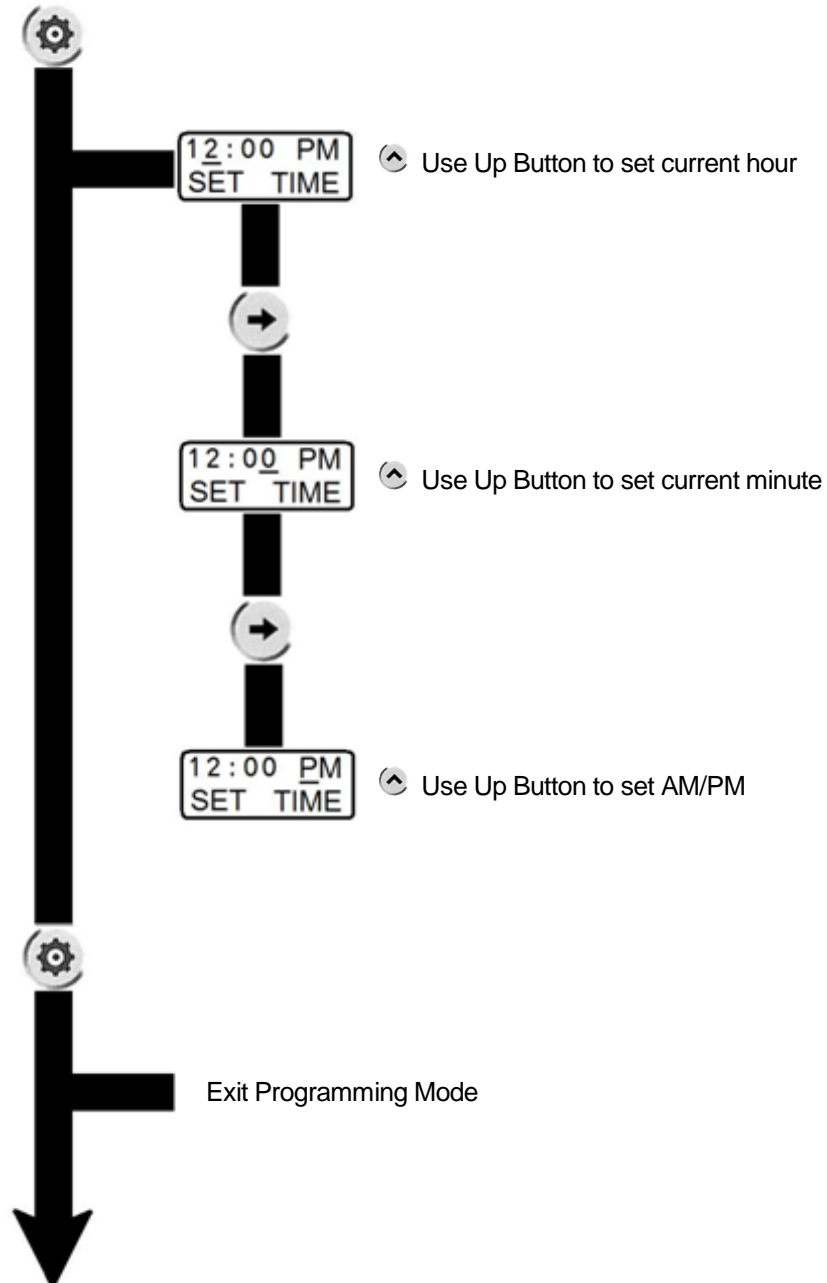
### UP BUTTON

1. When the valve is in the Programming Mode, press "Up Button" to adjust setting.

## 2PE Setting Time of Day

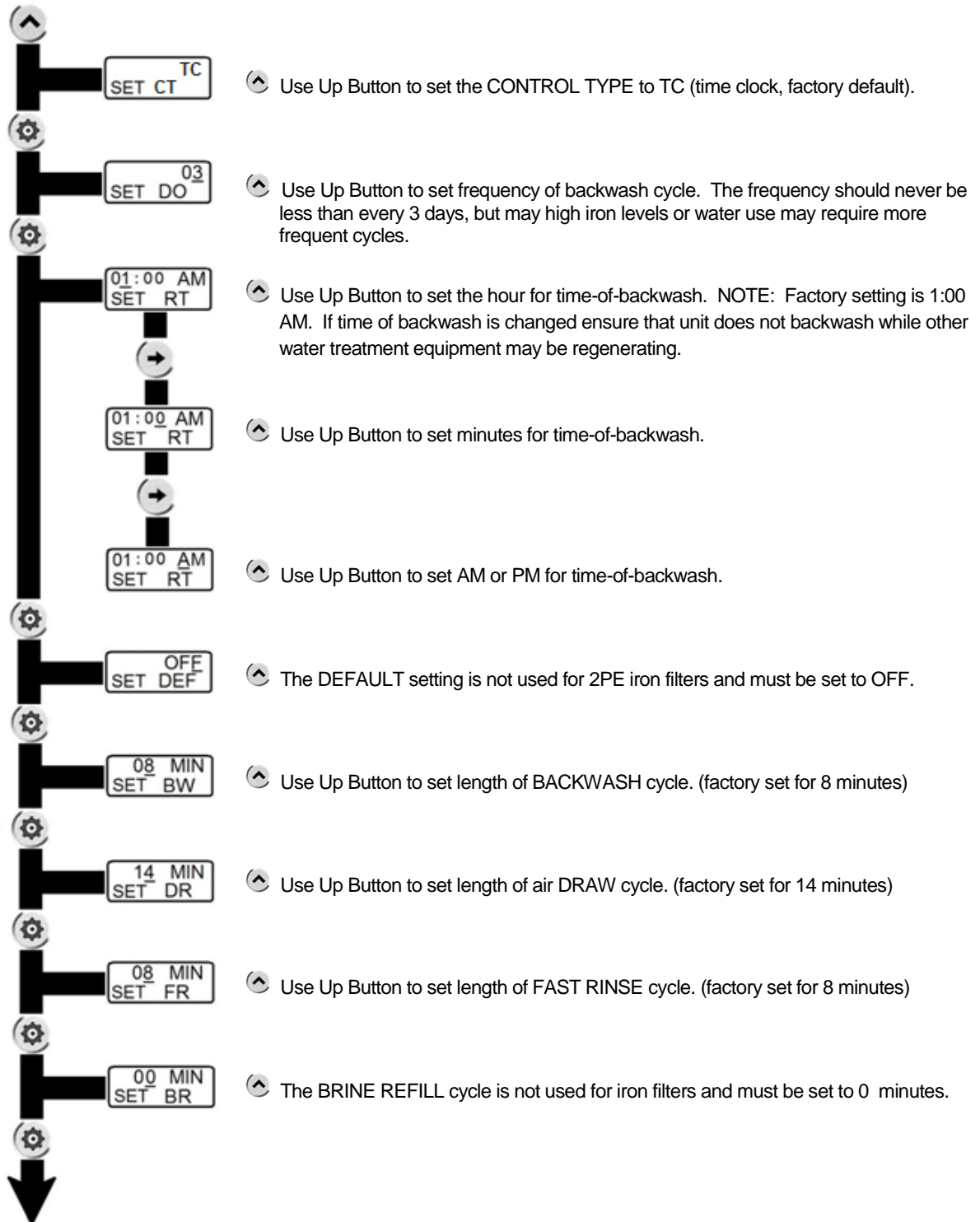
### Enter Programming Mode:

Press and Hold the SET Button for 5 seconds.



# 2PE Programming

Press and HOLD the UP button for 5 seconds to enter the programming mode.



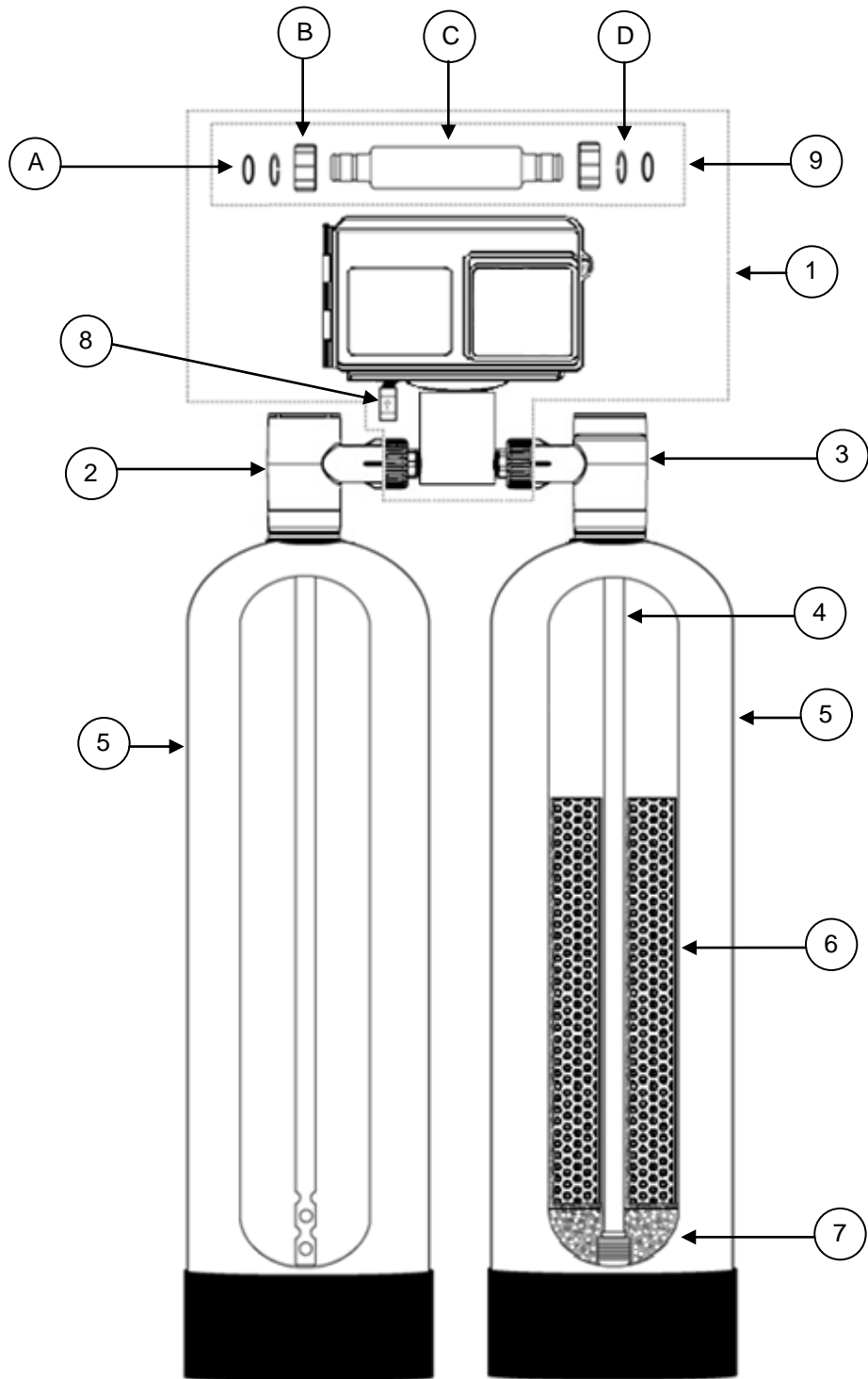
# Specifications

DESCRIPTION	IRONPRO UNIT MODEL NUMBER			
	2P100	2P150	2P200	2P300
<b>MEDIA VOLUME, cu. ft.</b>	1.0	1.5	2.0	3.0
<b>GRAVEL UNDERBED, lbs.</b>	20	20	25	50
<b>SERVICE FLOW RATES, gpm</b>				
Continuous @ 6 gpm/ft <sup>2</sup> , gpm	3	3	5	6
Service @ 12 gpm/ft <sup>2</sup> , gpm	7	7	9	11
Peak @ 18 gpm/ft <sup>2</sup> , gpm	10	10	14	19
<b>PRESSURE LOSS<sup>1</sup>, psi</b>				
@ Continuous Flow Rate	5	7	7	8
@ Peak Flow Rate	10	15	13	20
<b>REGENERATION FLOW RATES, gpm</b>				
Backwash	5.0	5.0	7.0	9.0
Air Draw and Slow Rinse	0.9	0.9	0.9	0.9
Rapid Rinse	5.0	5.0	7.0	9.0
<b>SERVICE PIPE SIZE, in.</b>	1	1	1	1
<b>FACTORY REGENERATION SETTINGS</b>				
Backwash, minutes	8	8	8	8
Air Draw & Rinse, minutes	14	14	14	14
Rapid Rinse, minutes	8	8	8	8
Total Water Used, gallons	93	93	125	157
<b>DIMENSIONS, in.</b>				
Mineral Tank, diameter x height	10 x 54	10 x 54	12 x 48	14 x 65
Overall, length x width x height	28 x 14 x 73	28x 14 x 73	30 x 16 x 67	39 x 18 x 85
DESCRIPTION	UNIT MODEL NUMBER			
	2PE100	2PE150	2PE200	2PE300
<b>MEDIA VOLUME, cu. ft.</b>	1.0	1.5	2.0	3.0
<b>GRAVEL UNDERBED, lbs.</b>	20	20	25	50
<b>SERVICE FLOW RATES, gpm</b>				
Continuous @ 6 gpm/ft <sup>2</sup> , gpm	3	3	5	6
Service @ 12 gpm/ft <sup>2</sup> , gpm	7	7	9	11
Peak @ 18 gpm/ft <sup>2</sup> , gpm	10	10	14	19
<b>PRESSURE LOSS<sup>1</sup>, psi</b>				
@ Continuous Flow Rate	5	7	7	8
@ Peak Flow Rate	10	15	13	20
<b>REGENERATION FLOW RATES, gpm</b>				
Backwash	5.0	5.0	7.0	9.0
Air Draw and Slow Rinse	0.9	0.9	0.9	0.9
Rapid Rinse	5.0	5.0	7.0	9.0
<b>SERVICE PIPE SIZE, in.</b>	1	1	1	1
<b>FACTORY REGENERATION SETTINGS</b>				
Backwash, minutes	8	8	8	8
Air Draw & Rinse, minutes	14	14	14	14
Rapid Rinse, minutes	8	8	8	8
Total Water Used, gallons	93	93	125	157
<b>DIMENSIONS, in.</b>				
Mineral Tank, diameter x height	10 x 54	10 x 54	12 x 48	14 x 65
Overall, length x width x height	28 x 14 x 73	28x 14 x 73	30 x 16 x 67	39 x 18 x 85

**GENERAL REQUIREMENTS:**

Water Temperature	33°F - 100°F
Water Pressure	25 - 100 psi
Electrical Requirements	110v/60hz

# Component Parts Breakdown

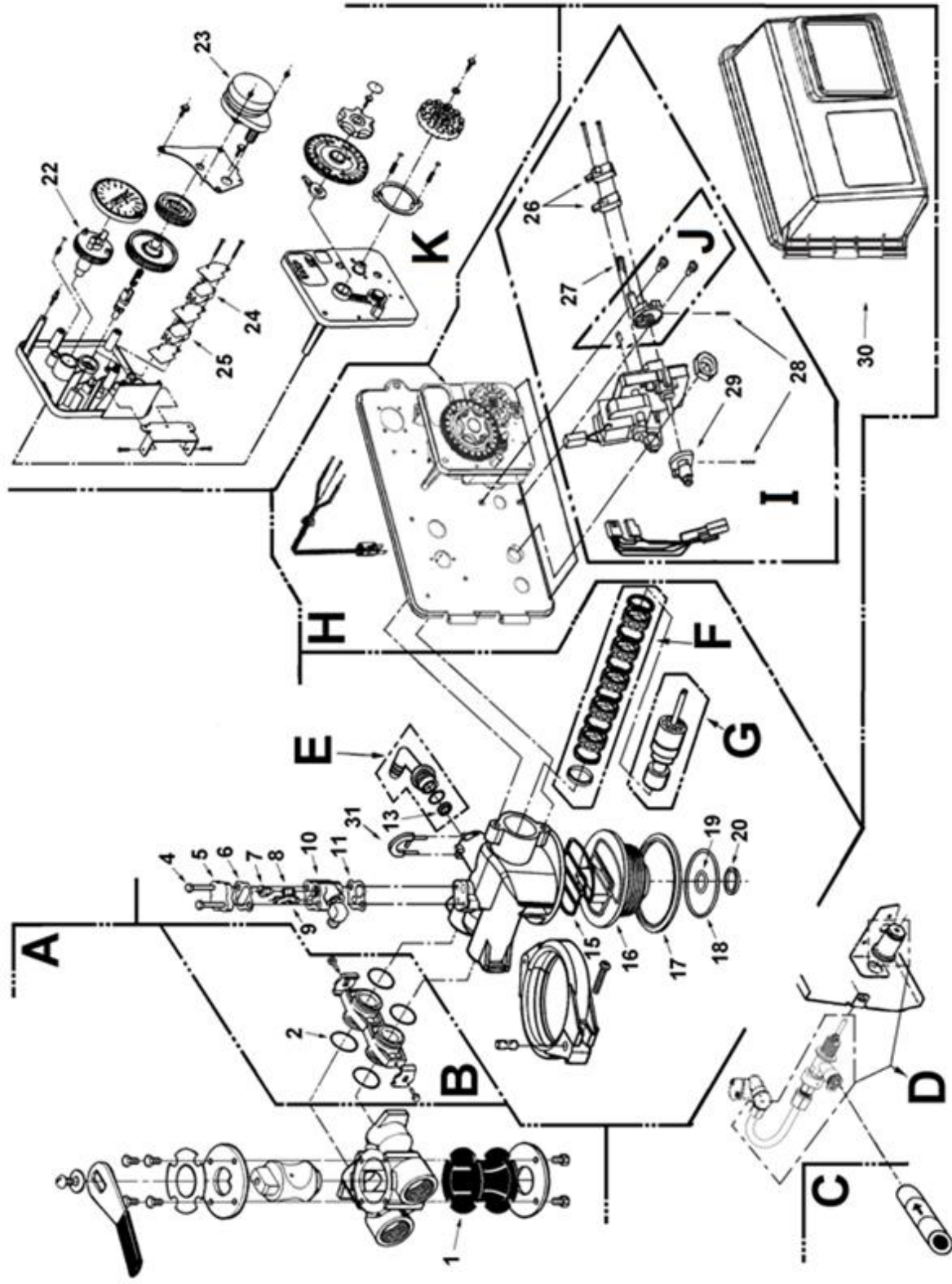


# Component Parts List

Ref #	Part Number	Description
A	OR324	O-Ring, -324
B	C102	Connector Nut
C	DTC204-8	Dual Tank Connector (2P & 2PE models: 100,150, 200)
	DTC204-15	Dual Tank Connector (2P & 2PE model 300)
D	C101	Split Ring Retainer
1	2P100 VLV ASSY W/BP	Complete Control Valve, includes backtube assy & bypass valve (2P models 100 & 150)
	2P200 VLV ASSY W/BP	Complete Control Valve, includes backtube assy & bypass valve (2P200)
	2P300 VLV ASSY W/BP	Complete Control Valve, includes backtube assy & bypass valve (2P300)
	2PE100 VLV ASSY W/BP	Complete Control Valve, includes backtube assy & bypass valve (2PE models 100 & 150)
	2PE200 VLV ASSY W/BP	Complete Control Valve, includes backtube assy & bypass valve (2PE200)
	2PE300 VLV ASSY W/BP	Complete Control Valve, includes backtube assy & bypass valve (2PE300)
2	DH207	Distributor Head
3	FP207	Distributor Head w/Fillport
4	D100S-54	Distributor Tube, 1" x 54" (2P & 2PE models 100 & 150)
	D100S-48	Distributor Tube, 1" x 48" (2P & 2PE model 200)
	D100S-65	Distributor Tube, 1" x 65" (2P & 2PE model 300)
5	MTP1054N	Mineral Tank, 10" x 54" (2P & 2PE models 100 & 150)
	MTP1248N	Mineral Tank, 12" x 48" (2P & 2PE model 200)
	MTP1465N	Mineral Tank, 14" x 65" (2P & 2PE model 300)
6*	OXY05P	½ cubic foot pail OXY Media Blend (2P & 2PE models 100, 150 & 200)
	IP05	½ cubic foot pail Iron Pro Media Blend (2P & 2PE model 300)
7	QC20	20 pounds ¼" x 1/8" gravel (2P & 2PE models 100, 150 & 200)
	QC50	50 pounds ¼" x 1/8" gravel (2P & 2PE model 300)
8	JG-38CV	3/8" Check Valve
9	DTC204-8	Back Tube Assembly, includes 2 each o-rings (A), quick release nuts (B), and retainers (D) and 1 back tube (C) (2P & 2PE models 100, 150 & 200)
	DTC204-15	Back Tube Assembly, includes 2 each o-rings (A), quick release nuts (B), and retainers (D) and 1 back tube (C) (2P & wPE model 300)

\*Refer to unit specifications for quantity of media required.

# 2P Control Valve Breakdown

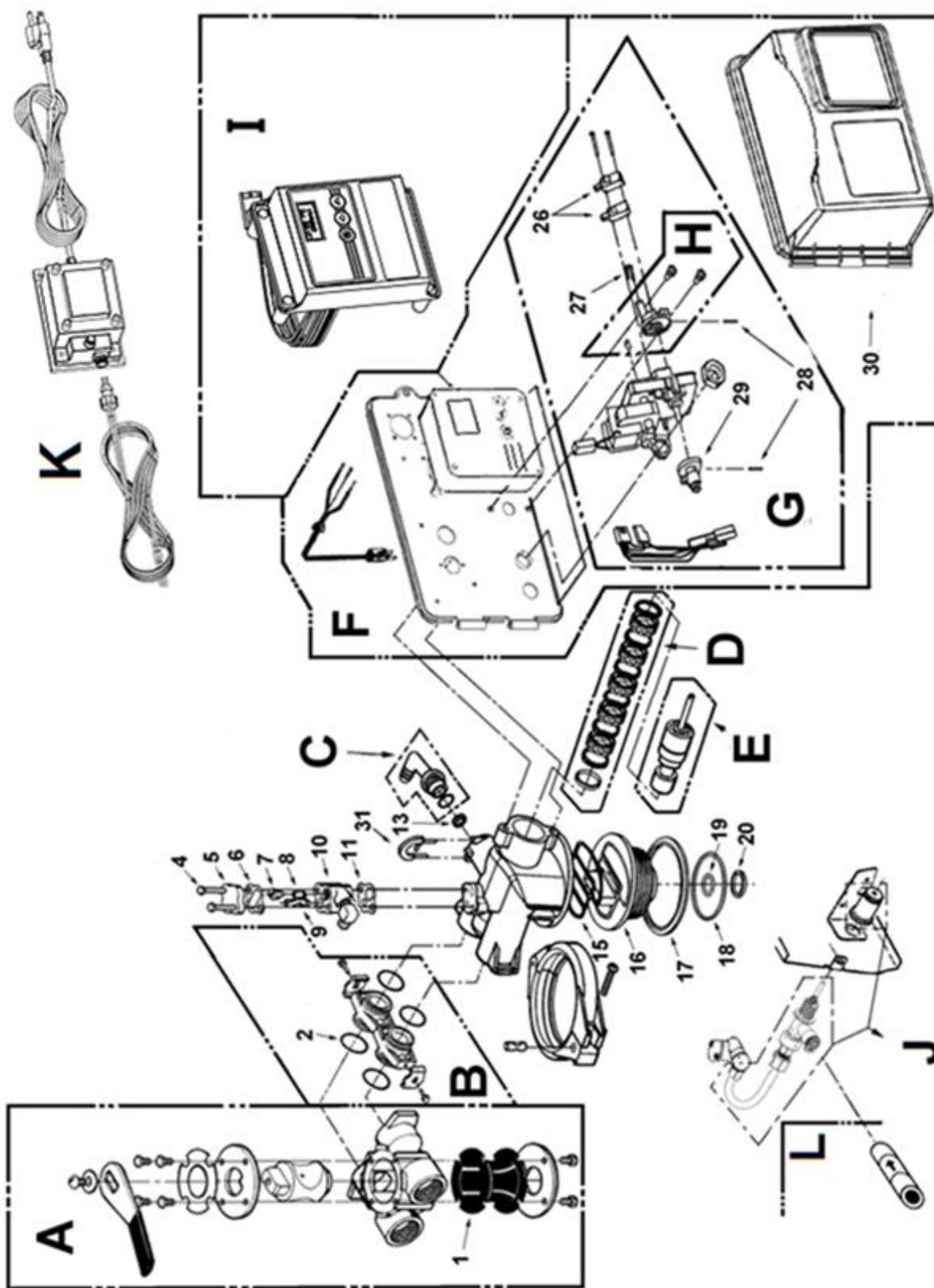


## 2P Control Valve Parts List

REF #	Part Number	Description
A	60041SS	Stainless Steel Bypass, 1" FPT
B	60900-41	Coupling Kit
C	JG-38CV	Check Valve, 3/8" Tube
D	60011-050ASSY	Brine Valve, 1650 Short Stem, 0.5 BLFC with Tube
E	60705-50A	5.0 gpm DLFC Elbow (2P100 & 2P150)
	60705-70A	7.0 gpm DLFC Elbow (2P200)
	60705-00A	Blank DLFC Elbow (2P300)
F	60121	Seal and Spacer Kit
G	60090	Piston Assembly
H	FV2510-1PH	Power Head Assembly, 2510 TC with Cover
I	60050-21	Drive Motor Assembly
J	60160-10	Drive Cam Assembly, STF
K	60304-13	Timer Assembly, 3200, 12 Day, STF, 120/60
1	14105	Bypass Valve Seal, Single Lever
2	13305	Coupling O-Ring, -019
4	10692	Injector cover screw 2510 valve
5	11893	Injector Cover
6	14805	Injector Body Gasket
7	10913-2	Injector Nozzle, #2, Blue
8	10914-2	Injector Throat, #2, Blue
9	10227	Injector Screen
10	17776/10328	Injector Body Plastic w/ o-ring & brass elbow

REF #	Part Number	Description
Not Shown	21257253	O-ring for PN: 17776/10328
11	14805	Injector Body Gasket
13	12092	5.0 gpm DLFC (2P100 & 2P150)
	12408	7.0 gpm DLFC (2P200)
	-NA-	Not used on 3 ft <sup>3</sup> and larger units (2P300)
15	19936	Base Seal (2510)
16	19322	2510 Adapter Base
17	19197	Slip Ring
18	18303	Tank O-Ring, 2510 Valve
19	13304	Distributor O-Ring, -121
20	13030	Distributor Retainer
22	13911	Main Drive Gear
23	18743-1	Timer Motor, 120v/60Hz, 2510/5600 Valve
24	15320	Micro Switch, Homing
25	10896	Micro Switch, Step
26	10218	Micro Switch, Drive Motor
27	10909	Connecting Link Pin
28	10338	Roll Pin
29	12777	Brine Cam, STF
30	SCA-925	Environmental Cover
31	18312	Retainer Clip, Drain

# 2PE Control Valve Breakdown



## 2PE Control Valve Parts List

REF #	Part Number	Description
A	60041SS	Stainless Steel Bypass, 1" FPT
B	60900-41	Coupling Kit
C	60705-50A	5.0 gpm DLFC Elbow (2PE100 & 2PE150)
	60705-70A	7.0 gpm DLFC Elbow (2PE200)
	60705-00A	Blank DLFC Elbow (2PE300)
D	60121	Seal and Spacer Kit
E	60090	Piston Assembly
F	FV2510E-1PH	Power Head Assembly, 2510 E with Cover
G	60050-23	Drive Motor Assembly
H	60160-10	Drive Cam Assembly, STF
I	60308-13	2510E Timer Assembly
J	60011-050ASSY	Brine Valve, 1650 Short Stem, 0.5 BLFC with Tube
K	FE-TRANS	Transformer
L	JG-38CV	Check Valve, 3/8" Tube
1	14105	Bypass Valve Seal, Single Lever
2	13305	Coupling O-Ring, -019
4	10692	Injector cover screw 2510 valve
5	11893	Injector Cover
6	14805	Injector Body Gasket
7	10913-2	Injector Nozzle, #2, Blue

REF #	Part Number	Description
8	10914-2	Injector Throat, #2, Blue
9	10227	Injector Screen
10	17776/10328	Injector Body Plastic w/ o-ring & brass elbow
Not Shown	21257253	O-ring for PN: 17776/10328
11	14805	Injector Body Gasket
13	12092	5.0 gpm DLFC (2PE100 & 2PE150)
	12408	7.0 gpm DLFC (2PE200)
	-NA-	Not used on 3 ft <sup>3</sup> and larger units (2PE300)
15	19936	Base Seal (2510)
16	19322	2510 Adapter Base
17	19197	Slip Ring
18	18303	Tank O-Ring, 2510 Valve
19	13304	Distributor O-Ring, -121
20	13030	Distributor Retainer
26	10218	Micro Switch, Drive Motor
27	10909	Connecting Link Pin
28	10338	Roll Pin
29	12777	Brine Cam, STF
30	SCA-925	Environmental Cover
31	18312	Retainer Clip, Drain

# CKV-1 Coupling Check Valve Installation

The check valve included with this unit replaces the coupling on the **INLET** of a water treatment unit between the bypass valve and the valve body. In units designed to maintain an air head, this check valve will prevent the loss of air when water is used prior to the water treatment unit (outside hose bibs, heat pumps, lawn irrigation, etc.).

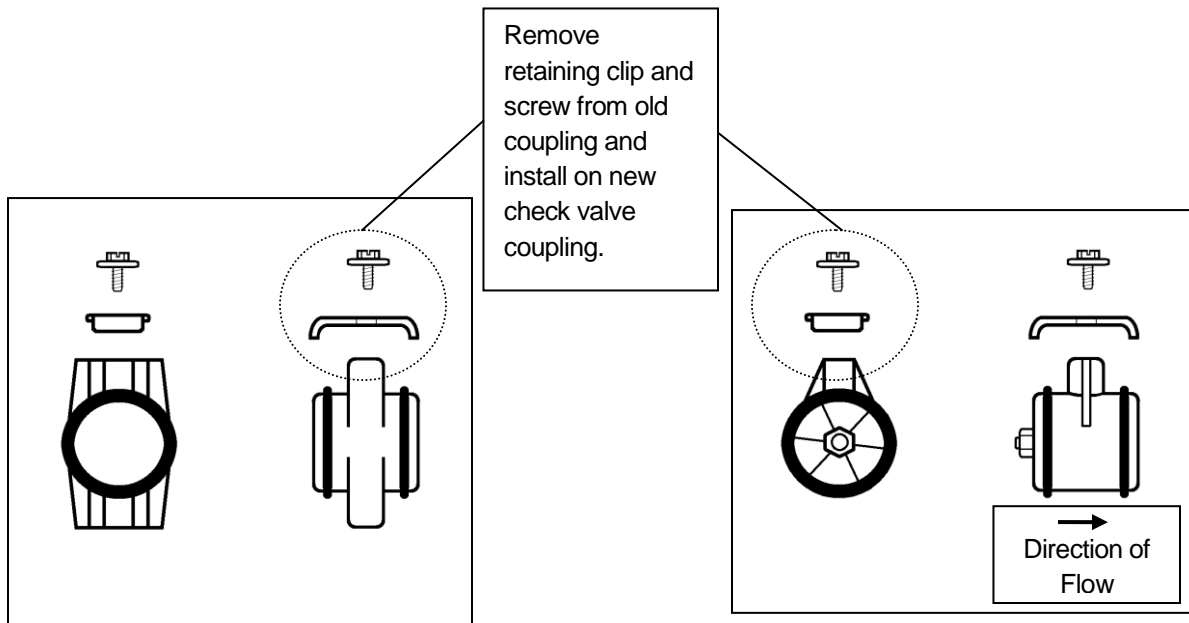
**WARNING:** Installation of this check valve will prevent hot water expansion in the plumbing. **An expansion tank must be used on the hot water line to allow for thermal expansion.** All local plumbing codes must be followed.

## INSTALLATION:

1. If the water treatment unit was previously installed, place it in bypass position and relieve the pressure from the tank. (Refer to water treatment unit manufacturer's instructions.)
2. Remove coupling from INLET of water treatment unit. Coupling will be located between control valve and bypass valve.
3. Remove retaining clip and screw from original coupling and install on check valve coupling.
4. Install the new check valve on the INLET of the water treatment unit.

**NOTE:** Pay close attention to the direction of flow arrow molded on the side of the check valve body

5. Reconnect bypass valve, turn on water and check for leaks. (Refer to manufacturer's instructions for detailed instructions on pressurizing the water treatment unit.)



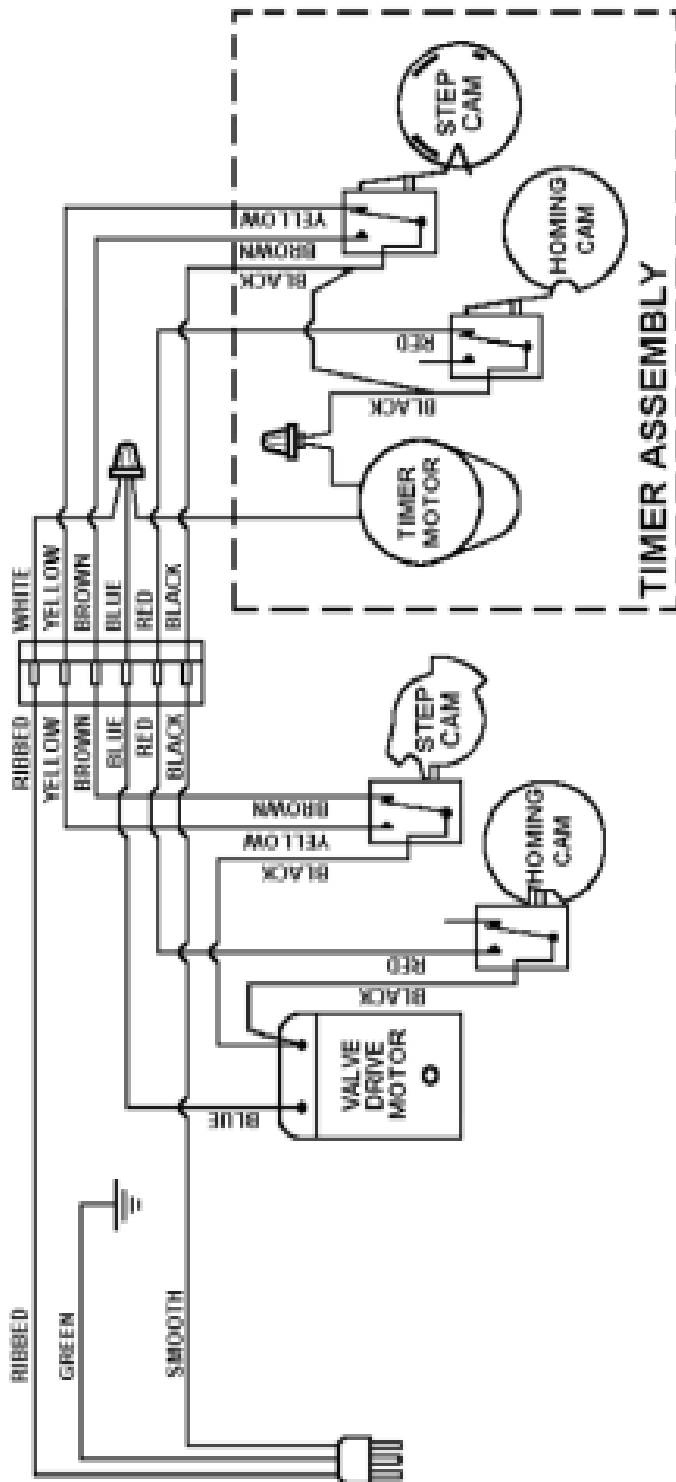
# Troubleshooting

PROBLEM	CAUSES	SOLUTIONS
Excessive pressure drop through filter	<ul style="list-style-type: none"> <li>A) Filter not backwashing</li> <li>B) Filter bed loaded with sand</li> <li>C) Insufficient backwash</li> <li>D) "Cementing" or "Channeling"</li> <li>E) Control Valve plugged with debris</li> </ul>	<ul style="list-style-type: none"> <li>1) Check timer motor and replace if faulty</li> <li>2) Ensure uninterrupted power supply</li> <li>3) Check Backwash frequency setup</li> <li>4) Verify sediment being removed is less dense than the filter media and install a "Spin-Down" type sediment filter ahead of the filter to remove well sand</li> <li>5) Increase frequency of backwash</li> <li>6) Increase length of backwash and rinse cycles</li> <li>7) Verify adequate pumping rate for backwash</li> <li>8) Probe media bed to check for "Cementing"</li> <li>9) Check drain line for restriction: frozen, plugged, kinked, exceeds 15', overhead installation, flexible drain line, drain line diameter too small</li> <li>10) Disassemble and clean control valve</li> </ul>
Water is red from the tap	<ul style="list-style-type: none"> <li>A) Leaking bypass valve</li> <li>B) Internal valve leak</li> <li>C) Distributor not seated properly in control valve</li> <li>D) Water usage flow rate exceeds filter specifications</li> <li>E) Insufficient backwash</li> </ul>	<ul style="list-style-type: none"> <li>1) Verify bypass valve is in service position and inspect seal, replace if needed</li> <li>2) Replace spacers and seals</li> <li>3) Verify distributor tube seated securely in control valve body</li> <li>4) Verify actual water usage flow rates against system specifications</li> <li>5) Verify adequate pumping rate for backwash</li> <li>6) Increase frequency of backwash</li> <li>7) Increase length of backwash and rinse cycles</li> </ul>
Clear water turns red after drawn	<ul style="list-style-type: none"> <li>A) Insufficient air draw</li> <li>B) Plugged injector or injector screen</li> <li>C) Open or leaking bypass valve</li> <li>D) pH too low</li> </ul>	<ul style="list-style-type: none"> <li>1) Verify air draw check valve is functioning properly and replace if needed</li> <li>2) Check drain line for restriction: frozen, plugged, kinked, exceeds 15', overhead installation, flexible drain line, drain line diameter too small</li> <li>3) Verify adequate pumping rate for backwash</li> <li>4) Increase air draw time</li> <li>5) Remove and clean injector &amp; screen</li> <li>6) Verify bypass valve is in service position and inspect seal, replace if needed</li> <li>7) Test pH. Must be 7.0 or higher or 8.2 or higher if Manganese is present (also see next troubleshooting section)</li> </ul>
IP05 or IP05M media fails to raise pH sufficiently	<ul style="list-style-type: none"> <li>A) Water usage flow rate is too high to provide adequate contact time</li> <li>B) Additional steps are needed to effectively raise pH</li> </ul>	<ul style="list-style-type: none"> <li>1) Verify actual water usage flow rates against system specifications</li> <li>2) Add MpH Adder to media tank</li> <li>3) Install a chemical feed pump system ahead of the filter with Soda Ash</li> </ul>

## Troubleshooting (cont.)

PROBLEM	CAUSES	SOLUTIONS
Howling or whistling noise during regeneration	A) Inadequate drain line diameter or drain line restricted	1) Reconfigure or replace drain line
Control Valve cycles continually	A) Faulty switch B) Faulty timer motor	1) Replace faulty switch 2) Replace faulty timer motor
Continuous flow of water to drain	A) Loss of electrical power during regeneration B) Program wheel setup incorrectly C) Debris in control valve D) Internal leak in control valve E) Drive motor faulty	1) Ensure electrical outlet is functioning 2) Verify timer programming 3) Disassemble and clean control valve 4) Replace seals and/or piston 5) Replace faulty drive motor
Media in the service lines	A) Unit installed backwards B) Damaged distributor basket C) Insufficient gravel under bed	1) Re-plumb the water lines so that the supply side of the line is connected to the inlet of the bypass and the service side is connected to the outlet. 2) Replace damaged distributor 3) Add gravel to filter tank

# 2P Control Valve Wiring



# TEN YEAR LIMITED WARRANTY

**WARRANTY – WATCO warrants this water conditioner against any defects that are due to faulty material or workmanship during the warranty period. This warranty does not include damage to the product resulting from accident, neglect, misuse, misapplication, alteration, installation or operation contrary to printed instructions, or damage caused by freezing, fire, flood, or Acts of God. From the original date of consumer purchase, we will repair or replace, at our discretion, any part found to be defective within the warranty period described below. Purchaser is responsible for any shipping cost to our facility and any local labor charges.**

- One year on the entire water conditioner
- Five years on the control valve
- Ten years on the mineral tank

**GENERAL CONDITIONS – Should a defect or malfunction occur, contact the dealer that you purchased the product from. If you are unable to contact the dealer, contact WATCO (see contact info below). We will require a full description of the problem, model number, date of purchase, and selling dealer’s business name and address.**

**We assume no warranty liability in connection with this water conditioner other than specified herein. This warranty is in lieu of all other warranties, expressed or implied, including warranties of fitness for a particular purpose. We do not authorize any person or representative to assume for us any other obligations on the sale of this water conditioner.**

### FILL IN AND KEEP FOR YOUR RECORDS

Original Purchaser	Date of Purchase	Model #	
Address of Original Installation		City	State
Dealer Purchased From	Dealer Address	City	State

6610 Guion Road, P.O. Box 681430, Indianapolis, IN 46268  
Ph: (317)290-2500 Toll Free: (800)873-1103 Fax: (317)290-2512