



RGF/RAF-210-336

Product Specifications

SINGLE PACKAGE ROOFTOP UNITS WITH X-VANE™ FAN TECHNOLOGY: GAS HEATING/ELECTRIC COOLING (RGF) AND ELECTRIC COOLING/OPTIONAL ELECTRIC HEAT (RAF) 17.5 TO 27.5 TON

The new 17.5 to 27.5 Ton RGF/RAF210-336 Series rooftops continue our legacy with R-454B, our low global warming potential refrigerant. With competitive efficiencies, X-Vane™ Fan Technology, locally available stock, and direct fit footprints, new installations and replacements are easier than ever.

New major design features include:

- Environmentally balanced R-454B refrigerant, which delivers a 75% reduction in global warming potential (GWP) compared to R-410A. R-454B's GWP of 466 easily exceeds the EPA (Environmental Protection Agency) requirement of <700 GWP.
- A patented, industry-first vane axial indoor fan system with an electronically commutated motor for simplicity and efficiency. When compared to traditional belt-driven forward curve fans, our reliable system has:
 - 75% fewer moving parts
 - Up to 40% greater efficiency
 - No fan belts, pulleys, shaft, or shaft bearings
 - Better sound and comfort due to slow ramp-up capability
 - Internal protection from phase reversal and phase loss situations
 - High external static capability
 - Slide-out blower assembly design
- Reliable and highly safety protected 2 stage cooling with tandem scroll compressor technology, fully active evaporator coil, and mixed air temperature protection on all models
- Unit control board (UCB) with intuitive indoor fan adjustment that uses simple dial and switch configuration
- Reliable copper tube/aluminum fin condenser coil with 5/16 in. tubing to help reduce refrigerant charge and weight versus prior designs

RGF/RAF units up to 27.5 tons are specifically designed to fit on existing roof curbs, which makes replacement easy and eliminates the need for curb adapters, changing utility connections or supporting curb overhang situations.

Two-speed indoor fan motor system helps deliver IEERs up to 14.7.

With “no-strip” screw collars, handled access panels, and more, the unit is easy to install, easy to maintain, and easy to use. Your new 17.5 to 27.5 ton RGF/RAF rooftop unit (RTU) provides optimum comfort and control from a packaged rooftop.

Installation ease

Lighter units make for easy replacement and aid in the structural approval process. Units have simple, fast plug-in connections to the standard integrated unit control board (UCB). Clearly labeled connections points to reduce installation time. Also, a large control box provides room to work.

Easy to maintain

With the X-Vane Fan vane axial fan system and a direct drive ECM motor, belts and pulleys are a thing of the past. This frees up maintenance, installation and commissioning time. Should an adjustment be necessary, it can easily be made via the UCB in the control box. For regular service activities, our easy-access handles provide a quick solution to all commonly accessed service panels, and our sloped, corrosion-resistant composite drain pan sheds water and will not rust. Service gauge connections are included on compressor suction/discharge lines and before and after the filter drier to monitor system operation during maintenance.



RGF/RAF210-336

X-Vane Fan™

Table of contents

	PAGE		PAGE
FEATURES/BENEFITS	3	FAN DATA	64
MODEL NUMBER NOMENCLATURE	4	ELECTRICAL DATA	89
CAPACITY RATINGS	6	TYPICAL WIRING DIAGRAMS	105
PHYSICAL DATA	9	SEQUENCE OF OPERATION	111
OPTIONS AND ACCESSORIES	12	APPLICATION DATA	113
BASE UNIT DIMENSIONS	17	GUIDE SPECIFICATIONS — RGF	115
ACCESSORY DIMENSIONS	47	GUIDE SPECIFICATIONS — RAF	125
PERFORMANCE DATA	50		

Easy to use

The newly re-designed unit control board puts all connections and troubleshooting points in one convenient place. Most low voltage connections use the same board and are easy to access. Setting up the fan is simple using an intuitive switch and rotary dial arrangement. Our rooftops have high and low pressure switches, a new mixed air temperature switch, a filter drier, and 2 in. filters standard.

R-454B Features

With a GWP of 466 and similar working pressure and performance to R-410A, R-454B easily exceeds the EPA's new, stringent <700 GWP refrigerant requirement while minimizing unit redesign. Like other next generation refrigerants (R-32, etc.), R-454B is classified as an "A2L" refrigerant by ASHRAE^{®1} (American Society of Heating, Refrigerating, and Air-Conditioning Engineers). This designation means that R-454B is "mildly flammable" under certain conditions. While this is a change from legacy "A1 — No Flame Propagation" refrigerants like R-410A, A2Ls are still very low on the flammability scale and quite safe for use. A2L refrigerants are difficult to ignite and have an extremely low flame speed — much less so than natural gas, propane, or even rubbing alcohol. We are committed to safety. As such, all of our R-454B rooftop units include a factory-installed dissipation control board and leak sensor designed to last the lifetime of the unit. This system is certified to UL 60335-2-40 and designed to work right away, without any field configuration or wiring. In the event of a leak, these systems automatically identify and resolve the issue by safely dissipating the refrigerant to ensure there is no risk to equipment, buildings, or occupants.

X-Vane™ Fan Technology

Direct drive X-Vane Fan Technology indoor fan system uses vane axial fan and electronically commutated motor. The benefit is clear: when compared to legacy belt drive systems, this vane axial design has 75% fewer moving parts, uses up to 40% less energy, and has no belts, blower bearings, or shaft. The full fan and motor assembly also slides out for easier maintenance and service.

1. Third-party trademarks and logos are the property of their respective owners.

Features/Benefits

Value-added features include:

- Optional Hot Gas Re-Heat dehumidification system for improved part load humidity performance
- Single point gas and electrical connections
- TXV refrigerant metering devices on 17.5 to 27.5 ton models
- Scroll compressors with internal line-break overload protection
- Easy-to-access tool-less filter door, filter tracks that tilt out for filter removal and replacement, and filter size consistency across units

Streamlined control and integration

Units are compatible with conventional thermostat controls.

Operating efficiency and flexibility

These RGF/RAF packaged rooftops meet the DOE 2023 efficiency standard, as well as ASHRAE (American Society of Heating, Refrigerating, and Air-Conditioning Engineers) 90.1 and IECC^{®1} (International Energy Conservation Code) requirements.

Comfort control

Our patented Hot Gas Re-Heat dehumidification system is an all-inclusive factory-installed option on gas heating/electric cooling and electric cooling/electric heat models. This system provides reliable, flexible operation to meet indoor part load sensible and latent requirements as well as multiple gas heat and electric heat sized to fit an array of applications.

Model number nomenclature

RGF210-336 Model Number Nomenclature

MODEL SERIES	R	G	F	2	1	0	L	D	2	A	0	A	A	A
Position Number	1	2	3	4	5	6	7	8	9	10	11	12	13	14
R = Rooftop														
G = Gas Heat/Electric Cooling	Type													
F = Standard Efficiency Packaged RTU with X-Vane™ Technology	Unit Efficiency													
210 = 210,000, 17.5 Ton 240 = 240,000, 20.0 Ton 300 = 300,000, 25.0 Ton 336 = 336,000, 27.5 Ton	Nominal Cooling Capacity													
H = 208/230-3-60 L = 460-3-60 S = 575-3-60	Voltage													
D = Low Gas Heat E = Medium Gas Heat F = High Gas Heat S = Low Gas Heat, SS (Stainless Steel) Heat Exchanger R = Medium Gas Heat, SS Heat Exchanger T = High Gas Heat, SS Heat Exchanger	Heating Capacity													
2 = Standard/Medium Static Fan, Vertical Supply 3 = High Static Fan, Vertical Supply 4 = High Static Fan, Vertical Supply with Hot Gas Re-Heat 5 = Standard/Medium Static Fan, Vertical Supply and Filter Status Switch 6 = High Static Fan, Vertical Supply and Filter Status Switch 7 = High Static Fan, Vertical Supply with Hot Gas Re-Heat and Filter Status Switch J = High Static Fan, Horizontal Supply L = High Static Fan, Horizontal Supply with Filter Status Switch M = High Static Fan, Horizontal Supply with Hot Gas Re-Heat N = High Static Fan, Horizontal Supply with Hot Gas Re-Heat and Filter Status Switch	Motor (Indoor Fan)													
A = None B = Temperature Economizer with Barometric Relief F = Enthalpy Economizer with Barometric Relief L = ULL (Ultra Low Leak) Temperature Economizer with Barometric Relief and CO ₂ Sensor M = ULL Enthalpy Economizer with Barometric Relief and CO ₂ Sensor N = ULL Temperature Economizer with Power Exhaust and CO ₂ Sensor, Vertical Only P = ULL Enthalpy Economizer with Power Exhaust and CO ₂ Sensor, Vertical Only U = ULL Temperature Economizer with Barometric Relief V = ULL Temperature Economizer with Power Exhaust, Vertical Only W = ULL Enthalpy Economizer with Barometric Relief X = ULL Enthalpy Economizer with Power Exhaust, Vertical Only	Outdoor Air Options / Control													
0A - None Note: See the RGF 17.5 to 27.5 Ton Specification Sheet for Factory Installed Options	Factory Installed Options¹													
A = Al/Cu - Al/Cu B = Precoat Al/Cu - Al/Cu C = E-coat Al/Cu - Al/Cu D = E-coat Al/Cu - E-coat Al/Cu M = Al/Cu - Al/Cu — Louvered Hail Guard N = Precoat Al/Cu - Al/Cu — Louvered Hail Guard P = E-coat Al/Cu - Al/Cu — Louvered Hail Guard Q = E-coat Al/Cu - E-coat Al/Cu — Louvered Hail Guard R = Cu/Cu - Al/Cu — Louvered Hail Guard S = Cu/Cu - Cu/Cu — Louvered Hail Guard	Condenser / Evaporator Coil Configuration													
A = Standard with Electromechanical Controls	Controls													

NOTE(S):

¹Combinations of factory-installed options are available, see Specifications Sheet for details.

Model number nomenclature (cont)

RAF210-336 Model Number Nomenclature

MODEL SERIES	R	A	F	2	1	0	L	0	2	A	0	A	A	A
Position Number	1	2	3	4	5	6	7	8	9	10	11	12	13	14
R = Rooftop														
A = Electric Cooling/Electric Heat	Type													
F = Standard Efficiency Packaged RTU with X-Vane™ Technology	Unit Efficiency													
210 = 210,000, 17.5 Ton 240 = 240,000, 20.0 Ton 300 = 300,000, 25.0 Ton 336 = 336,000, 27.5 Ton	Nominal Cooling Capacity													
H = 208/230-3-60 L = 460-3-60 S = 575-3-60	Voltage													
0 = No Heat	Heating Capacity													
2 = Standard/Medium Static Fan, Vertical Supply 3 = High Static Fan, Vertical Supply 4 = High Static Fan, Vertical Supply with Hot Gas Re-Heat 5 = Standard/Medium Static Fan, Vertical Supply and Filter Status Switch 6 = High Static Fan, Vertical Supply and Filter Status Switch 7 = High Static Fan, Vertical Supply with Hot Gas Re-Heat and Filter Status Switch J = High Static Fan, Horizontal Supply L = High Static Fan, Horizontal Supply with Filter Status Switch M = High Static Fan, Horizontal Supply with Hot Gas Re-Heat N = High Static Fan, Horizontal Supply with Hot Gas Re-Heat and Filter Status Switch	Motor (Indoor Fan)													
A = None B = Temperature Economizer with Barometric Relief F = Enthalpy Economizer with Barometric Relief L = ULL (Ultra Low Leak) Temperature Economizer with Barometric Relief and CO ₂ Sensor M = ULL Enthalpy Economizer with Barometric Relief and CO ₂ Sensor N = ULL Temperature Economizer with Power Exhaust and CO ₂ Sensor, Vertical Only P = ULL Enthalpy Economizer with Power Exhaust and CO ₂ Sensor, Vertical Only U = ULL Temperature Economizer with Barometric Relief V = ULL Temperature Economizer with Power Exhaust, Vertical Only W = ULL Enthalpy Economizer with Barometric Relief X = ULL Enthalpy Economizer with Power Exhaust, Vertical Only	Outdoor Air Options / Control													
0A - None Note: See the RAF 17.5 to 27.5 Ton Specification Sheet for Factory Installed Options	Factory Installed Options¹													
A = Al/Cu - Al/Cu B = Precoat Al/Cu - Al/Cu C = E-coat Al/Cu - Al/Cu D = E-coat Al/Cu - E-coat Al/Cu M = Al/Cu - Al/Cu — Louvered Hail Guard N = Precoat Al/Cu - Al/Cu — Louvered Hail Guard P = E-coat Al/Cu - Al/Cu — Louvered Hail Guard Q = E-coat Al/Cu - E-coat Al/Cu — Louvered Hail Guard R = Cu/Cu - Al/Cu — Louvered Hail Guard S = Cu/Cu - Cu/Cu — Louvered Hail Guard	Condenser / Evaporator Coil Configuration													
A = Standard with Electromechanical Controls	Controls													

NOTE(S):

¹Combinations of factory-installed options are available, see Specifications Sheet for details.

Capacity ratings

RGF AHRI Ratings^{a,b,c,d}

RGF UNIT	COOLING STAGES	NOMINAL CAPACITY (TONS)	NET COOLING CAPACITY (MBH)	TOTAL POWER (kW)	EER	IEER WITH 2-SPEED INDOOR FAN MOTOR	AHRI RATING CFM	AHRI PART LOAD CFM
RGF210	2	17.5	206.0	19.1	10.8	14.5	6,125	3,675
RGF240	2	20.0	248.0	24.8	10.0	14.5	7,000	4,200
RGF300	2	25.0	278.0	28.4	9.8	14.0	8,750	5,567
RGF336	2	27.5	314.0	32.0	9.8	14.0	10,000	6,000

NOTE(S):

- Rated in accordance with AHRI Standards 340/360.
- Rating are based on:
 - Cooling Standard:** 80°F (27°C) db, 67°F (19°C) wb indoor air temperature and 95°F (35°C) db outdoor air temperature.
 - IEER Standard:** A measure that expresses cooling part-load EER efficiency for commercial unitary air-conditioning and heat pump equipment on the basis of weighted operation at various load capacities.
- All RGF units comply with ASHRAE 90.1-2019 (American Society of Heating, Refrigerating, and Air-Conditioning Engineers) and DOE-2023 (Department of Energy) Energy Standard for minimum IEER requirements.
- RGF units comply with US Energy Policy Act (2005). To evaluate code compliance requirements, refer to state and local codes.

LEGEND

- AHRI** — Air-Conditioning, Heating and Refrigeration Institute
- EER** — Energy Efficiency Ratio
- IEER** — Integrated Energy Efficiency Ratio



RAF AHRI Ratings^{a,b,c,d}

RAF UNIT	COOLING STAGES	NOMINAL CAPACITY (TONS)	NET COOLING CAPACITY (MBH)	TOTAL POWER (kW)	EER	IEER WITH 2-SPEED INDOOR FAN MOTOR	AHRI RATING CFM	AHRI PART LOAD CFM
RAF210	2	17.5	206.0	18.7	11.0	14.7	6,125	3,675
RAF240	2	20.0	248.0	24.3	10.2	14.7	7,000	4,200
RAF300	2	25.0	278.0	27.8	10.0	14.2	8,750	5,567
RAF336	2	27.5	314.0	31.4	10.0	14.2	10,000	6,000

NOTE(S):

- Rated in accordance with AHRI Standards 340/360.
- Rating are based on:
 - Cooling Standard:** 80°F (27°C) db, 67°F (19°C) wb indoor air temperature and 95°F (35°C) db outdoor air temperature.
 - IEER Standard:** A measure that expresses cooling part-load EER efficiency for commercial unitary air-conditioning and heat pump equipment on the basis of weighted operation at various load capacities.
- All RAF units comply with ASHRAE 90.1-2019 (American Society of Heating, Refrigerating, and Air-Conditioning Engineers) and DOE-2023 (Department of Energy) Energy Standard for minimum IEER requirements.
- RAF units comply with US Energy Policy Act (2005). To evaluate code compliance requirements, refer to state and local codes.

LEGEND

- AHRI** — Air-Conditioning, Heating and Refrigeration Institute
- EER** — Energy Efficiency Ratio
- IEER** — Integrated Energy Efficiency Ratio



Capacity ratings (cont)

Sound Ratings Table^{a,b,c}

RGF/RAF UNIT	COOLING STAGES	OUTDOOR SOUND (dB) at 60 Hz								
		A-WEIGHTED	63	125	250	500	1000	2000	4000	8000
210	2	84.1	92.2	83.9	80.4	81.8	78.7	76.5	72.2	65.4
240	2	86.5	95.6	87.5	84.2	84.2	81.7	77.9	73.2	66.3
300	2	85.9	97.1	88.3	84.4	83.3	80.7	77.4	73.4	67.3
336	2	85.9	97.1	88.3	84.4	83.3	80.7	77.4	73.4	67.3

NOTE(S):

- Outdoor sound data is measured in accordance with AHRI.
- Measurements are expressed in terms of sound power. Do not compare these values to sound pressure values because sound pressure depends on specific environmental factors which normally do not match individual applications. Sound power values are independent of the environment and therefore more accurate.
- A-weighted sound ratings filter out very high and very low frequencies, to better approximate the response of "average" human ear. A-weighted measurements for RGF/RAF units are taken in accordance with AHRI.

LEGEND

dB — Decibel

Minimum - Maximum Airflow Ratings (cfm) — Natural Gas and Propane

UNIT	HEAT LEVEL	COOLING			HEATING ^a	
		MINIMUM 2-SPEED AIRFLOW (LOW SPEED)	MINIMUM 2-SPEED AIRFLOW (HIGH SPEED)	MAXIMUM AIRFLOW CFM	MINIMUM AIRFLOW CFM	MAXIMUM AIRFLOW CFM
RGF210	LOW	3,150	5,250	8,750	3,000	11,000
	MED				3,880	9,300
	HIGH				4,620	10,000
RGF240	LOW	3,600	6,000	10,000	3,000	11,000
	MED				3,880	11,630
	HIGH				4,620	10,000
RGF300	LOW	5,000	7,500	12,500	3,000	16,500
	MED				3,880	15,500
	HIGH				4,620	15,000
RFG336	LOW	4,950	8,250	13,750	3,000	16,500
	MED				3,880	15,500
	HIGH				4,620	15,000

NOTE(S):

- Heating rating values are identical for aluminum heat exchangers and stainless steel heat exchangers.

Minimum - Maximum Airflow Ratings (cfm) — Cooling Units and Accessory Electric Heat

UNIT	COOLING			ELECTRIC HEAT ^a	
	MINIMUM 2-SPEED AIRFLOW (LOW SPEED)	MINIMUM 2-SPEED AIRFLOW (HIGH SPEED)	MAXIMUM AIRFLOW CFM	MINIMUM AIRFLOW CFM	MAXIMUM AIRFLOW CFM
RAF210	3,150	5,250	8,750	5,250	8,750
RAF240	3,600	6,000	10,000	6,000	10,000
RAF300	5,000	7,500	12,500	7,500	12,500
RAF336	4,950	8,250	13,750	8,250	13,750

NOTE(S):

- Electric heat modules and single point kits are available as field-installed accessories for RAF units.

Capacity ratings (cont)

Heat Rating Table — Natural Gas and Propane

UNIT	GAS HEAT	AL/SS HEAT EXCHANGER		TEMPERATURE RISE (°F)	THERMAL EFFICIENCY (%)
		INPUT/OUTPUT STAGE 1 (MBH)	INPUT/OUTPUT STAGE 2 (MBH)		
RGF210	LOW	176 / 142	220 / 178	15-45	81
	MED	248 / 200	310 / 251	25-55	81
	HIGH	320 / 260	400 / 324	30-60	81
RGF240	LOW	176 / 142	220 / 178	15-45	81
	MED	248 / 200	310 / 251	20-55	81
	HIGH	320 / 260	400 / 324	30-60	81
RGF300	LOW	176 / 142	220 / 178	10-45	81
	MED	248 / 200	310 / 251	15-55	81
	HIGH	320 / 260	400 / 324	20-60	81
RGF336	LOW	176 / 142	220 / 178	10-45	81
	MED	248 / 200	310 / 251	15-55	81
	HIGH	320 / 260	400 / 324	20-60	81

LEGEND

MBH — Btuh in thousands

Physical data

RGF/RAF 210 to 240 Physical Data

RGF/RAF UNIT	RGF210**2/3/5/6/J/L	RGF210**4/7/M/N	RGF240**2/3/5/6/J/L	RGF240**4/7/M/N
NOMINAL TONS	17.5	17.5	20.0	20.0
BASE UNIT OPERATING WT (lb) RGF/RAF^a	1800/1673	1800/1673	2000/1873	2000/1873
REFRIGERATION SYSTEM				
No. Circuits/No. Compressors/Type	1/2/Scroll	1/2/Scroll	1/2/Scroll	1/2/Scroll
R-454B Charge (lb-oz)	23-3	—	28-10	—
Hot Gas Re-Heat R-454B Charge (lb-oz)	—	32-2	—	38-6
Metering Device	TXV	—	TXV	—
Hot Gas Re-Heat Metering Device	—	TXV	—	TXV
High-Pressure Trip/Reset (psig)	660/505	660/505	660/505	660/505
Low-Pressure Trip/Reset	54/117	54/117	54/117	54/117
EVAPORATOR COIL				
Material (Tube/Fin)	Cu/Al	Cu/Al	Cu/Al	Cu/Al
Coil Type	3/8 in. RTPF	3/8 in. RTPF	3/8 in. RTPF	3/8 in. RTPF
Rows/FPI	4/15	4/15	4/15	4/15
Total Face Area (ft²)	22	22	22	22
Condensate Drain Connection Size	3/4 in.	3/4 in.	3/4 in.	3/4 in.
CONDENSER COIL				
Material (Tube/Fin)	Cu/Al	Cu/Al	Cu/Al	Cu/Al
Coil Type	5/16 in. RTPF	5/16 in. RTPF	5/16 in. RTPF	5/16 in. RTPF
Rows/FPI	2/18	2/18	2/18	2/18
Total Face Area (ft²)	39.1	39.1	47.7	47.7
HOT GAS RE-HEAT COIL				
Material	—	Cu/Al	—	Cu/Al
Coil Type	—	5/16 in. RTPF	—	5/16 in. RTPF
Rows/FPI	—	1/18	—	1/18
Total Face Area (ft²)	—	21.4	—	21.4
EVAPORATOR FAN AND MOTOR				
Vertical Standard Static 3 Phase				
Motor Qty / Drive Type	2 / Direct	2 / Direct	2 / Direct	2 / Direct
Maximum Cont bhp (per motor)	2.4	2.4	2.4	2.4
Range (rpm)	250-2000	250-2000	250-2000	250-2000
Fan Qty / Type	2 / Vane Axial	2 / Vane Axial	2 / Vane Axial	2 / Vane Axial
Fan Diameter (in.)	22	22	22	22
Vertical High Static 3 Phase				
Motor Qty / Drive Type	2 / Direct	2 / Direct	2 / Direct	2 / Direct
Maximum Cont bhp (per motor)	3	3	5	5
Range (rpm)	250-2200	250-2200	250-2200	250-2200
Fan Qty / Type	2 / Vane Axial	2 / Vane Axial	2 / Vane Axial	2 / Vane Axial
Fan Diameter (in.)	22	22	22	22
Horizontal High Static 3 Phase				
Motor Qty / Drive Type	2 / Direct	2 / Direct	2 / Direct	2 / Direct
Maximum Cont bhp (per motor)	5	5	5	5
Range (rpm)	250-2200	250-2200	250-2200	250-2200
Fan Qty / Type	2 / Vane Axial	2 / Vane Axial	2 / Vane Axial	2 / Vane Axial
Fan Diameter (in.)	22	22	22	22
CONDENSER FAN AND MOTOR				
Qty / Motor Drive Type	3 / Direct	3 / Direct	4 / Direct	4 / Direct
Motor hp / rpm	1/4 / 1100	1/4 / 1100	1/4 / 1100	1/4 / 1100
Fan Diameter (in.)	22	22	22	22
FILTERS				
RA Filter Qty / Size (in.)	6 / 20x25x2	6 / 20x25x2	6 / 20x25x2	6 / 20x25x2
OA Inlet Screen Qty / Size (in.)	4 / 16x25x1	4 / 16x25x1	4 / 16x25x1	4 / 16x25x1

NOTE(S):

a. Base unit operating weight does not include weight of options.

LEGEND

bhp — Brake Horsepower
FPI — Fins Per Inch
OA — Outdoor Air
RA — Return Air

Physical data (cont)

RGF/RAF 300 to 336 Physical Data

RGF/RAF UNIT	RGF300**2/3/5/6/J/L	RGF300**4/7/M/N	RGF336**2/3/5/6/J/L	RGF336**4/7/M/N
NOMINAL TONS	25.0	25.0	27.5	27.5
BASE UNIT OPERATING WT (lb) RGF/RAF ^a	2174/2047	2174/2047	2351/2224	2351/2224
REFRIGERATION SYSTEM				
No. Circuits/No. Compressors/Type	1/2/Scroll	1/2/Scroll	1/2/Scroll	1/2/Scroll
R-454B Charge (lb-oz)	29-8	—	38-0	—
Hot Gas Re-Heat R-454B Charge (lb-oz)	—	39-5	—	45-10
Metering Device	TXV	—	TXV	—
Hot Gas Re-Heat Metering Device	—	TXV	—	TXV
High-Pressure Trip/Reset (psig)	660/505	660/505	660/505	660/505
Low-Pressure Trip/Reset	54/117	54/117	54/117	54/117
EVAPORATOR COIL				
Material (Tube/Fin)	Cu/Al	Cu/Al	Cu/Al	Cu/Al
Coil Type	3/8 in. RTPF	3/8 in. RTPF	3/8 in. RTPF	3/8 in. RTPF
Rows/FPI	4/17	4/17	4/17	4/17
Total Face Area (ft ²)	23.1	23.1	26	26
Condensate Drain Connection Size	3/4 in.	3/4 in.	3/4 in.	3/4 in.
CONDENSER COIL				
Material (Tube/Fin)	Cu/Al	Cu/Al	Cu/Al	Cu/Al
Coil Type	5/16 in. RTPF	5/16 in. RTPF	5/16 in. RTPF	5/16 in. RTPF
Rows/FPI	2/18	2/18	2/18	2/18
Total Face Area (ft ²)	52.7	52.7	59.9	59.9
HOT GAS RE-HEAT COIL				
Material	—	Cu/Al	—	Cu/Al
Coil Type	—	5/16 in. RTPF	—	5/16 in. RTPF
Rows/FPI	—	1/18	—	1/18
Total Face Area (ft ²)	—	22.4	—	25.3
EVAPORATOR FAN AND MOTOR				
Vertical Standard Static 3 Phase				
Motor Qty / Drive Type	2 / Direct	2 / Direct	2 / Direct	2 / Direct
Maximum Cont bhp (per motor)	3	3	3	3
Range (rpm)	250-2200	250-2200	250-2200	250-2200
Fan Qty / Type	2 / Vane Axial	2 / Vane Axial	2 / Vane Axial	2 / Vane Axial
Fan Diameter (in.)	22	22	22	22
Vertical High Static 3 Phase				
Motor Qty / Drive Type	2 / Direct	2 / Direct	2 / Direct	2 / Direct
Maximum Cont bhp (per motor)	5	5	5	5
Range (rpm)	250-2200	250-2200	250-2200	250-2200
Fan Qty / Type	2 / Vane Axial	2 / Vane Axial	2 / Vane Axial	2 / Vane Axial
Fan Diameter (in.)	22	22	22	22
Horizontal High Static 3 Phase				
Motor Qty / Drive Type	2 / Direct	2 / Direct	2 / Direct	2 / Direct
Maximum Cont bhp (per motor)	5	5	5	5
Range (rpm)	250-2200	250-2200	250-2200	250-2200
Fan Qty / Type	2 / Vane Axial	2 / Vane Axial	2 / Vane Axial	2 / Vane Axial
Fan Diameter (in.)	22	22	22	22
CONDENSER FAN AND MOTOR				
Qty / Motor Drive Type	4 / Direct	4 / Direct	6 / Direct	6 / Direct
Motor hp / rpm	1/4 / 1100	1/4 / 1100	1/4 / 1100	1/4 / 1100
Fan Diameter (in.)	22	22	22	22
FILTERS				
RA Filter Qty / Size (in.)	9 / 16x25x2	9 / 16x25x2	9 / 16x25x2	9 / 16x25x2
OA Inlet Screen Qty / Size (in.)	4 / 16x25x1	4 / 16x25x1	4 / 16x25x1	4 / 16x25x1

NOTE(S):

a. Base unit operating weight does not include weight of options.

LEGEND

bhp — Brake Horsepower
 FPI — Fins Per Inch
 OA — Outdoor Air
 RA — Return Air

Physical data (cont)

RGF 210 to 336 Gas Heat Data

RGF UNIT	RGF210	RGF240	RGF300	RGF336
NOMINAL TONS	17.5	20.0	25.0	27.5
GAS CONNECTION				
No. of Gas Valves	1	1	1	1
Natural Gas Supply Line Pressure (in. wg)/(psig)	5-13 / 0.18-0.47	5-13 / 0.18-0.47	5-13 / 0.18-0.47	5-13 / 0.18-0.47
Liquid Propane Supply Line Pressure (in. wg)/(psig)	11-13 / 0.40-0.47	11-13 / 0.40-0.47	11-13 / 0.40-0.47	11-13 / 0.40-0.47
HEAT ANTICIPATOR SETTING (AMPS)				
First Stage	0.14	0.14	0.14	0.14
Second Stage	0.14	0.14	0.14	0.14
NATURAL GAS HEAT				
LOW				
No. of Stages / No. of Burners (total)	2 / 5	2 / 5	2 / 5	2 / 5
Connection Size	3/4 in. NPT	3/4 in. NPT	3/4 in. NPT	3/4 in. NPT
Rollout Switch Opens / Closes (°F)	195 / 115	195 / 115	195 / 115	195 / 115
Temperature Rise (°F)	15-45	15-45	10-45	10-45
MEDIUM				
No. of Stages / No. of Burners (total)	2 / 7	2 / 7	2 / 7	2 / 7
Connection Size	3/4 in. NPT	3/4 in. NPT	3/4 in. NPT	3/4 in. NPT
Rollout Switch Opens / Closes (°F)	195 / 115	195 / 115	195 / 115	195 / 115
Temperature Rise (°F)	25-55	20-55	15-55	15-55
HIGH				
No. of Stages / No. of Burners (total)	2 / 9	2 / 9	2 / 9	2 / 9
Connection Size	3/4 in. NPT	3/4 in. NPT	3/4 in. NPT	3/4 in. NPT
Rollout Switch Opens / Closes (°F)	195 / 115	195 / 115	195 / 115	195 / 115
Temperature Rise (°F)	30-60	30-60	20-60	20-60
LIQUID PROPANE HEAT				
LOW				
No. of Stages / No. of Burners (total)	2 / 5	2 / 5	2 / 5	2 / 5
Connection Size	3/4 in. NPT	3/4 in. NPT	3/4 in. NPT	3/4 in. NPT
Rollout Switch Opens / Closes (°F)	195 / 115	195 / 115	195 / 115	195 / 115
Temperature Rise (°F)	15-45	15-45	10-45	10-45
MEDIUM				
No. of Stages / No. of Burners (total)	2 / 7	2 / 7	2 / 7	2 / 7
Connection Size	3/4 in. NPT	3/4 in. NPT	3/4 in. NPT	3/4 in. NPT
Rollout Switch Opens / Closes (°F)	195 / 115	195 / 115	195 / 115	195 / 115
Temperature Rise (°F)	25-55	20-55	15-55	15-55
HIGH				
No. of Stages / No. of Burners (total)	2 / 9	2 / 9	2 / 9	2 / 9
Connection Size	3/4 in. NPT	3/4 in. NPT	3/4 in. NPT	3/4 in. NPT
Rollout Switch Opens / Closes (°F)	195 / 115	195 / 115	195 / 115	195 / 115
Temperature Rise (°F)	30-60	30-60	20-60	20-60

Options and accessories

ITEM	FACTORY-INSTALLED OPTION	FIELD-INSTALLED ACCESSORY
GAS HEAT (RGF units only)		
Low, Medium or High Gas Heat — Aluminized Heat Exchanger	X	
Low, Medium or High Gas Heat — Stainless Steel Heat Exchanger	X	
Propane Conversion Kit		X
High Altitude Conversion Kit		X
Flue Discharge Deflector		X
ELECTRIC HEAT (RAF units only)		
Electric Resistance Heaters		X
Single Point Kits		X
CABINET		
Hinged Access Panels	X	
4 in. Filter Rack (filters not included)		X
COIL OPTIONS		
Cu/Cu Indoor and/or Outdoor Coils ^a	X	
Pre-Coated Outdoor Coils	X	
Premium, E-Coated Outdoor Coils	X	
HUMIDITY CONTROL		
Hot Gas Re-Heat Dehumidification System	X	
CONDENSER PROTECTION		
Condenser Coil Hail Guard (louvered design)	X	X
CONTROLS		
Thermostats, Temperature Sensors, and Subbases		X
Smoke Detector (supply and/or return air)	X	X
Horn Strobe Annunciator ^b		X
Time Guard II Compressor Delay Control Circuit		X
Phase Monitor		X
ECONOMIZERS AND OUTDOOR AIR DAMPERS		
EconomizerONE for Electromechanical Controls, complies with FDD (Standard and Ultra Low Leak damper models) ^c	X	X
Wi-Fi Stick for EconomizerONE (optional)		X
Motorized Two-Position Outdoor-Air Damper		X
Manual Outdoor-Air Damper (25% and 50%)		X
Barometric Relief ^d	X	X
Power Exhaust — centrifugal design	X	X
Condensate Overflow Switch	X	X

ITEM	FACTORY-INSTALLED OPTION	FIELD-INSTALLED ACCESSORY
ECONOMIZER SENSORS AND IAQ DEVICES		
Single Dry Bulb Temperature Sensors ^e	X	X
Differential Dry Bulb Temperature Sensors ^e		X
Differential Enthalpy Sensors ^e		X
CO ₂ Sensor (wall, duct, or unit mounted) ^e	X	X
INDOOR MOTOR AND DRIVE		
Multiple Motor and Drive Packages	X	
Fan Filter Status Switch	X	X
LOW AMBIENT CONTROLS		
Winter Start Kit ^f		X
Low Ambient Controller to 0°F (-18°C) ^f		X
POWER OPTIONS		
Convenience Outlet (powered)	X	
Convenience Outlet (unpowered)	X	
Convenience Outlet, 20 amp (unpowered)		X
Non-Fused Disconnect ^g	X	
High SCCR Protection ^h	X	
ROOF CURBS		
Roof Curb 14 in. (356 mm)		X
Roof Curb 24 in. (610 mm)		X

NOTE(S):

- a. Cu/Cu coils are only available with louvered hail guards.
- b. Requires a field-supplied 24V transformer for each application.
- c. FDD (Fault Detection and Diagnostic) capability per California Title 24 section 120.2.
- d. Included with economizer.
- e. Sensors used to optimize economizer performance.
- f. See application data for assistance.
- g. Non-fused disconnect switch cannot be used when unit FLA electrical rating exceeds:
 - 208V/230V = 200 amps
 - 460V/575V = 100 amps
- h. High SCCR rating is:
 - 208V/230V = 60 kA
 - 460V = 65 kA
 High SCCR (Short Circuit Current Rating) is not available on the following: units with Hot Gas Re-Heat system, Low Ambient controls, Phase loss monitor, Non-fused disconnect, Powered convenience outlet, or 575V models

Options and accessories (cont)

Factory-installed options

Economizer (dry-bulb or enthalpy)

Economizers save money. They bring in fresh, outside air for ventilation; and provide cool, outside air to cool your building. This is the preferred method of low-ambient cooling. When coupled to CO₂ sensors, economizers can provide even more savings by coupling the ventilation air to only that amount required.

Economizers are available, installed and tested by the factory, with either enthalpy or dry-bulb temperature inputs. Additional sensors are available as accessories to optimize the economizers. Economizers include barometric relief system to help equalize building pressures.

Economizers can be factory-installed or easily field-installed.

Unit mounted CO₂ sensor

The CO₂ sensor works with the economizer to intake only the correct amount of outside air for ventilation. As occupants fill your building, the CO₂ sensor detects their presence through increasing CO₂ levels, and opens the economizer appropriately. When the occupants leave, the CO₂ levels decrease, and the sensor appropriately closes the economizer. This intelligent control of the ventilation air, called demand controlled ventilation (DCV), reduces the overall load on the rooftop, saving money. It is also available as a field-installed accessory.

Smoke detector (supply and/or return air)

Smoke detectors make your application safer and your job easier. Smoke detectors immediately shut down the rooftop unit when smoke is detected. They are available, installed by the factory, for supply air, return air, or both.

Optional Hot Gas Re-Heat dehumidification system

Our Hot Gas Re-Heat dehumidification system is an all-inclusive factory-installed option that can be ordered with any RGF/RAF210-336 rooftop unit.

This system expands the envelope of operation of our rooftop products to provide unprecedented flexibility to meet year round comfort conditions.

The Hot Gas Re-Heat dehumidification system has a unique dual operational mode setting. The Hot Gas Re-Heat system provides greater dehumidification of the occupied space by 2 modes of dehumidification operations in addition to its normal design cooling mode.

The RGF/RAF210-336 rooftop coupled with the Hot Gas Re-Heat system is capable of operating in normal design cooling mode, sub-cooling mode, and hot gas reheat mode. Normal design cooling mode is when the unit will operate under its normal sequence of operation by cycling compressors to maintain comfort conditions.

Sub-cooling mode will operate to satisfy part load type conditions when the space requires combined sensible and a higher proportion of latent load control. Hot Gas Reheat mode will operate when outdoor temperatures diminish and the need for latent capacity is required for sole

humidity control Hot Gas Reheat mode will provide neutral air for maximum dehumidification operation.

NOTE: The Hot Gas Re-Heat system includes Low Ambient controller.

Hinged access panels

Allows access to unit's major components with specifically designed hinged access panels. Panels are filter, control box access indoor fan motor access.

Cu/Cu (indoor) coils

Copper fins and copper tubes are mechanically bonded to copper tubes and copper tube sheets. A polymer strip prevents coil assembly from contacting the sheet metal coil pan to minimize the potential for galvanic corrosion between coil and pan. Only available with louvered hail guards.

E-coated (outdoor and indoor) coils

These coils feature a flexible epoxy polymer coating uniformly applied to all coil surface areas without material bridging between fins. The coating process ensures complete coil encapsulation of tubes, fins, and headers.

Pre-coated outdoor coils

These coils feature a durable epoxy-phenolic coating that provides protection in mildly corrosive coastal environments. The coating minimizes galvanic action between dissimilar metals. The coating is applied to the aluminum fin stock prior to the fin stamping process to create an inert barrier between the aluminum fin and copper tube.

Condenser coil hail guard

These sleek, louvered panels protect the condenser coil from hail damage, foreign objects, and incidental contact. This can be purchased as a factory-installed option or as a field-installed accessory.

Stainless steel heat exchanger (RGF units only)

For this option, the tubular heat exchanger is made out of a minimum 20 gauge type 409 stainless steel for applications where the mixed air going to the heat exchanger is expected to drop below 45°F (7°C). Stainless steel may be specified on applications where the presence of airborne contaminants require its use (applications such as paper mills) or in areas with very high outdoor humidity that may result in severe condensation in the heat exchanger during cooling operation.

Convenience outlet (powered or un-powered)

Reduce service and/or installation costs by including a convenience outlet in your specification. We will install this service feature at our factory. Provides a convenient, 15 amp, 115v GFCI receptacle with "Wet in Use" cover. The "powered" option allows the installer to power the outlet from the line side of the disconnect or load side as required by code. The "unpowered" option is to be powered from a separate 115/120v power source.

The unpowered convenience outlet is available as a 15 amp factory-installed option or a 20 amp field-installed accessory.

Options and accessories (cont)

Non-fused disconnect

This OSHA-compliant, factory-installed, safety switch allows a service technician to locally secure power to the rooftop. When selecting a factory-installed non-fused disconnect, note they are sized for the unit as ordered from the factory. The sizing of these do not accommodate field-installed items such as power exhaust devices, etc. If field installing electric heat with factory-installed non-fused disconnect switch, a single point kit may or may not be required.

Condensate overflow switch

This sensor and related controller monitors the condensate level in the drain pan and shuts down compression operation when overflow conditions occur. It includes:

- Indicator light — solid red (more than 10 seconds on water contact — compressors disabled), blinking red (sensor disconnected)
- 10-second delay to break — eliminates nuisance trips from splashing or waves in pan (sensor needs 10 seconds of constant water contact before tripping)
- Disables the compressors operation when condensate plug is detected, but still allows fans to run for economizer.

Power exhaust with barometric relief

Superior internal building pressure control. This field-installed accessory may eliminate the need for costly, external pressure control fans. Included with factory-installed vertical economizers.

High Short Circuit Current Rating (SCCR) protection

This factory-installed option provides high short circuit current protection to each compressor, plus all indoor and outdoor fan motors of 60 kA (for 208/230-3-60 units) and 65 kA (for 460-3-60 units) against high potential fault current situations.

Standard unit comes with 5 kA rating.

This option is not available with factory installed Non-Fused Disconnect, Hot Gas Re-Heat system, Low Ambient controls, Phase loss monitor/protection, Powered convenience outlet, and 575 Volt models.

Field-installed accessories

Filter maintenance indicator

When the optional factory-installed filter maintenance indicator is used, a factory-installed differential pressure switch measures pressure drop across the outside air filter and activates a field-supplied dry contact indicator when the pressure differential exceeds the adjustable switch setpoint.

Condenser coil hail guard

Sleek, louvered panels protect the condenser coil from hail damage, foreign objects, and incidental contact. This can be purchased as a factory-installed option or as a field-installed accessory.

Differential enthalpy sensor

The differential enthalpy sensor is comprised of an outdoor and return air enthalpy sensors to provide differential enthalpy control. The sensor allows the unit to determine if outside air is suitable for free cooling.

Wall or duct mounted CO₂ sensor

The IAQ sensor shall be available in duct or wall mount. The sensor provides demand ventilation indoor air quality (IAQ) control.

Propane conversion kit (RGF units only)

Convert your gas heat rooftop from standard natural gas operation to Propane using this field-installed kit.

High altitude conversion kit (RGF units only)

High altitudes have less oxygen, which affects the fuel/air mixture in heat exchangers. In order to maintain a proper fuel/air mixture, heat exchangers operating in altitudes above 2000 ft (610 m) require different orifices. To select the correct burner orifices or determine the heat capacity for a high altitude application, use either the selection software, or the unit's service manual. High altitudes have less oxygen, which means heat exchangers need less fuel. The new gas orifices in this field-installed kit make the necessary adjustment for high altitude applications. They restore the optimal fuel to air mixture and maintain healthy combustion on altitudes above 2000 ft (610 m).

NOTE: Typical natural gas heating value ranges from 975 to 1050 Btu/ft³ at sea level nationally. The heating value goes down approximately 1.7% per every thousand feet elevation. Standard factory orifices can typically be used up to 2000 ft (610 m) elevation without any operational issues.

Flue discharge deflector (RGF units only)

The flue discharge deflector is a useful accessory when flue gas recirculation is a concern. By venting the flue discharge upwards, the deflector minimizes the chance for a neighboring unit to intake the flue exhaust.

4 in. filter rack kit

The 4 in. filter rack accessory kit is designed to hold 4 in. MERV-8 or MERV-13 filters. Filters not included in kit.

Phase monitor protection

The Phase Monitor Control will monitor the sequence of 3-phase electrical system to provide a phase reversal protection; and monitor the 3-phase voltage inputs to provide a phase loss protection for the 3-phase device. It will work on either a Delta or Wye power connection.

Winter start kit

The winter start kit extends the low ambient limit of your rooftop to 25°F (−4°C). The kit bypasses the low pressure switch, preventing nuisance tripping of the low pressure switch. Other low ambient precautions may still be prudent.

Low ambient controller

The low ambient controller is a head pressure controller kit that is designed to maintain the unit's condenser head pressure during periods of low ambient cooling operation. This device should be used as an alternative to economizer free

Options and accessories (cont)

cooling when economizer usage is either not appropriate or desired. The low ambient controller will either cycle the outdoor fan motors or operate them at reduced speed to maintain the unit operation, depending on the model. This controller allows cooling operation down to 0°F (-18°C) ambient conditions.

Roof curb (14 in./356 mm or 24 in./610 mm)

Full perimeter roof curb with exhaust capability provides separate air streams for energy recovery from the exhaust air without supply air contamination.

Filter status indicator accessory

Monitors static pressure across supply and exhaust filters and provides indication when filters become clogged.

Power exhaust

Superior internal building pressure control. This field-installed accessory may eliminate the need for costly, external pressure control fans.

Manual OA damper

Manual outdoor air dampers are an economical way to bring in ventilation air. The dampers are available in 25% and 50% versions.

Motorized Two-Position damper

The two-position, motorized outdoor air damper admits up to 100% outside air. Using reliable, gear-driven technology, the two-position damper opens to allow ventilation air and closes when the rooftop stops, stopping unwanted infiltration.

Electric heaters (RAF units only)

We offer a full-line of field-installed accessory heaters. The heaters are very easy to use, install and are all pre-engineered and certified.

Time Guard II control circuit

This accessory protects your compressor by preventing short-cycling in the event of some other failure, prevents the compressor from restarting for 30 seconds after stopping.

Wi-Fi Stick for EconomizerONE (optional)

The accessory Wi-Fi/WLAN stick can be connected to the EconomizerONE POL224 economizer controller via the USB host interface. The Wi-Fi stick enables a wireless connection to be made between a smartphone and the economizer controller via the Climatix™¹ mobile application for commissioning, troubleshooting, and maintenance operations. The Wi-Fi stick is required to utilize the mobile application but is not required for EconomizerONE setup and commissioning.

Climatix™ mobile application

The Climatix™ mobile application offers a best-in-class user interface and a simple step-by-step commissioning workflow using a mobile device. The user interface walks users through the setup of the controller and allows users to view the operating mode and parameters. Users can adjust setpoints, initiate damper tests, and save the final configuration as a favorite to expedite setup in the future.

The application is available on Android™¹ and Apple iOS®¹ platforms. The Wi-Fi stick for the EconomizerONE is required to join the Siemens-WiFi-Stick network and setup the controller on a smartphone.

NOTE: The Climatix app is not required to commission the EconomizerONE controller. The unit can be set up using the controller's on board button system.

1. Third-party trademarks and logos are the property of their respective owners.

Options and accessories (cont)

Options and Accessory Weights^a

OPTION / ACCESSORY NAME	RGF/RAF UNIT WEIGHT							
	210		240		300		336	
	lb	kg	lb	kg	lb	kg	lb	kg
Hot Gas Re-Heat System ^b	82	37	82	37	82	37	90	41
Power Exhaust	198	90	198	90	198	90	198	90
EconomizerONE	245	111	245	111	245	111	245	111
High Gas Heat (RGF units only)	127	58	127	58	127	58	127	58
Hail Guard (louvered)	90	41	90	41	100	46	100	46
Cu/Cu Condenser Coil	166	76	203	92	244	111	278	126
Cu/Cu Evaporator Coil	128	58	128	58	163	74	163	74
Roof Curb (14 in. curb)	240	109	255	116	255	116	255	116
Roof Curb (24 in. curb)	340	154	355	161	355	161	355	161
CO ₂ Sensor	5	3	5	3	5	3	5	3
Flue Discharge Deflector	7	3	7	3	7	3	7	3
Optional Indoor Motor ^c	30	14	30	14	0	0	0	0
Low Ambient Controller	9	4	9	4	9	4	9	4
Winter Start Kit	5	2	5	2	5	2	5	2
Return Air Smoke Detector	7	3	7	3	7	3	7	3
Supply Air Smoke Detector	7	3	7	3	7	3	7	3
Fan Filter Switch	2	1	2	1	2	1	2	1
Non-Fused Disconnect	15	7	15	7	15	7	15	7
Powered Convenience Outlet ^d	36	16	36	16	36	16	36	16
Unpowered Convenience Outlet	4	2	4	2	4	2	4	2
Enthalpy Sensor	2	1	2	1	2	1	2	1
Differential Enthalpy Sensor	3	1	3	1	3	1	3	1

NOTE(S):

- a. Where multiple variations are available, the heaviest combination is listed.
- b. For Hot Gas Re-Heat system, add Low Ambient controller weight.
- c. Add the Optional Indoor Motor weight to the weight of the base unit.
- d. Weight includes convenience outlet and convenience outlet transformer.

RGF210 Base Unit Dimensions



THIS DOCUMENT IS THE PROPERTY OF CARRIER CORPORATION AND IS DELIVERED UPON THE EXPRESS CONDITION THAT THE CONTENTS WILL NOT BE DISCLOSED OR USED WITHOUT WRITTEN CONSENT.

SUBMISSION OF THESE DRAWINGS OR DOCUMENTS DOES NOT CONSTITUTE PART PERFORMANCE OR ACCEPTANCE OF CONTRACT.

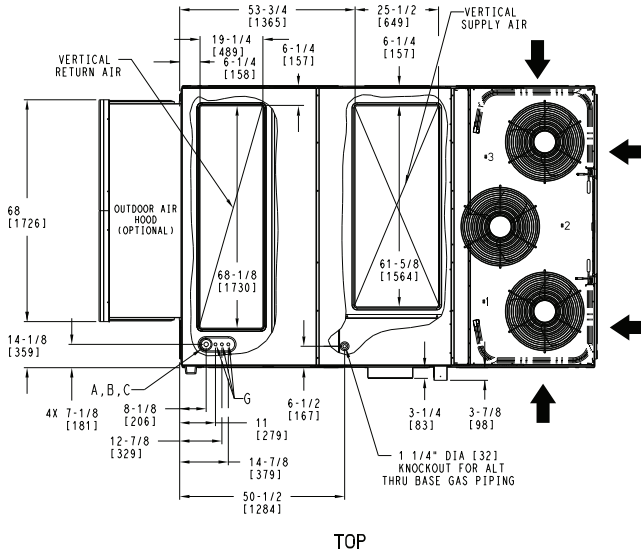
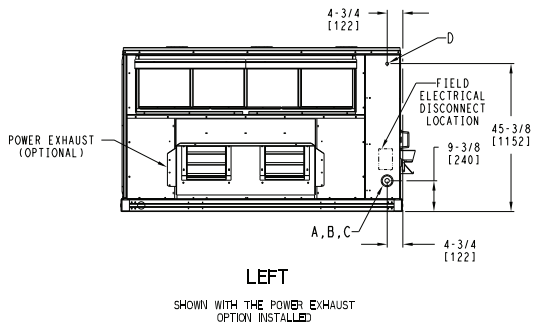
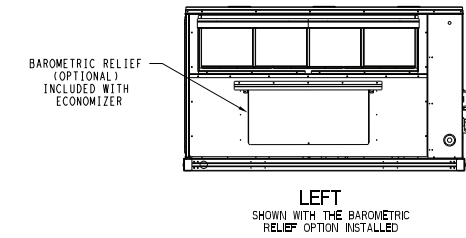
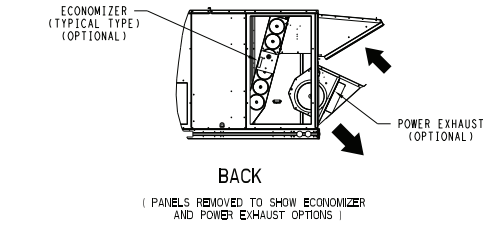

CONNECTION SIZES	
A	1 3/8" DIA [35] FIELD POWER SUPPLY KNOCKOUT
B	3" DIA [76] FIELD POWER SUPPLY KNOCKOUT
C	3 5/8" DIA [92] FIELD POWER SUPPLY KNOCKOUT
D	7/8" DIA [22] FIELD CONTROL WIRING HOLE
F	3/4"-14 NPT GAS CONNECTION (NOT SHOWN)
G	7/8" DIA [22] FIELD CONTROL WIRING KNOCKOUT

- NOTES:
1. DIMENSIONS ARE IN INCHES, DIMENSIONS IN [] ARE IN MILLIMETERS.
 2. CENTER OF GRAVITY
 3. DIRECTION OF AIR FLOW
 4. ALL VIEW DRAWN USING 3RD ANGLE

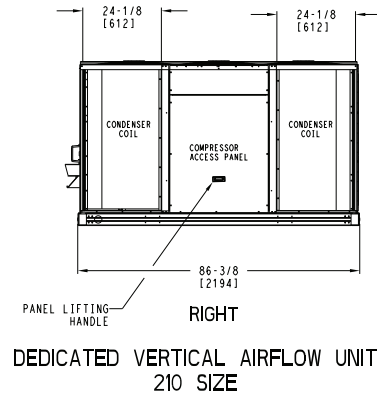
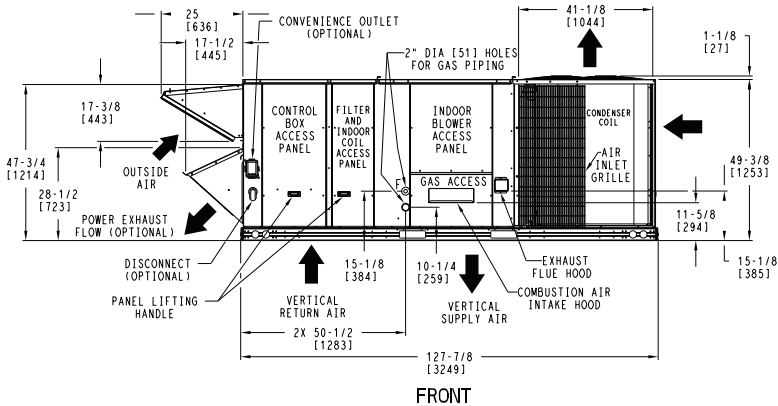

ITC CLASSIFICATION	SHEET	DATE	SUPERCEDES	RGF 210 SINGLE ZONE ELECTRICAL COOLING WITH GAS HEAT	50HE004899	REV
U.S. ECCN:NSR	1 OF 5	05/21/24	-			-

RGF210 Base Unit Dimensions (cont)



THIS DOCUMENT IS THE PROPERTY OF CARRIER CORPORATION AND IS DELIVERED UPON THE EXPRESS CONDITION THAT THE CONTENTS WILL NOT BE DISCLOSED OR USED WITHOUT WRITTEN CONSENT.

SUBMISSION OF THESE DRAWINGS OR DOCUMENTS DOES NOT CONSTITUTE PART PERFORMANCE OR ACCEPTANCE OF CONTRACT.

CONNECTION SIZES	
A	1 3/8" DIA [35] FIELD POWER SUPPLY KNOCKOUT
B	3" DIA [76] FIELD POWER SUPPLY KNOCKOUT
C	3 5/8" DIA [92] FIELD POWER SUPPLY KNOCKOUT
D	7/8" DIA [22] FIELD CONTROL WIRING HOLE
F	3/4"-14 NPT GAS CONNECTION (NOT SHOWN)
G	7/8" DIA [22] FIELD CONTROL WIRING KNOCKOUT

- NOTES:
1. DIMENSIONS ARE IN INCHES. DIMENSIONS IN [] ARE IN MILLIMETERS.
 2. CENTER OF GRAVITY
 3. DIRECTION OF AIR FLOW
 4. ALL VIEW DRAWN USING 3RD ANGLE

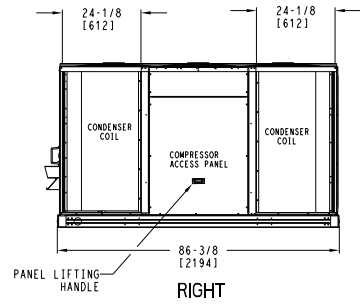
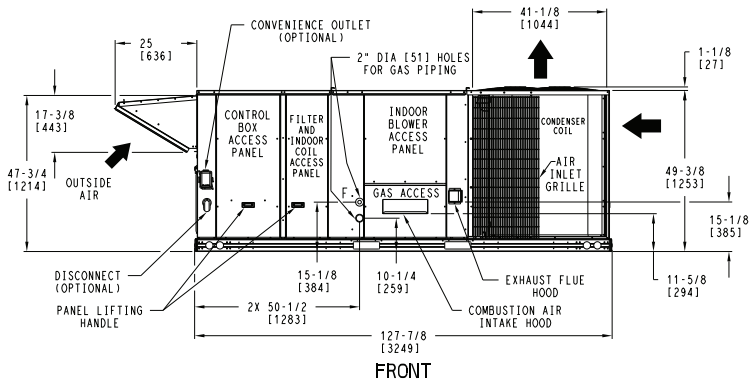
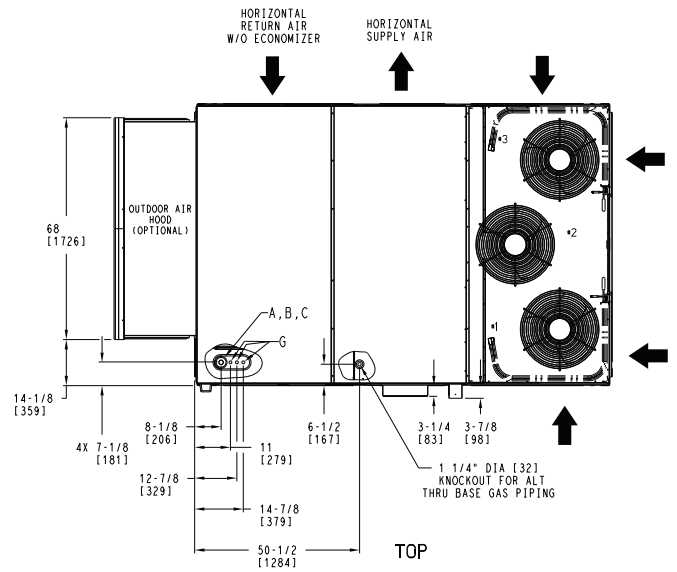
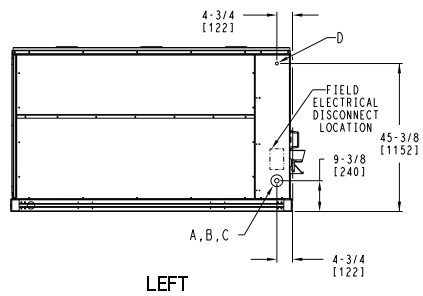
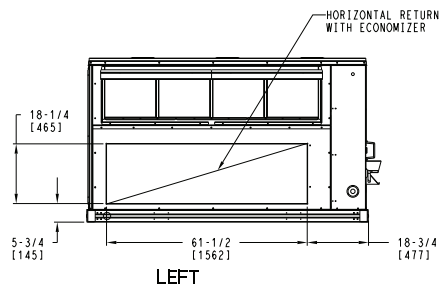
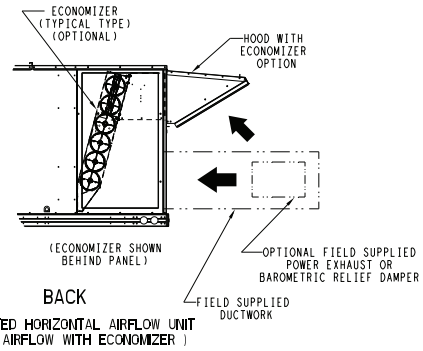

DEDICATED HORIZONTAL AIRFLOW UNIT 210 SIZE

ITC CLASSIFICATION	SHEET	DATE	SUPERCEDES	RGF 210 SINGLE ZONE ELECTRICAL COOLING WITH GAS HEAT	50HE004899	REV
U.S. ECCN:NSR	2 OF 5	05/21/24	-			-

RGF210 Base Unit Dimensions (cont)

CONNECTION SIZES	
E	3/4"-14 NPT CONDENSATE DRAIN



THIS DOCUMENT IS THE PROPERTY OF CARRIER CORPORATION AND IS DELIVERED UPON THE EXPRESS CONDITION THAT THE CONTENTS WILL NOT BE DISCLOSED OR USED WITHOUT WRITTEN CONSENT.

SUBMISSION OF THESE DRAWINGS OR DOCUMENTS DOES NOT CONSTITUTE PART PERFORMANCE OR ACCEPTANCE OF CONTRACT.

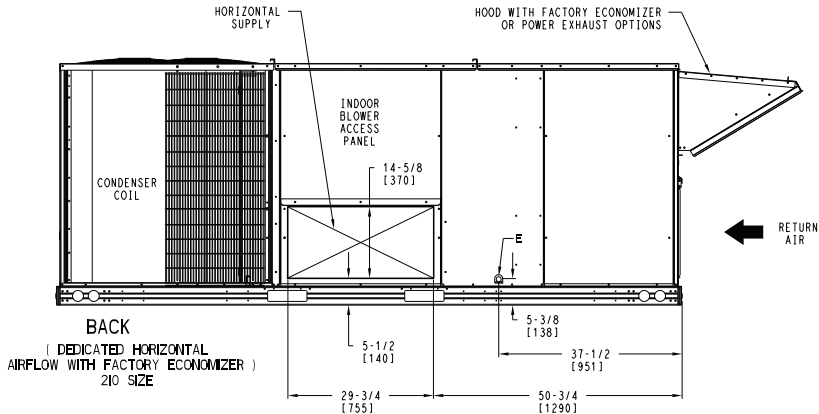
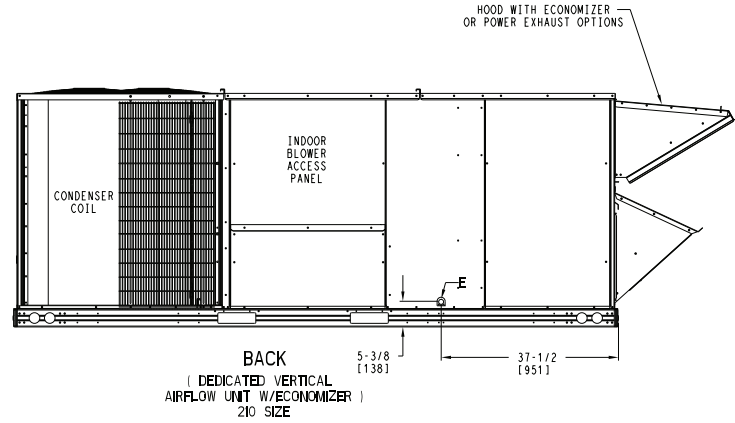
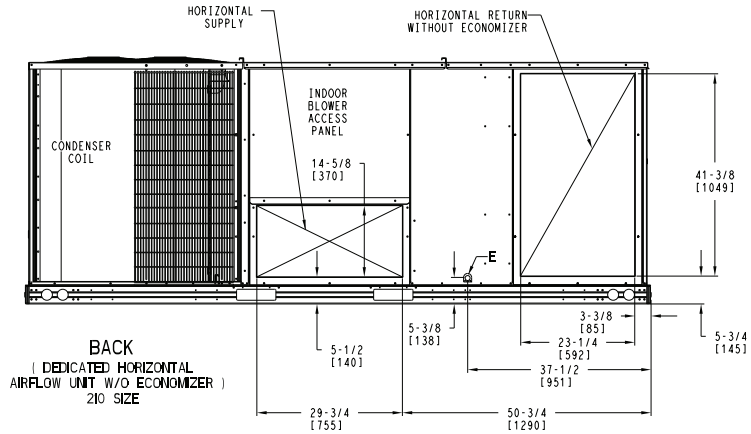

ITC CLASSIFICATION	SHEET	DATE	SUPERCEDES	RGF 210 SINGLE ZONE ELECTRICAL COOLING WITH GAS HEAT	50HE004899	REV
U.S. ECCN:NSR	3 OF 5	05/21/24	-			-

RGF210 Base Unit Dimensions (cont)

UNIT	STD UNIT WEIGHT *		CORNER WEIGHT (A)		CORNER WEIGHT (B)		CORNER WEIGHT (C)		CORNER WEIGHT (D)		C.G.		
	LBS.	KG.	LBS.	KG.	LBS.	KG.	LBS.	KG.	LBS.	KG.	X	Y	Z
RGF 210	1800	816	383	174	479	217	521	236	417	189	71 [1803]	45 [1143]	16 1/2 [419]



THIS DOCUMENT IS THE PROPERTY OF CARRIER CORPORATION AND IS DELIVERED UPON THE EXPRESS CONDITION THAT THE CONTENTS WILL NOT BE DISCLOSED OR USED WITHOUT WRITTEN CONSENT.

SUBMISSION OF THESE DRAWINGS OR DOCUMENTS DOES NOT CONSTITUTE PART PERFORMANCE OR ACCEPTANCE OF CONTRACT.

* STANDARD UNIT WEIGHT IS WITH LOW GAS HEAT AND WITHOUT PACKAGING. FOR OTHER OPTIONS AND ACCESSORIES, REFER TO THE PRODUCT DATA CATALOG.

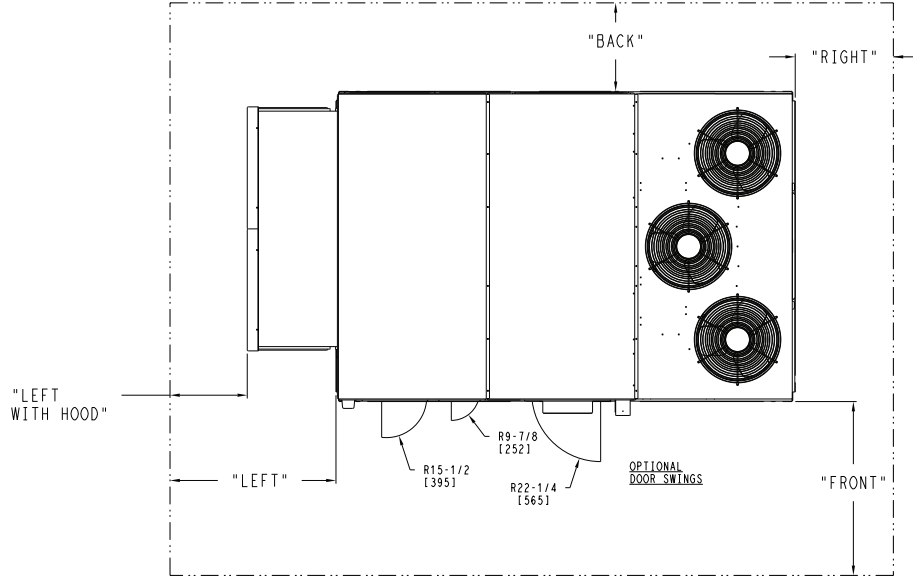
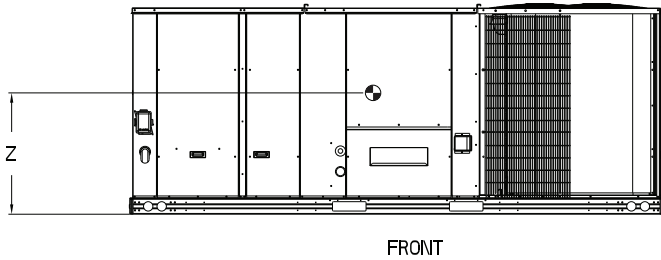
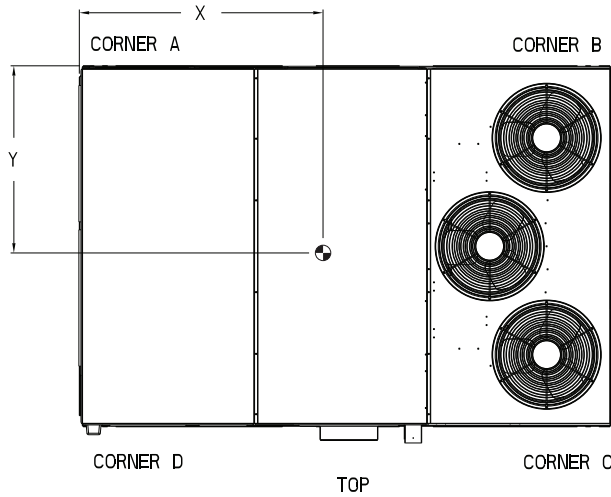

NOTES:

- CLEARANCE ABOVE THE UNIT TO BE 72"
- FOR ALL MINIMUM CLEARANCES LOCAL CODES OR JURISDICTIONS MAY PREVAIL.

SURFACE	CLEARANCE		OPERATING CLEARANCE
	SERVICE WITH CONDUCTIVE BARRIER	SERVICE WITH NONCONDUCTIVE BARRIER	
FRONT	48 [1219mm]	36 [914mm]	18 [457mm]
LEFT	48 [1219mm]	42 [1067mm]	18 [457mm]
BACK	42 [1067mm]	36 [914mm]	18 [457mm]
LEFT WITH HOOD	36 [914mm]	36 [914mm]	18 [457mm]
RIGHT	36 [914mm]	36 [914mm]	18 [457mm]
TOP	72 [1829mm]	72 [1829mm]	72 [1829mm]

ITC CLASSIFICATION U.S. ECCN: NSR	SHEET 4 OF 5	DATE 05/21/24	SUPERCEDES -	RGF 210 SINGLE ZONE ELECTRICAL COOLING WITH GAS HEAT	50HE004899	REV -
--------------------------------------	-----------------	------------------	-----------------	--	------------	----------

RGF210 Base Unit Dimensions (cont)



THIS DOCUMENT IS THE PROPERTY OF CARRIER CORPORATION AND IS DELIVERED UPON THE EXPRESS CONDITION THAT THE CONTENTS WILL NOT BE DISCLOSED OR USED WITHOUT WRITTEN CONSENT.

SUBMISSION OF THESE DRAWINGS OR DOCUMENTS DOES NOT CONSTITUTE PART PERFORMANCE OR ACCEPTANCE OF CONTRACT.

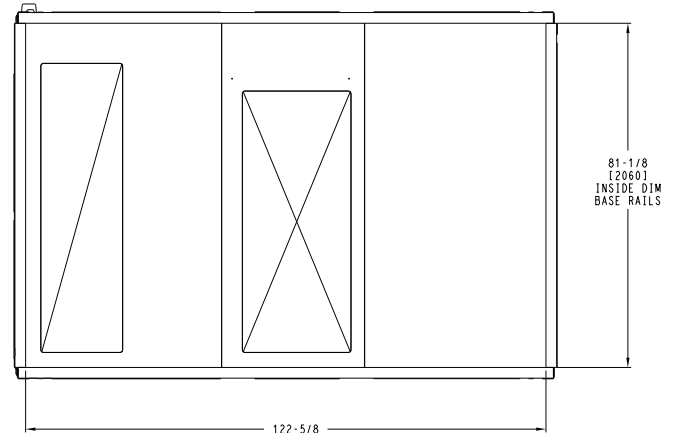
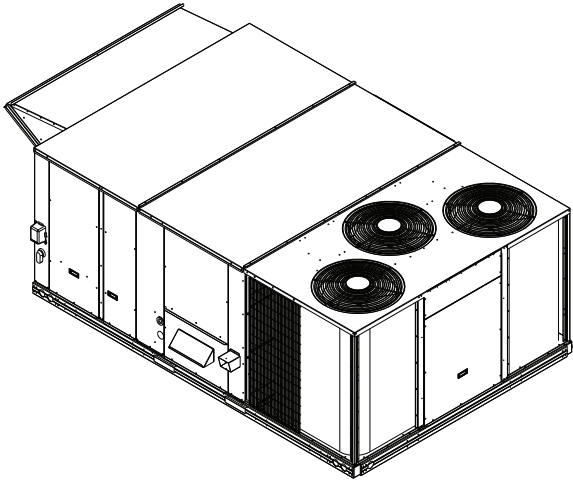

BOTTOM
INSIDE BASERAIL DIMENSIONS

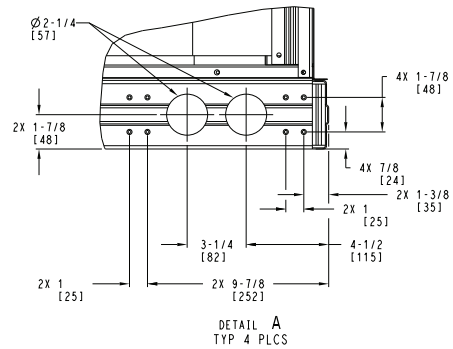
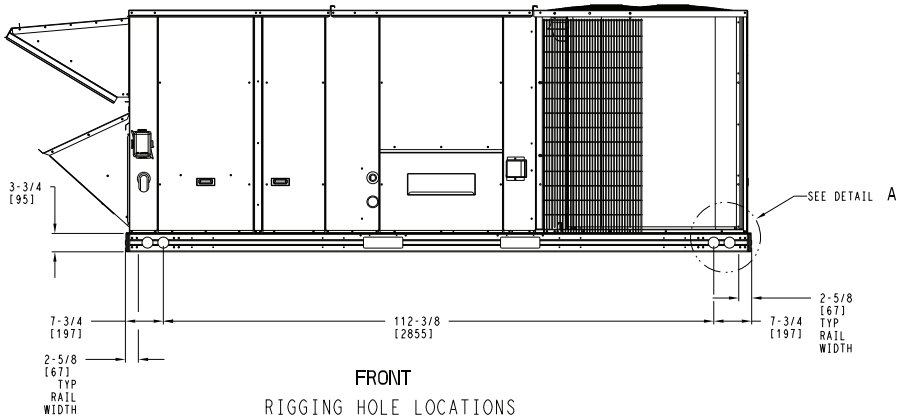

ITC CLASSIFICATION U.S. ECCN:NSR	SHEET 5 OF 5	DATE 05/21/24	SUPERCEDES -	RGF 210 SINGLE ZONE ELECTRICAL COOLING WITH GAS HEAT	50HE004899	REV -
-------------------------------------	-----------------	------------------	-----------------	---	------------	----------

RGF240-300 Base Unit Dimensions



THIS DOCUMENT IS THE PROPERTY OF CARRIER CORPORATION AND IS DELIVERED UPON THE EXPRESS CONDITION THAT THE CONTENTS WILL NOT BE DISCLOSED OR USED WITHOUT WRITTEN CONSENT. SUBMISSION OF THESE DRAWINGS OR DOCUMENTS DOES NOT CONSTITUTE PART PERFORMANCE OR ACCEPTANCE OF CONTRACT.

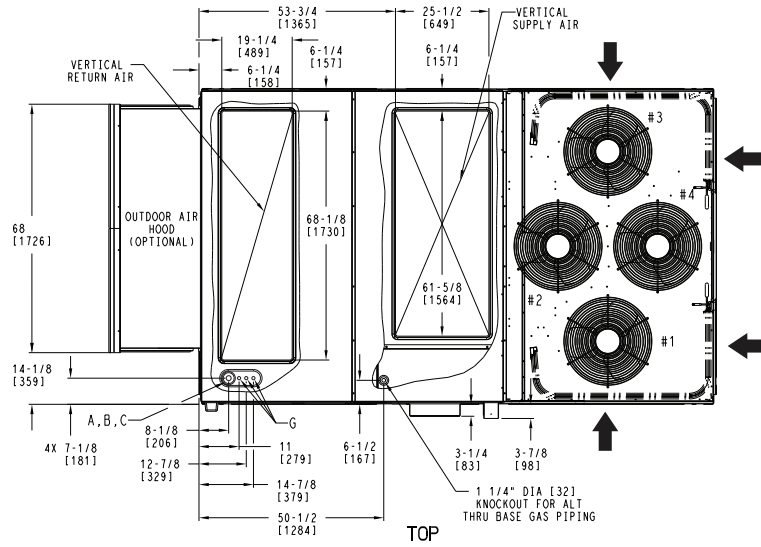
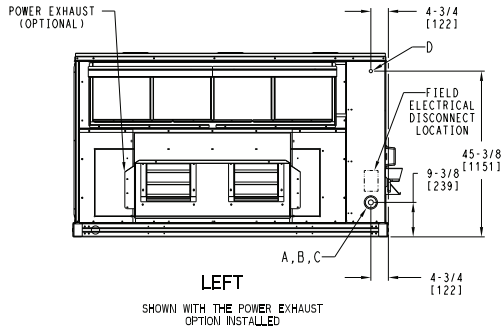
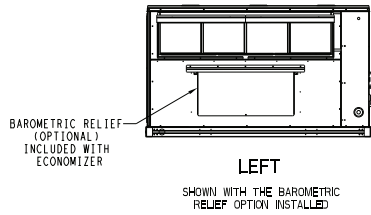
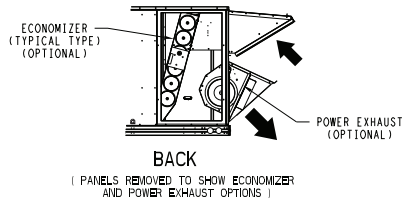

CONNECTION SIZES	
A	1 3/8" DIA [35] FIELD POWER SUPPLY KNOCKOUT
B	3" DIA [76] FIELD POWER SUPPLY KNOCKOUT
C	3 5/8" DIA [92] FIELD POWER SUPPLY KNOCKOUT
D	7/8" DIA [22] FIELD CONTROL WIRING HOLE
F	3/4"-14 NPT GAS CONNECTION (NOT SHOWN)
G	7/8" DIA [22] FIELD CONTROL WIRING KNOCKOUT

UNIT	H
24 SIZE	49-3/8 [1253]
28 SIZE	57-3/8 [1456]

- NOTES:
1. DIMENSIONS ARE IN INCHES, DIMENSIONS IN [] ARE IN MILLIMETERS.
 2. CENTER OF GRAVITY
 3. DIRECTION OF AIR FLOW
 4. ALL VIEW DRAWN USING 3RD ANGLE

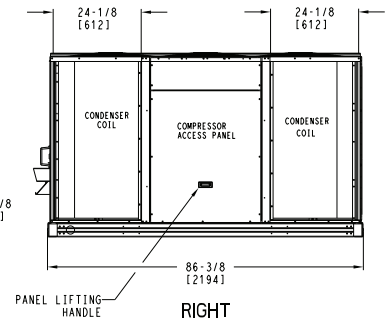
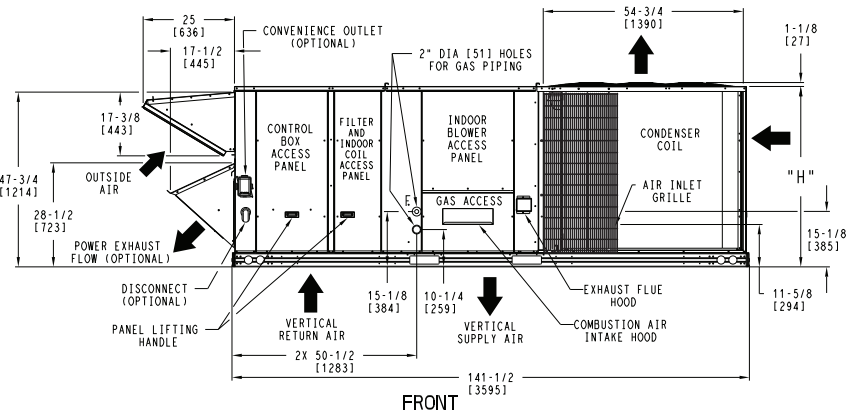

DEDICATED VERTICAL AIRFLOW UNIT
240, 300 SIZE

ITC CLASSIFICATION	SHEET	DATE	SUPERCEDES	RGF 240,300 SINGLE ZONE ELECTRICAL COOLING WITH GAS HEAT	50HE004901	REV
U.S. ECCN:NSR	1 OF 5	05/21/24	-			-

RGF240-300 Base Unit Dimensions (cont)

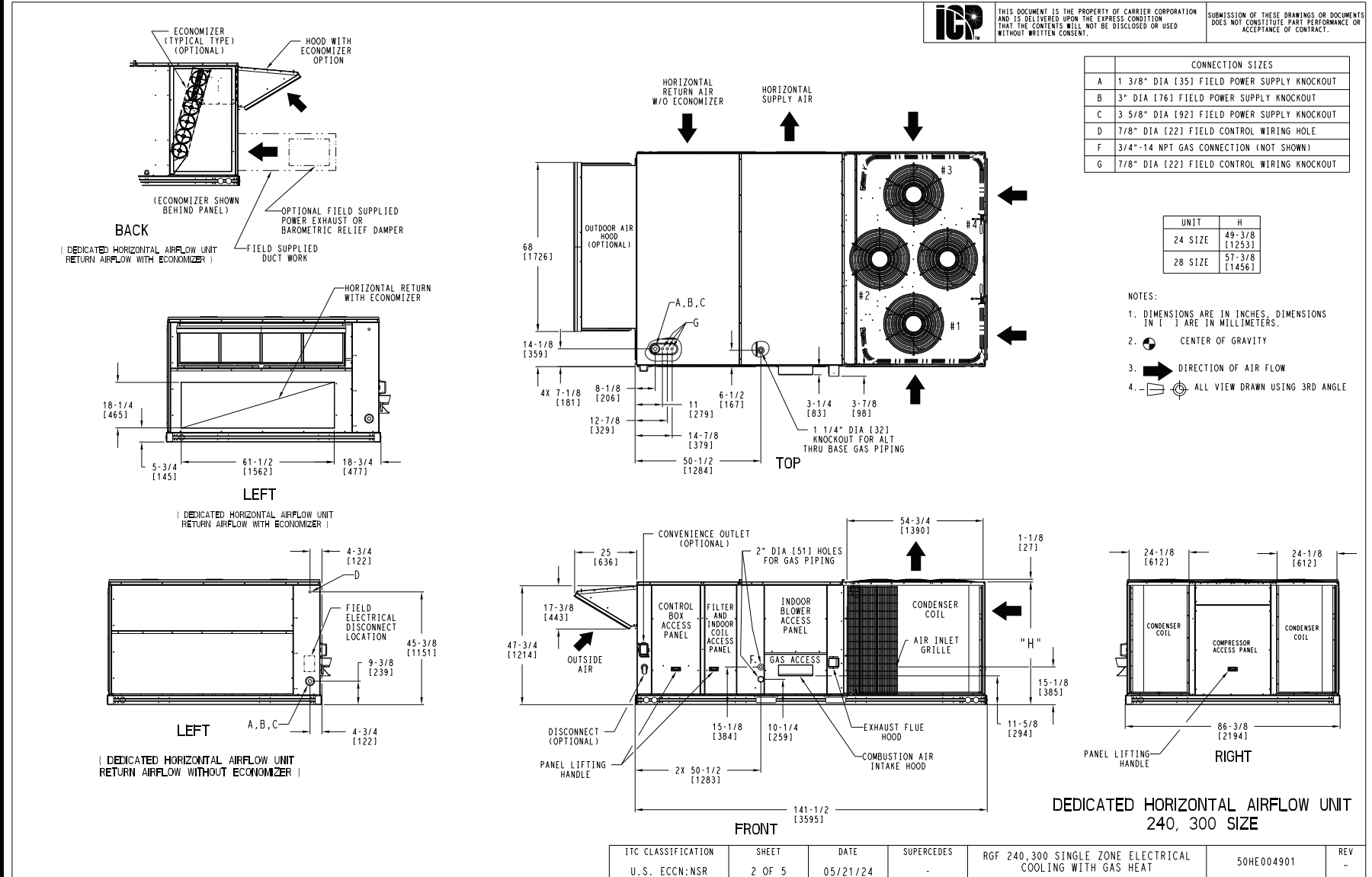

ITC CLASSIFICATION	SHEET	DATE	SUPERCEDES	RGF 240,300 SINGLE ZONE ELECTRICAL COOLING WITH GAS HEAT	50HE004901	REV
U.S. ECCN:NSR	2 OF 5	05/21/24	-			-

RGF240-300 Base Unit Dimensions (cont)

CONNECTION SIZES	
E	3/4" - 1/4 NPT CONDENSATE DRAIN

UNIT	G
240 SIZE	41-3/8 [1049]
300 SIZE	49-1/4 [1251]



THIS DOCUMENT IS THE PROPERTY OF CARRIER CORPORATION AND IS DELIVERED UPON THE EXPRESS CONDITION THAT THE CONTENTS WILL NOT BE DISCLOSED OR USED WITHOUT WRITTEN CONSENT.

SUBMISSION OF THESE DRAWINGS OR DOCUMENTS DOES NOT CONSTITUTE PART PERFORMANCE OR ACCEPTANCE OF CONTRACT.

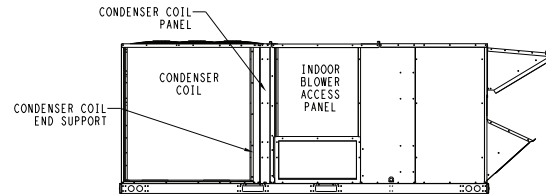
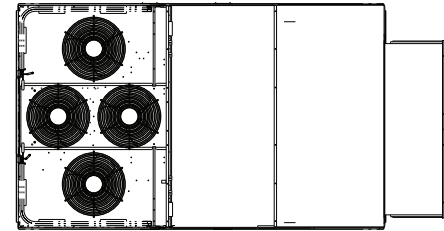
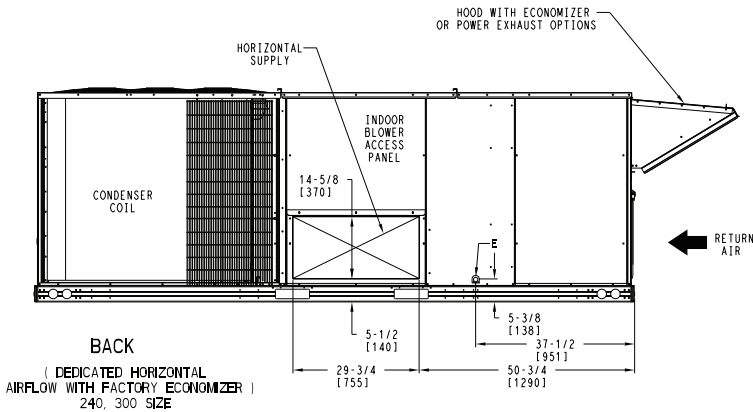
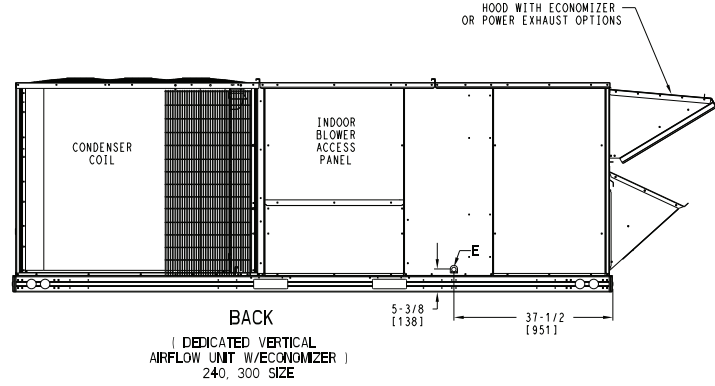
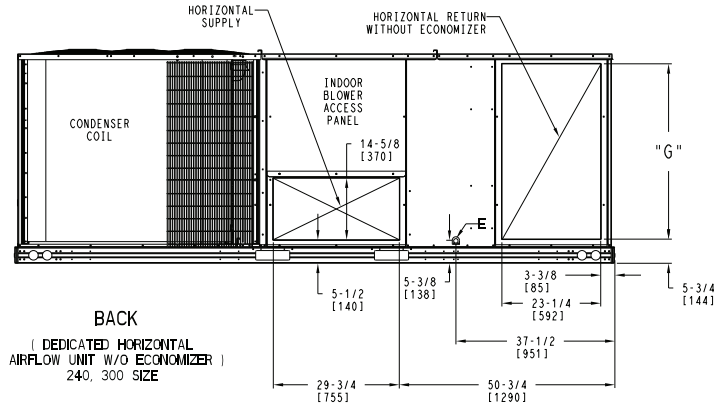

ITC CLASSIFICATION	SHEET	DATE	SUPERCEDES	RGF 240,300 SINGLE ZONE ELECTRICAL COOLING WITH GAS HEAT	50HE004901	REV
U.S. ECCN:NSR	3 OF 5	05/21/24	-			-

RGF240-300 Base Unit Dimensions (cont)

UNIT	STD UNIT WEIGHT *		CORNER WEIGHT (A)		CORNER WEIGHT (B)		CORNER WEIGHT (C)		CORNER WEIGHT (D)		C.G.					
	LBS.	KG.	LBS.	KG.	LBS.	KG.	LBS.	KG.	LBS.	KG.	X	Y	Z			
RGF 240	2000	907	429	195	505	229	576	261	489	222	76 1/2	[1943]	46	[1168]	16 1/2	[419]
RGF 300	2174	986	458	208	583	264	634	288	498	226	79 1/4	[2013]	45	[1143]	19	[483]



THIS DOCUMENT IS THE PROPERTY OF CARRIER CORPORATION AND IS DELIVERED UPON THE EXPRESS CONDITION THAT THE CONTENTS WILL NOT BE DISCLOSED OR USED WITHOUT WRITTEN CONSENT.

SUBMISSION OF THESE DRAWINGS OR DOCUMENTS DOES NOT CONSTITUTE PART PERFORMANCE OR ACCEPTANCE OF CONTRACT.

* STANDARD UNIT WEIGHT IS WITH LOW GAS HEAT AND WITHOUT PACKAGING. FOR OTHER OPTIONS AND ACCESSORIES, REFER TO THE PRODUCT DATA CATALOG.

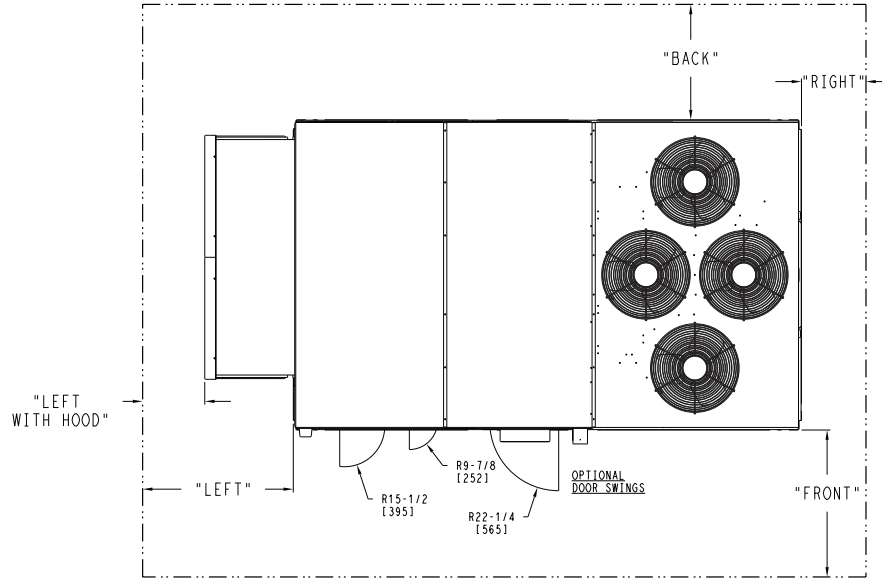
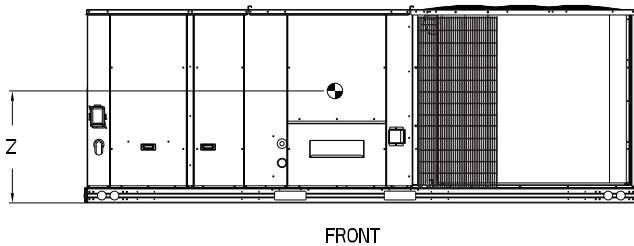
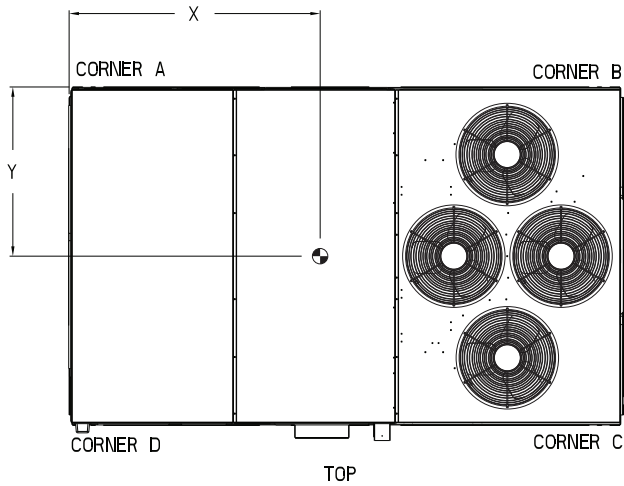

NOTES:

1. CLEARANCE ABOVE THE UNIT TO BE 72"
2. FOR ALL MINIMUM CLEARANCES LOCAL CODES OR JURISDICTIONS MAY PREVAIL.

SURFACE	CLEARANCE		OPERATING CLEARANCE
	SERVICE WITH CONDUCTIVE BARRIER	SERVICE WITH NONCONDUCTIVE BARRIER	
FRONT	48 [1219mm]	36 [914mm]	18 [457mm]
LEFT	48 [1219mm]	42 [1067mm]	18 [457mm]
BACK	42 [1067mm]	36 [914mm]	18 [457mm]
LEFT WITH HOOD	36 [914mm]	36 [914mm]	18 [457mm]
RIGHT	36 [914mm]	36 [914mm]	18 [457mm]
TOP	72 [1829mm]	72 [1829mm]	72 [1829mm]

ITC CLASSIFICATION U.S. ECCN:NSR	SHEET 4 OF 5	DATE 05/21/24	SUPERCEDES -	RGF 240,300 SINGLE ZONE ELECTRICAL COOLING WITH GAS HEAT	50HE004901	REV -
-------------------------------------	-----------------	------------------	-----------------	--	------------	----------

RGF240-300 Base Unit Dimensions (cont)



THIS DOCUMENT IS THE PROPERTY OF CARRIER CORPORATION AND IS DELIVERED UPON THE EXPRESS CONDITION THAT THE CONTENTS WILL NOT BE DISCLOSED OR USED WITHOUT WRITTEN CONSENT.

SUBMISSION OF THESE DRAWINGS OR DOCUMENTS DOES NOT CONSTITUTE PART PERFORMANCE OR ACCEPTANCE OF CONTRACT.

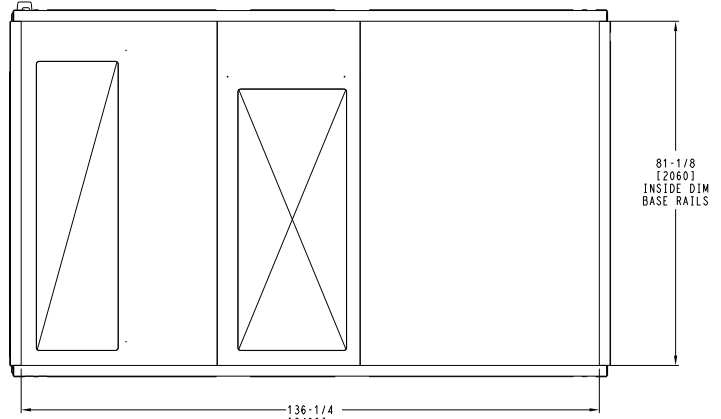
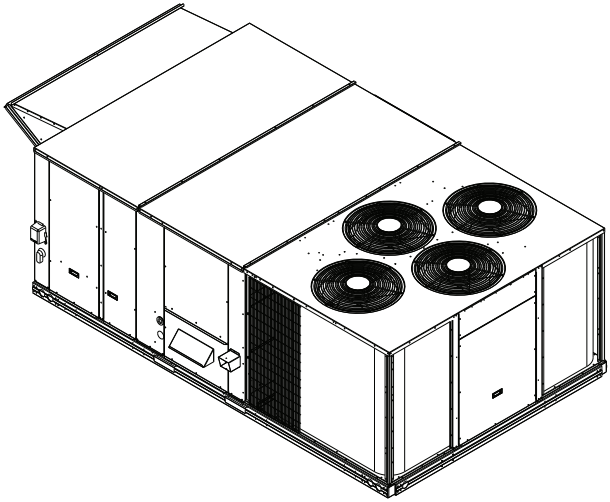

BOTTOM
INSIDE BASERAIL DIMENSIONS

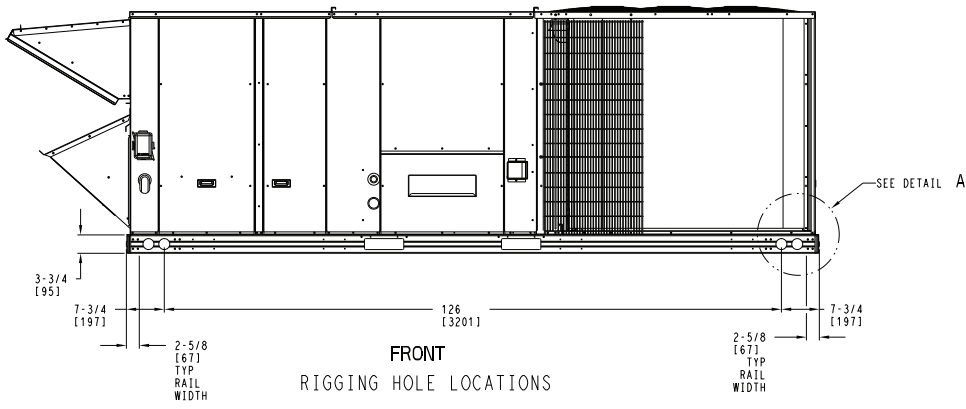

FRONT
RIGGING HOLE LOCATIONS

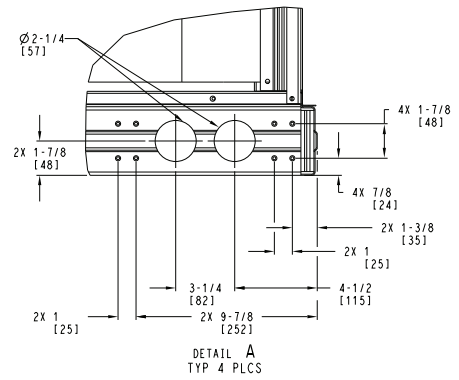

DETAIL A
TYP 4 PLCS

ITC CLASSIFICATION	SHEET	DATE	SUPERCEDES	RGF 240,300 SINGLE ZONE ELECTRICAL COOLING WITH GAS HEAT	50HE004901	REV
U.S. ECCN:NSR	5 OF 5	05/21/24	-			-

RGF336 Base Unit Dimensions



THIS DOCUMENT IS THE PROPERTY OF CARRIER CORPORATION AND IS DELIVERED UPON THE EXPRESS CONDITION THAT THE CONTENTS WILL NOT BE DISCLOSED OR USED WITHOUT WRITTEN CONSENT.

SUBMISSION OF THESE DRAWINGS OR DOCUMENTS DOES NOT CONSTITUTE PART PERFORMANCE OR ACCEPTANCE OF CONTRACT.

CONNECTION SIZES	
A	1 3/8" DIA [35] FIELD POWER SUPPLY KNOCKOUT
B	3" DIA [76] FIELD POWER SUPPLY KNOCKOUT
C	3 5/8" DIA [92] FIELD POWER SUPPLY KNOCKOUT
D	7/8" DIA [22] FIELD CONTROL WIRING HOLE
F	3/4"-14 NPT GAS CONNECTION (NOT SHOWN)
G	7/8" DIA [22] FIELD CONTROL WIRING KNOCKOUT

- NOTES:
1. DIMENSIONS ARE IN INCHES, DIMENSIONS IN [] ARE IN MILLIMETERS.
 2. CENTER OF GRAVITY
 3. DIRECTION OF AIR FLOW
 4. ALL VIEW DRAWN USING 3RD ANGLE

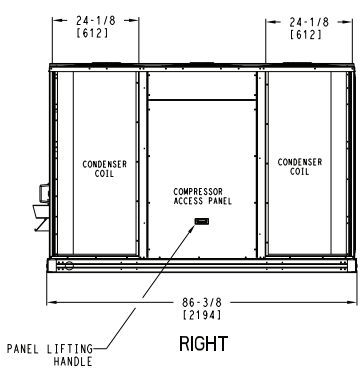
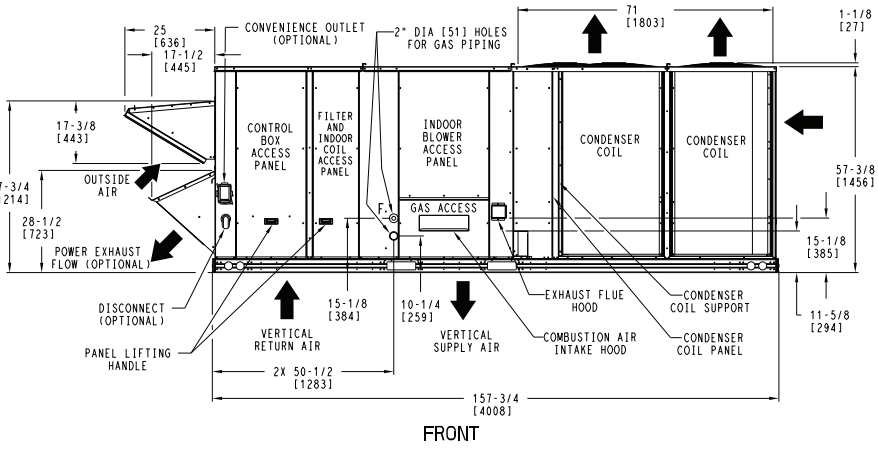
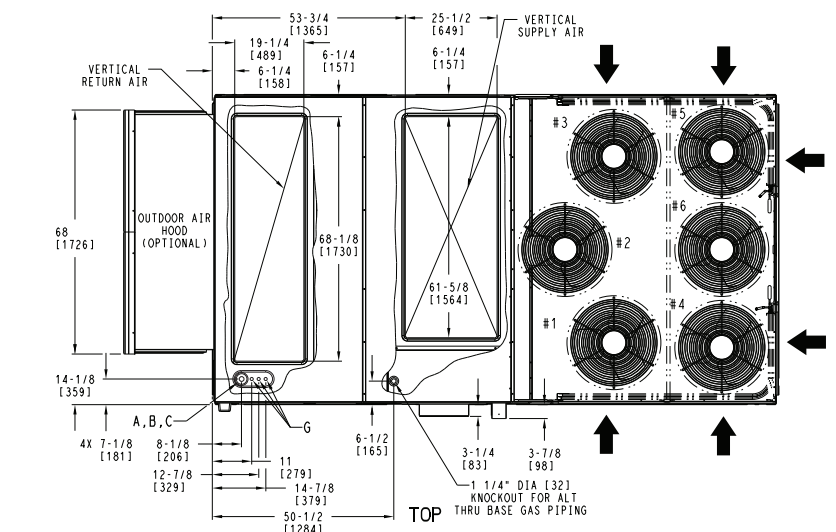
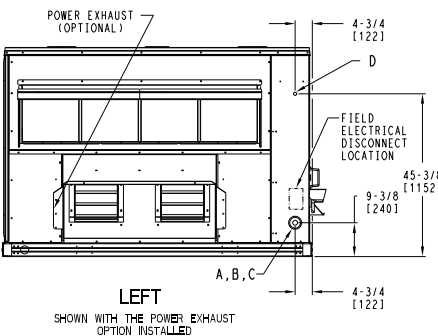
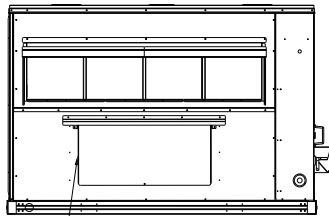
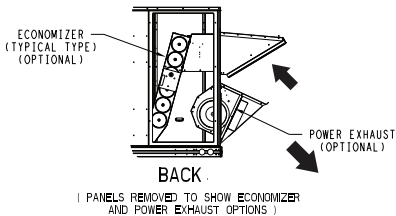

DEDICATED VERTICAL AIRFLOW UNIT
336 SIZE

ITC CLASSIFICATION	SHEET	DATE	SUPERCEDES	RGF 336 SINGLE ZONE ELECTRICAL COOLING WITH GAS HEAT	50HE004903	REV
U.S. ECCN:NSR	1 OF 5	05/21/24	-			-

RGF336 Base Unit Dimensions (cont)

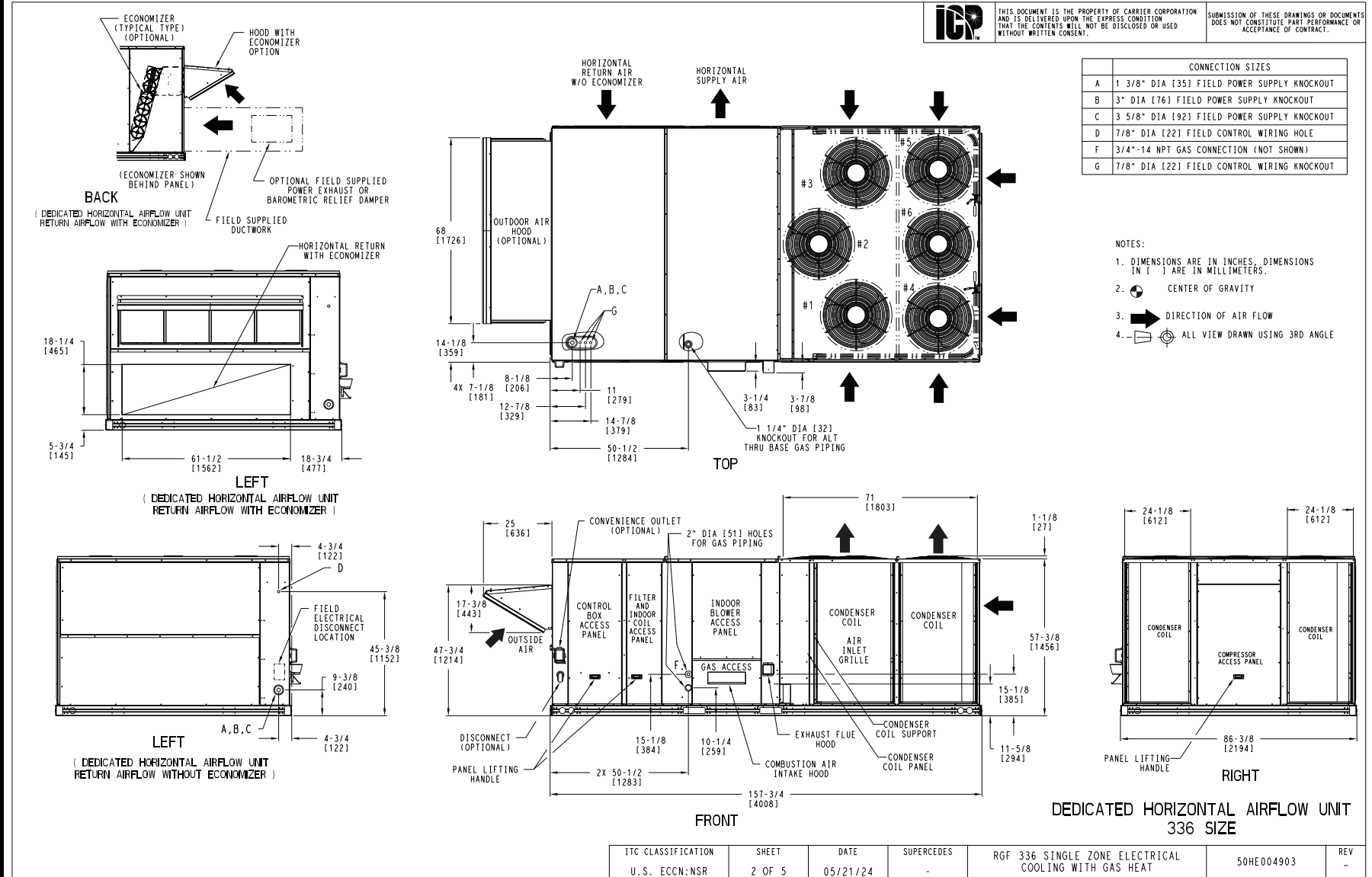

ITC CLASSIFICATION	SHEET	DATE	SUPERCEDES	RGF 336 SINGLE ZONE ELECTRICAL COOLING WITH GAS HEAT	50HE004903	REV
U.S. ECCN:NSR	2 OF 5	05/21/24	-			-

RGF336 Base Unit Dimensions (cont)

CONNECTION SIZES	
E	3/4"-14 NPT CONDENSATE DRAIN



THIS DOCUMENT IS THE PROPERTY OF CARRIER CORPORATION AND IS DELIVERED UPON THE EXPRESS CONDITION THAT THE CONTENTS WILL NOT BE DISCLOSED OR USED WITHOUT WRITTEN CONSENT.

SUBMISSION OF THESE DRAWINGS OR DOCUMENTS DOES NOT CONSTITUTE PART PERFORMANCE OR ACCEPTANCE OF CONTRACT.

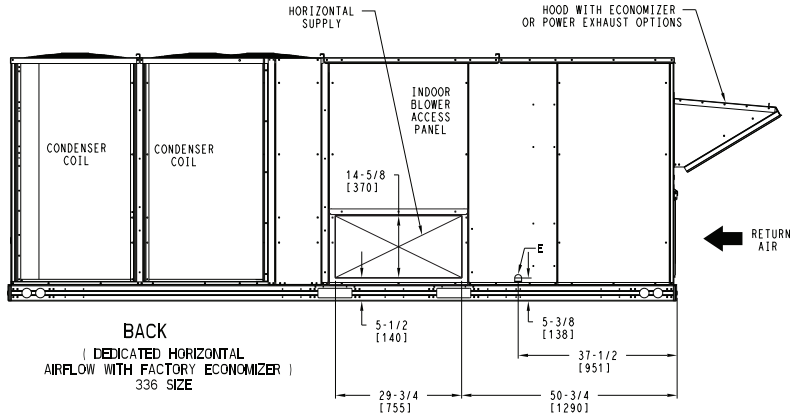
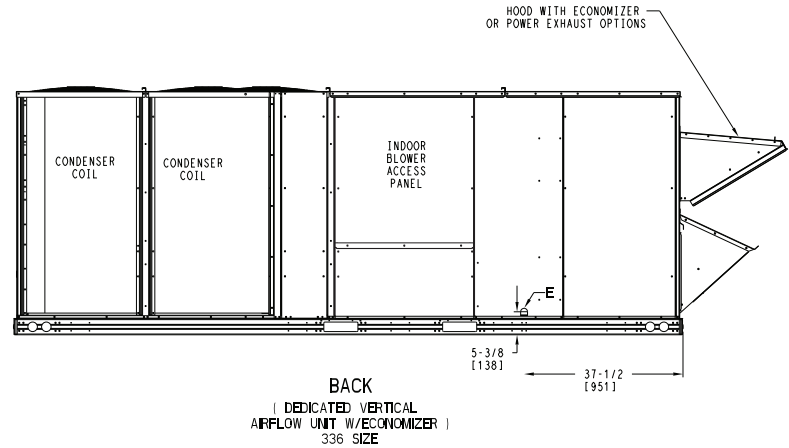
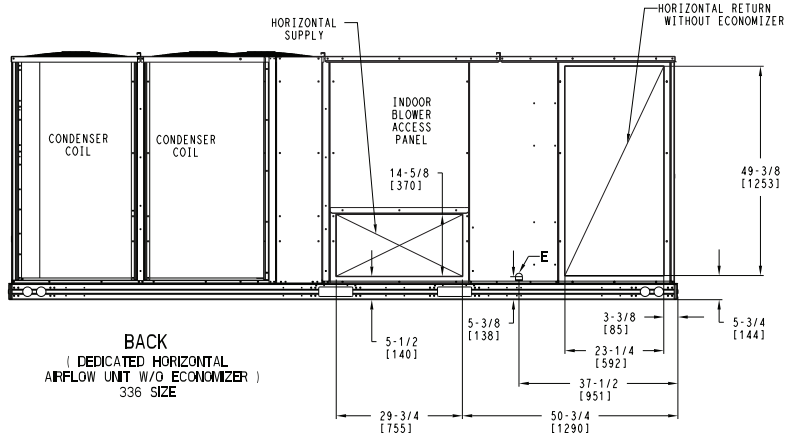

ITC CLASSIFICATION	SHEET	DATE	SUPERCEDES	RGF 336 SINGLE ZONE ELECTRICAL COOLING WITH GAS HEAT	50HE004903	REV
U.S. ECCN:NSR	3 OF 5	05/21/24	-			-

RGF336 Base Unit Dimensions (cont)

UNIT	STD UNIT WEIGHT *		CORNER WEIGHT (A)		CORNER WEIGHT (B)		CORNER WEIGHT (C)		CORNER WEIGHT (D)		C.G.		
	LBS.	KG.	LBS.	KG.	LBS.	KG.	LBS.	KG.	LBS.	KG.	X	Y	Z
RGF 336	2351	1066	529	240	651	295	645	293	525	238	87 [2210]	43 [1092]	19 [483]



THIS DOCUMENT IS THE PROPERTY OF CARRIER CORPORATION AND IS DELIVERED UPON THE EXPRESS CONDITION THAT THE CONTENTS WILL NOT BE DISCLOSED OR USED WITHOUT WRITTEN CONSENT.

SUBMISSION OF THESE DRAWINGS OR DOCUMENTS DOES NOT CONSTITUTE PART PERFORMANCE OR ACCEPTANCE OF CONTRACT.

* STANDARD UNIT WEIGHT IS WITH LOW GAS HEAT AND WITHOUT PACKAGING. FOR OTHER OPTIONS AND ACCESSORIES, REFER TO THE PRODUCT DATA CATALOG.

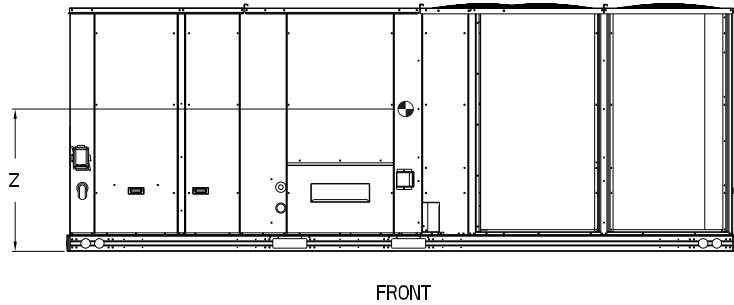
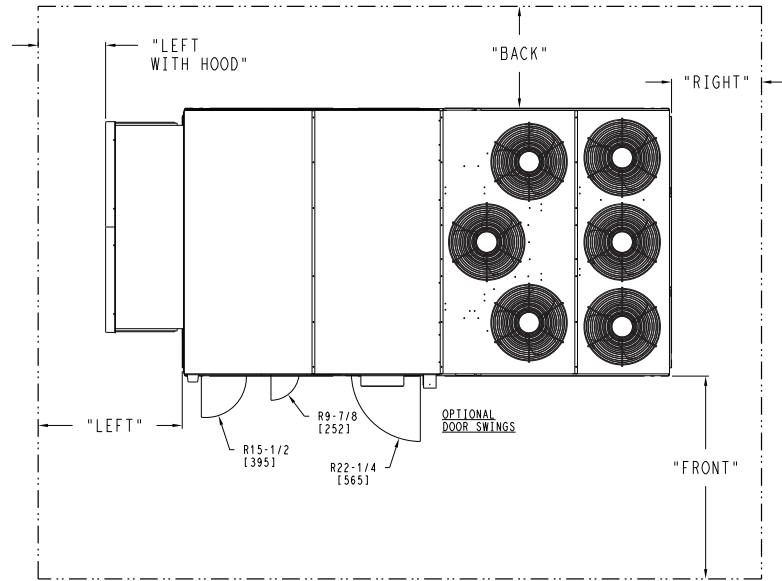
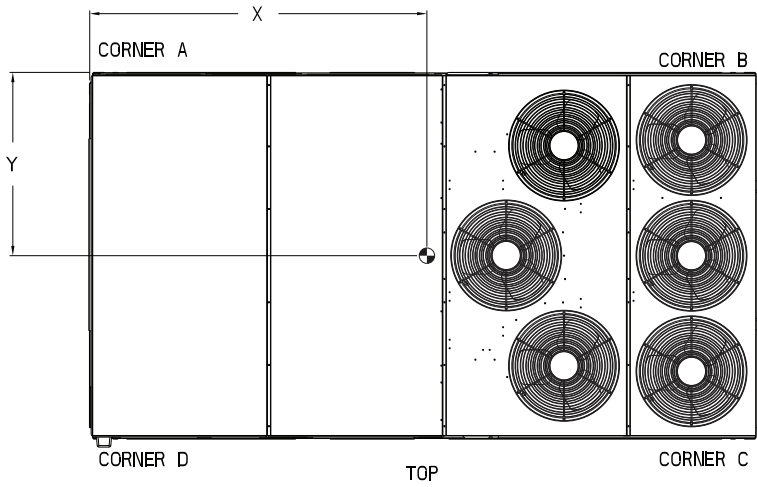

NOTES:

- CLEARANCE ABOVE THE UNIT TO BE 72"
- FOR ALL MINIMUM CLEARANCES LOCAL CODES OR JURISDICTIONS MAY PREVAIL.

SURFACE	CLEARANCE		OPERATING CLEARANCE
	SERVICE WITH CONDUCTIVE BARRIER	SERVICE WITH NONCONDUCTIVE BARRIER	
FRONT	48 [1219mm]	36 [914mm]	18 [457mm]
LEFT	48 [1219mm]	42 [1067mm]	18 [457mm]
BACK	42 [1067mm]	36 [914mm]	18 [457mm]
LEFT WITH HOOD	36 [914mm]	36 [914mm]	18 [457mm]
RIGHT	36 [914mm]	36 [914mm]	18 [457mm]
TOP	72 [1829mm]	72 [1829mm]	72 [1829mm]

ITC CLASSIFICATION U.S. ECCN:NSR	SHEET 4 OF 5	DATE 05/21/24	SUPERCEDES -	RGF 336 SINGLE ZONE ELECTRICAL COOLING WITH GAS HEAT	50HE004903	REV -
-------------------------------------	-----------------	------------------	-----------------	--	------------	----------

RGF336 Base Unit Dimensions (cont)



THIS DOCUMENT IS THE PROPERTY OF CARRIER CORPORATION AND IS DELIVERED UPON THE EXPRESS CONDITION THAT THE CONTENTS WILL NOT BE DISCLOSED OR USED WITHOUT WRITTEN CONSENT.

SUBMISSION OF THESE DRAWINGS OR DOCUMENTS DOES NOT CONSTITUTE PART PERFORMANCE OR ACCEPTANCE OF CONTRACT.

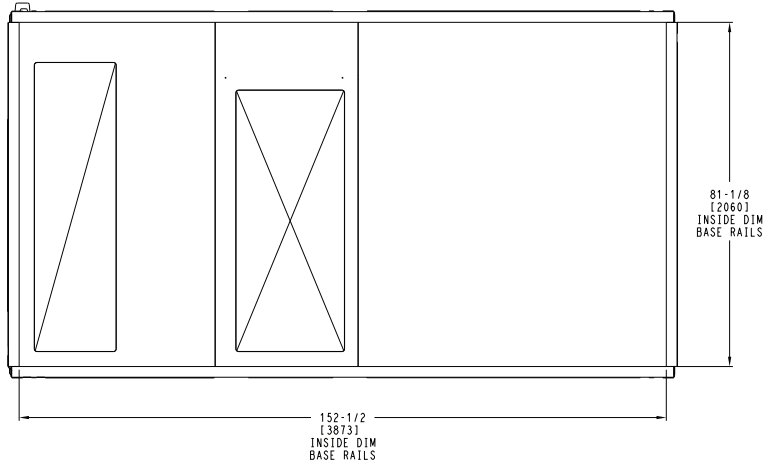
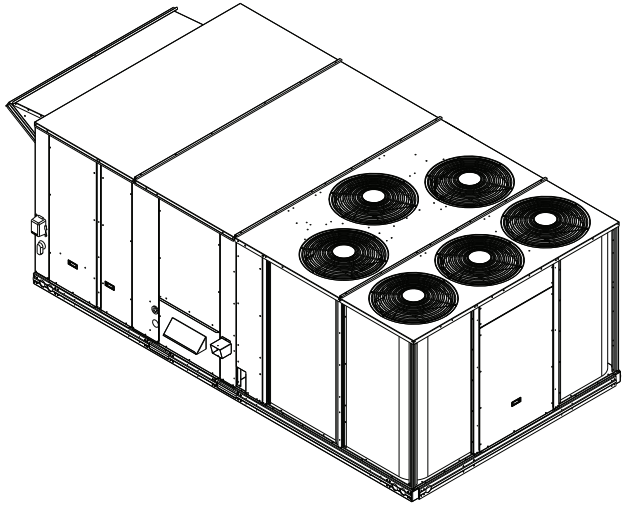

BOTTOM
INSIDE BASERAIL DIMENSIONS

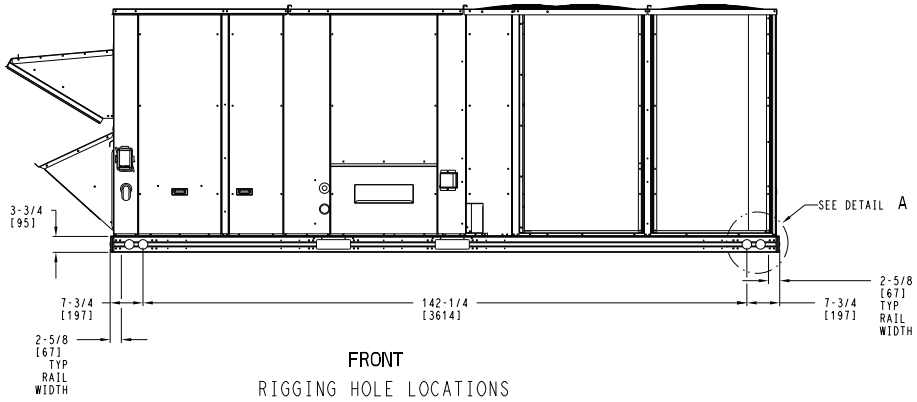

FRONT
RIGGING HOLE LOCATIONS

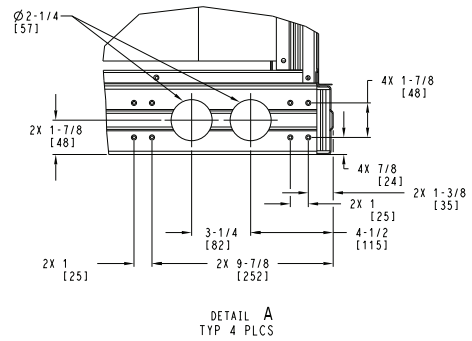

DETAIL A
TYP 4 PLCS

ITC CLASSIFICATION	SHEET	DATE	SUPERCEDES	RGF 336 SINGLE ZONE ELECTRICAL COOLING WITH GAS HEAT	50HE004903	REV
U.S. ECCN:NSR	5 OF 5	05/21/24	-			-

RAF210 Base Unit Dimensions



THIS DOCUMENT IS THE PROPERTY OF CARRIER CORPORATION AND IS DELIVERED UPON THE EXPRESS CONDITION THAT THE CONTENTS WILL NOT BE DISCLOSED OR USED WITHOUT WRITTEN CONSENT.

SUBMISSION OF THESE DRAWINGS OR DOCUMENTS DOES NOT CONSTITUTE PART PERFORMANCE OR ACCEPTANCE OF CONTRACT.

CONNECTION SIZES	
A	1 3/8" DIA [35] FIELD POWER SUPPLY KNOCKOUT
B	3" DIA [76] FIELD POWER SUPPLY KNOCKOUT
C	3 5/8" DIA [92] FIELD POWER SUPPLY KNOCKOUT
D	7/8" DIA [22] FIELD CONTROL WIRING HOLE
G	7/8" DIA [22] FIELD CONTROL WIRING KNOCKOUT

- NOTES:
1. DIMENSIONS ARE IN INCHES. DIMENSIONS IN [] ARE IN MILLIMETERS.
 2. CENTER OF GRAVITY
 3. DIRECTION OF AIR FLOW
 4. ALL VIEW DRAWN USING 3RD ANGLE

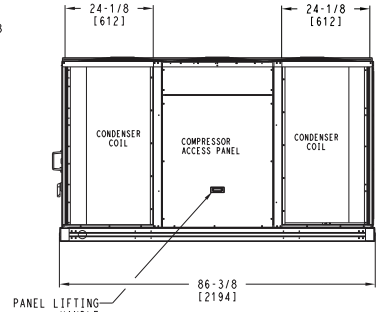
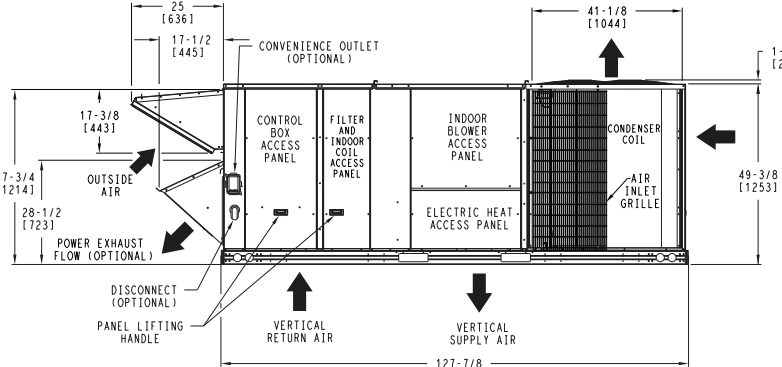
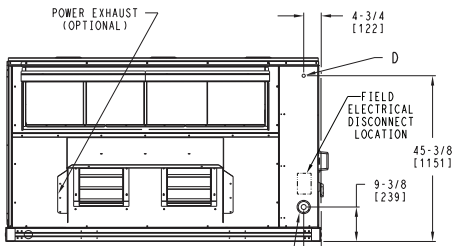
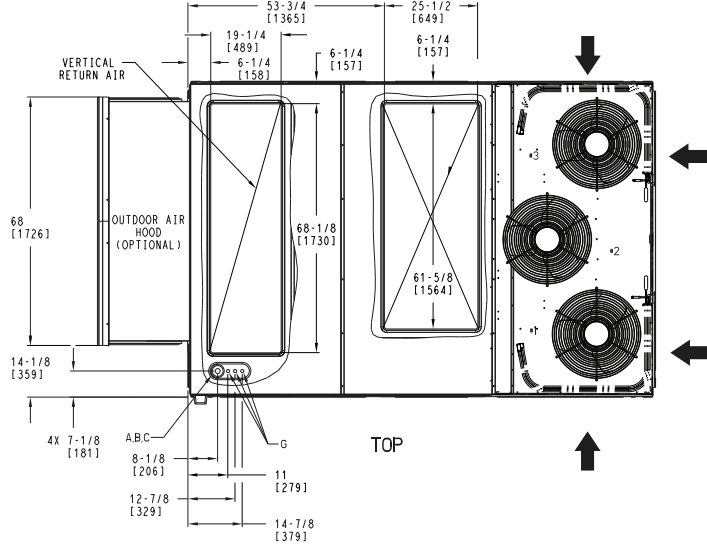
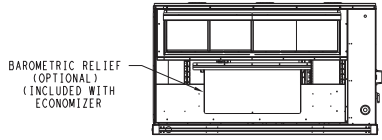
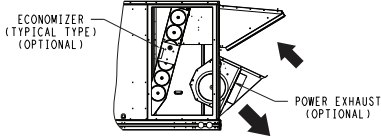

DEDICATED VERTICAL AIRFLOW UNIT 210 SIZE

ITC CLASSIFICATION	SHEET	DATE	SUPERCEDES	RAF 210 SINGLE ZONE ELECTRICAL COOLING WITH ELECTRIC HEAT	50HE004900	REV
U.S. ECCN:NSR	1 OF 5	05/21/24	-			-

RAF210 Base Unit Dimensions (cont)

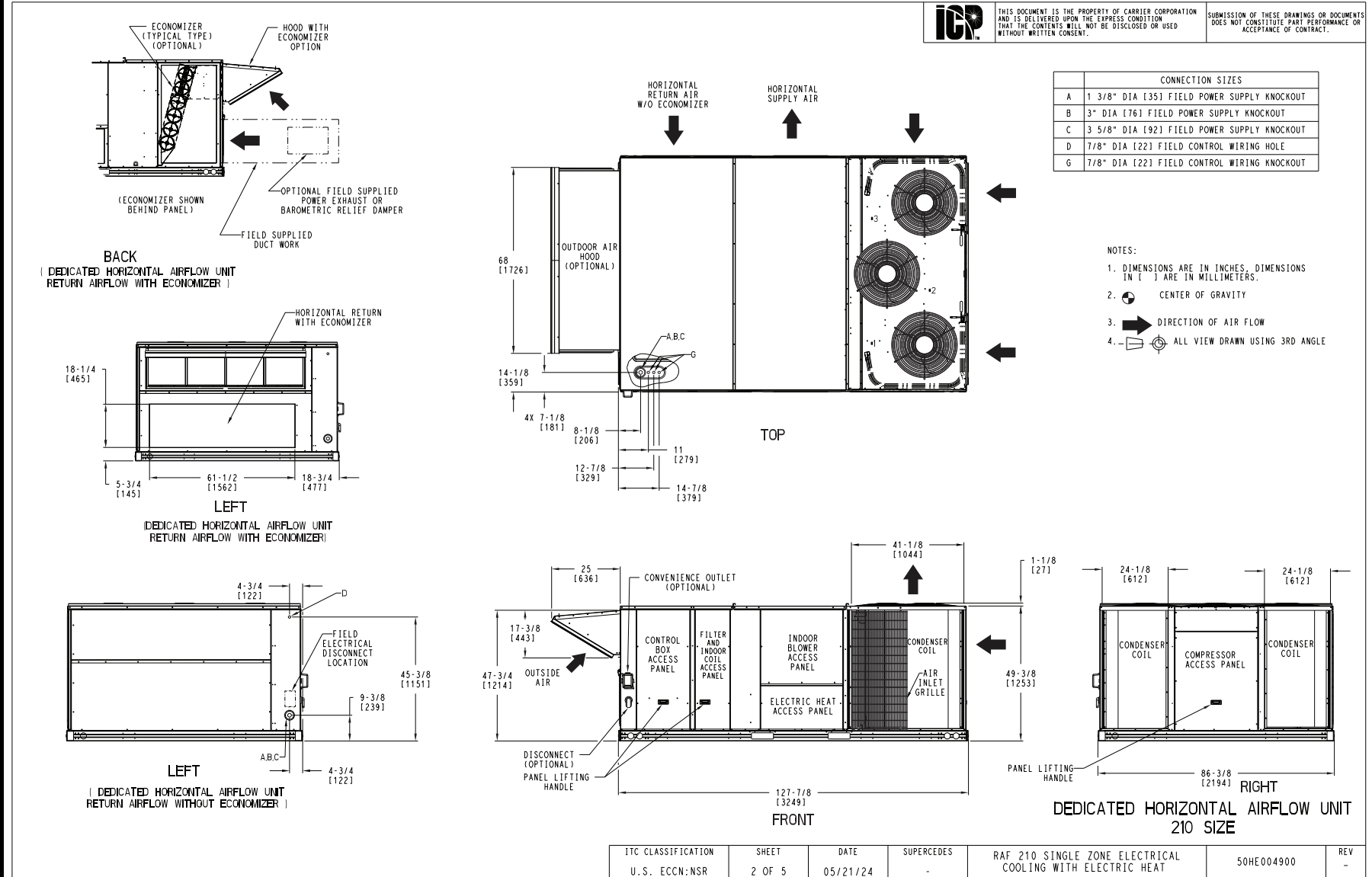

RAF210 Base Unit Dimensions (cont)

CONNECTION SIZES	
E	3/4"-14 NPT CONDENSATE DRAIN



THIS DOCUMENT IS THE PROPERTY OF CARRIER CORPORATION AND IS DELIVERED UPON THE EXPRESS CONDITION THAT THE CONTENTS WILL NOT BE DISCLOSED OR USED WITHOUT WRITTEN CONSENT.

SUBMISSION OF THESE DRAWINGS OR DOCUMENTS DOES NOT CONSTITUTE PART PERFORMANCE OR ACCEPTANCE OF CONTRACT.

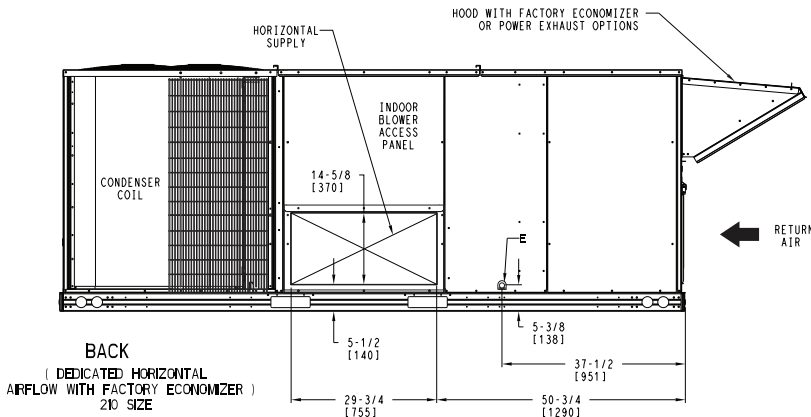
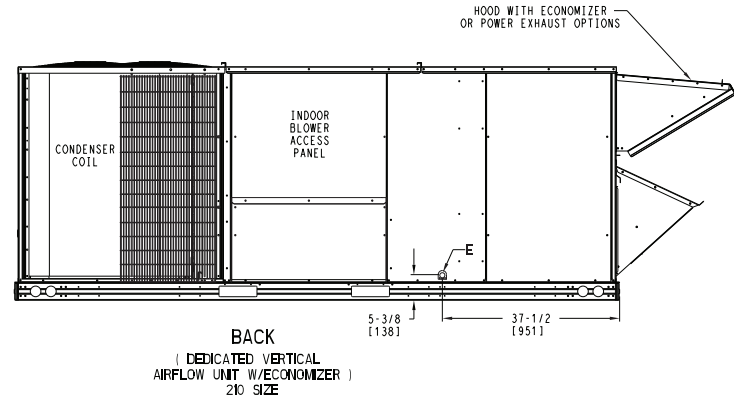
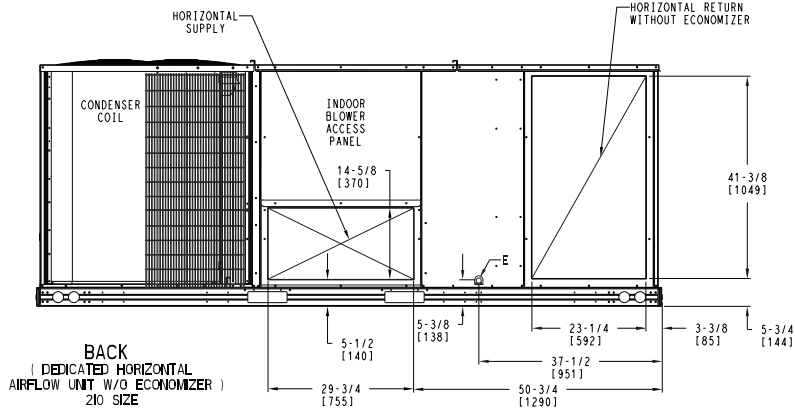

ITC CLASSIFICATION	SHEET	DATE	SUPERCEDES	RAF 210 SINGLE ZONE ELECTRICAL COOLING WITH ELECTRIC HEAT	50HE004900	REV
U.S. ECCN:NSR	3 OF 5	05/21/24	-			-

RAF210 Base Unit Dimensions (cont)

UNIT	STD UNIT WEIGHT #		CORNER WEIGHT (A)		CORNER WEIGHT (B)		CORNER WEIGHT (C)		CORNER WEIGHT (D)		C.G.		
	LBS.	KG.	LBS.	KG.	LBS.	KG.	LBS.	KG.	LBS.	KG.	X	Y	Z
RAF 210	1673	759	356	161	445	202	484	220	388	176	71 [1803]	45 [1143]	16 1/2 [419]



THIS DOCUMENT IS THE PROPERTY OF CARRIER CORPORATION AND IS DELIVERED UPON THE EXPRESS CONDITION THAT THE CONTENTS WILL NOT BE DISCLOSED OR USED WITHOUT WRITTEN CONSENT.

SUBMISSION OF THESE DRAWINGS OR DOCUMENTS DOES NOT CONSTITUTE PART PERFORMANCE OR ACCEPTANCE OF CONTRACT.

* STANDARD UNIT WEIGHT IS WITHOUT ELECTRIC HEAT AND WITHOUT PACKAGING. FOR OTHER OPTIONS AND ACCESSORIES, REFER TO THE PRODUCT DATA CATALOG.

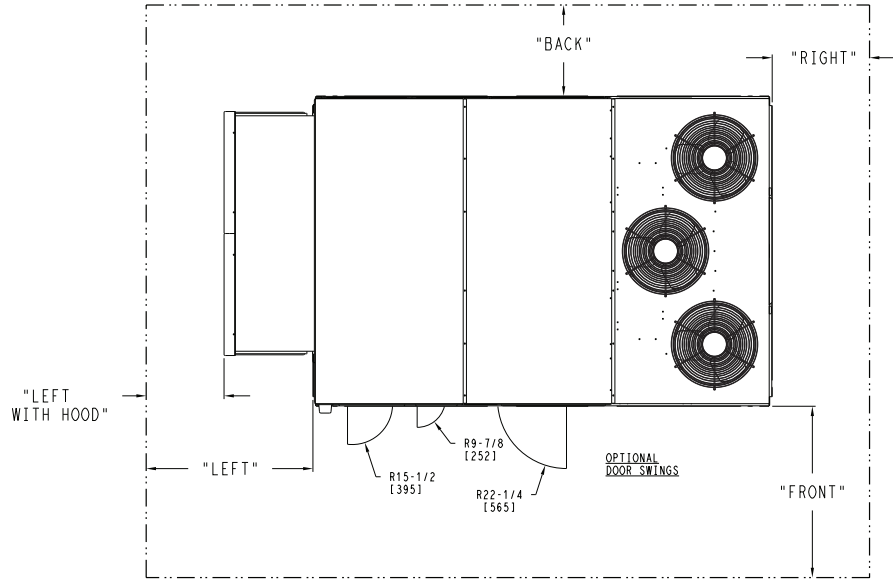
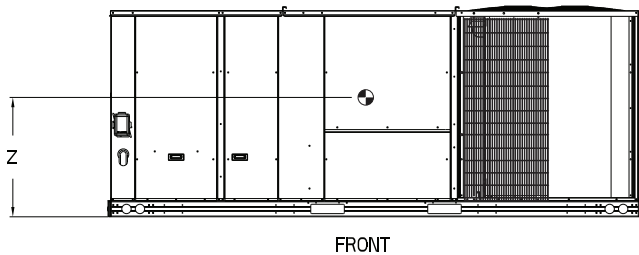
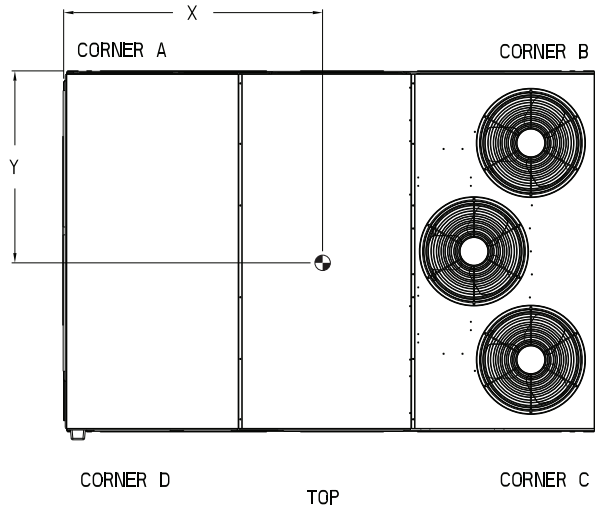

NOTES:

1. CLEARANCE ABOVE THE UNIT TO BE 72"
2. FOR ALL MINIMUM CLEARANCES LOCAL CODES OR JURISDICTIONS MAY PREVAIL.

SURFACE	CLEARANCE		OPERATING CLEARANCE
	SERVICE WITH CONDUCTIVE BARRIER	SERVICE WITH NONCONDUCTIVE BARRIER	
FRONT	48 [1219mm]	36 [914mm]	18 [457mm]
LEFT	48 [1219mm]	42 [1067mm]	18 [457mm]
BACK	42 [1067mm]	36 [914mm]	18 [457mm]
LEFT WITH HOOD	36 [914mm]	36 [914mm]	18 [457mm]
RIGHT	36 [914mm]	36 [914mm]	18 [457mm]
TOP	72 [1829mm]	72 [1829mm]	72 [1829mm]

ITC CLASSIFICATION U.S. ECCN:NSR	SHEET 4 OF 5	DATE 05/21/24	SUPERCEDES -	RAF 210 SINGLE ZONE ELECTRICAL COOLING WITH ELECTRIC HEAT	50HE004900	REV -
-------------------------------------	-----------------	------------------	-----------------	---	------------	----------

RAF210 Base Unit Dimensions (cont)



THIS DOCUMENT IS THE PROPERTY OF CARRIER CORPORATION AND IS DELIVERED UPON THE EXPRESS CONDITION THAT THE CONTENTS WILL NOT BE DISCLOSED OR USED WITHOUT WRITTEN CONSENT.

SUBMISSION OF THESE DRAWINGS OR DOCUMENTS DOES NOT CONSTITUTE PART PERFORMANCE OR ACCEPTANCE OF CONTRACT.

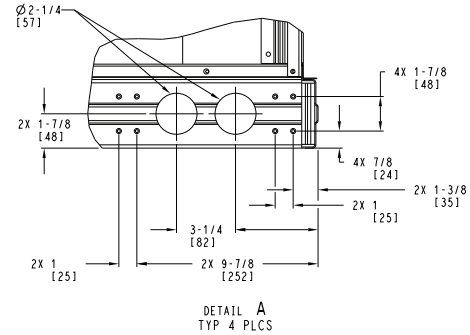
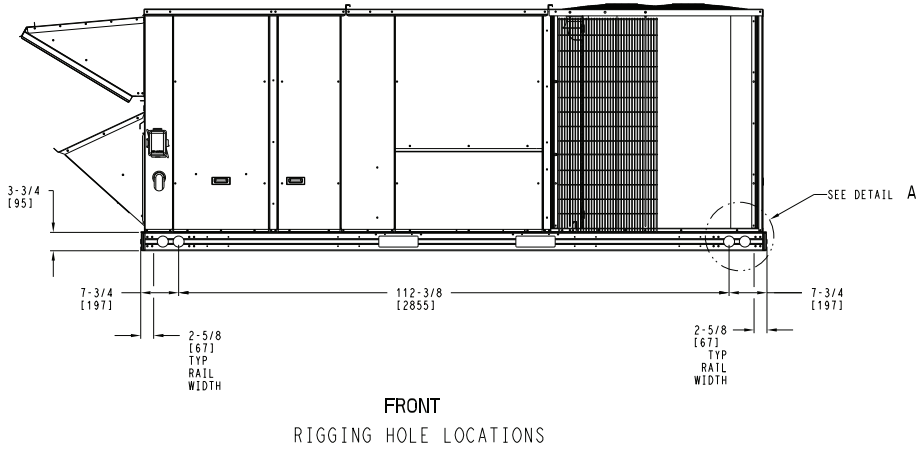
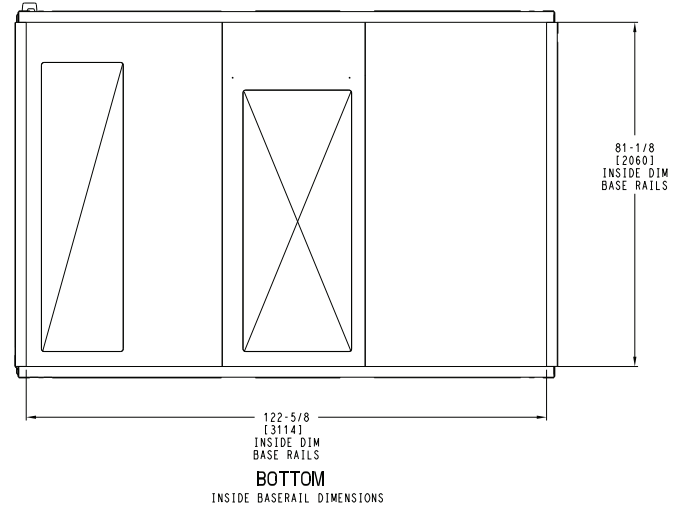
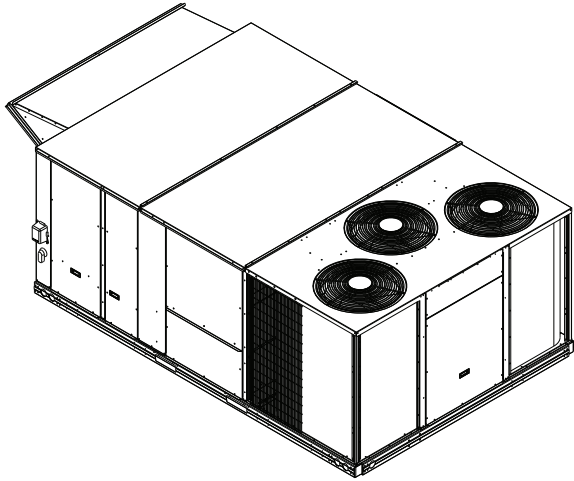

ITC CLASSIFICATION	SHEET	DATE	SUPERCEDES	RAF 210 SINGLE ZONE ELECTRICAL COOLING WITH ELECTRIC HEAT	50HE004900	REV
U.S. ECCN:NSR	5 OF 5	05/21/24	-			-

RAF240-300 Base Unit Dimensions



THIS DOCUMENT IS THE PROPERTY OF CARRIER CORPORATION AND IS DELIVERED UPON THE EXPRESS CONDITION THAT THE CONTENTS WILL NOT BE DISCLOSED OR USED WITHOUT WRITTEN CONSENT. SUBMISSION OF THESE DRAWINGS OR DOCUMENTS DOES NOT CONSTITUTE PART PERFORMANCE OR ACCEPTANCE OF CONTRACT.

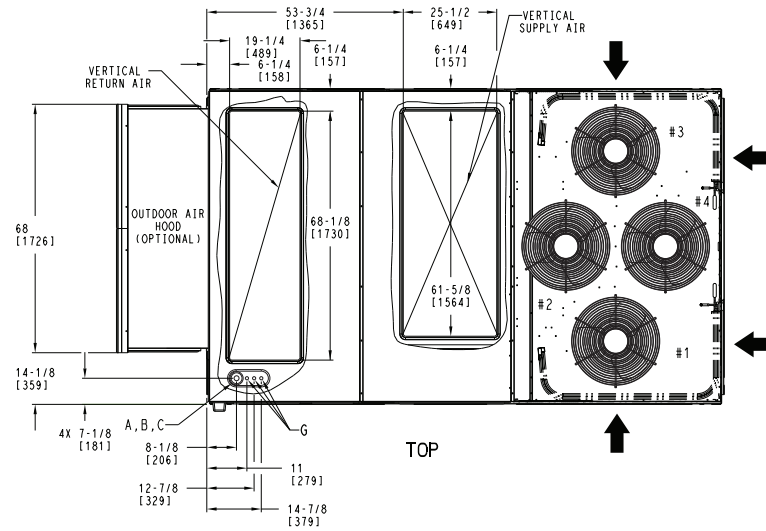
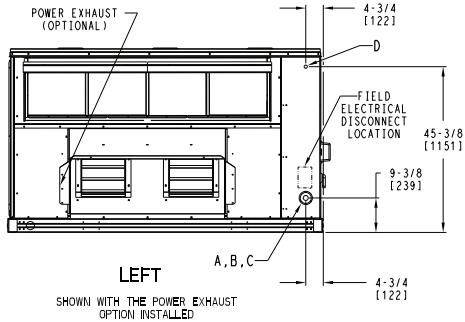
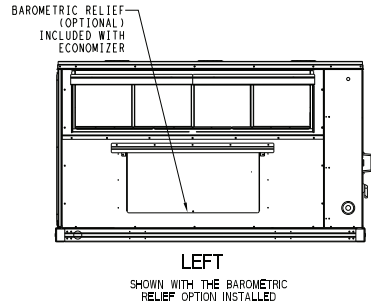
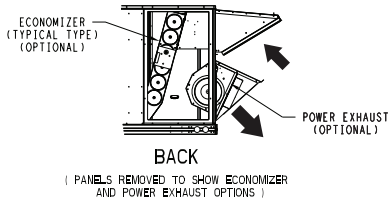

CONNECTION SIZES	
A	1 3/8" DIA [35] FIELD POWER SUPPLY KNOCKOUT
B	3" DIA [76] FIELD POWER SUPPLY KNOCKOUT
C	3 5/8" DIA [92] FIELD POWER SUPPLY KNOCKOUT
D	7/8" DIA [22] FIELD CONTROL WIRING HOLE
G	7/8" DIA [22] FIELD CONTROL WIRING KNOCKOUT

UNIT	H
24 SIZE	49-3/8 [1253]
28 SIZE	57-3/8 [1456]

- NOTES:
1. DIMENSIONS ARE IN INCHES. DIMENSIONS IN [] ARE IN MILLIMETERS.
 2. CENTER OF GRAVITY
 3. DIRECTION OF AIR FLOW
 4. ALL VIEW DRAWN USING 3RD ANGLE

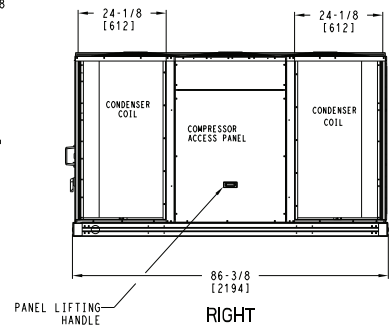
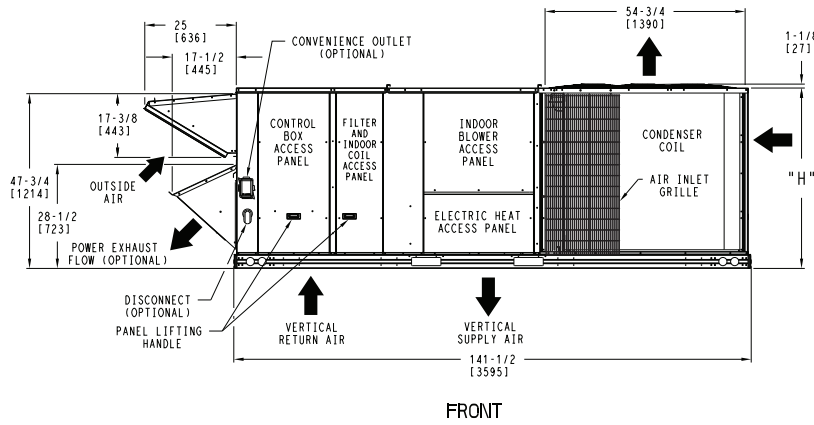

DEDICATED VERTICAL AIRFLOW UNIT
240, 300 SIZE

ITC CLASSIFICATION	SHEET	DATE	SUPERCEDES	RAF 240,300 SINGLE ZONE ELECTRICAL COOLING WITH ELECTRIC HEAT	50HE004902	REV
U.S. ECCN:NSR	1 OF 5	05/21/24	-			-

RAF240-300 Base Unit Dimensions (cont)

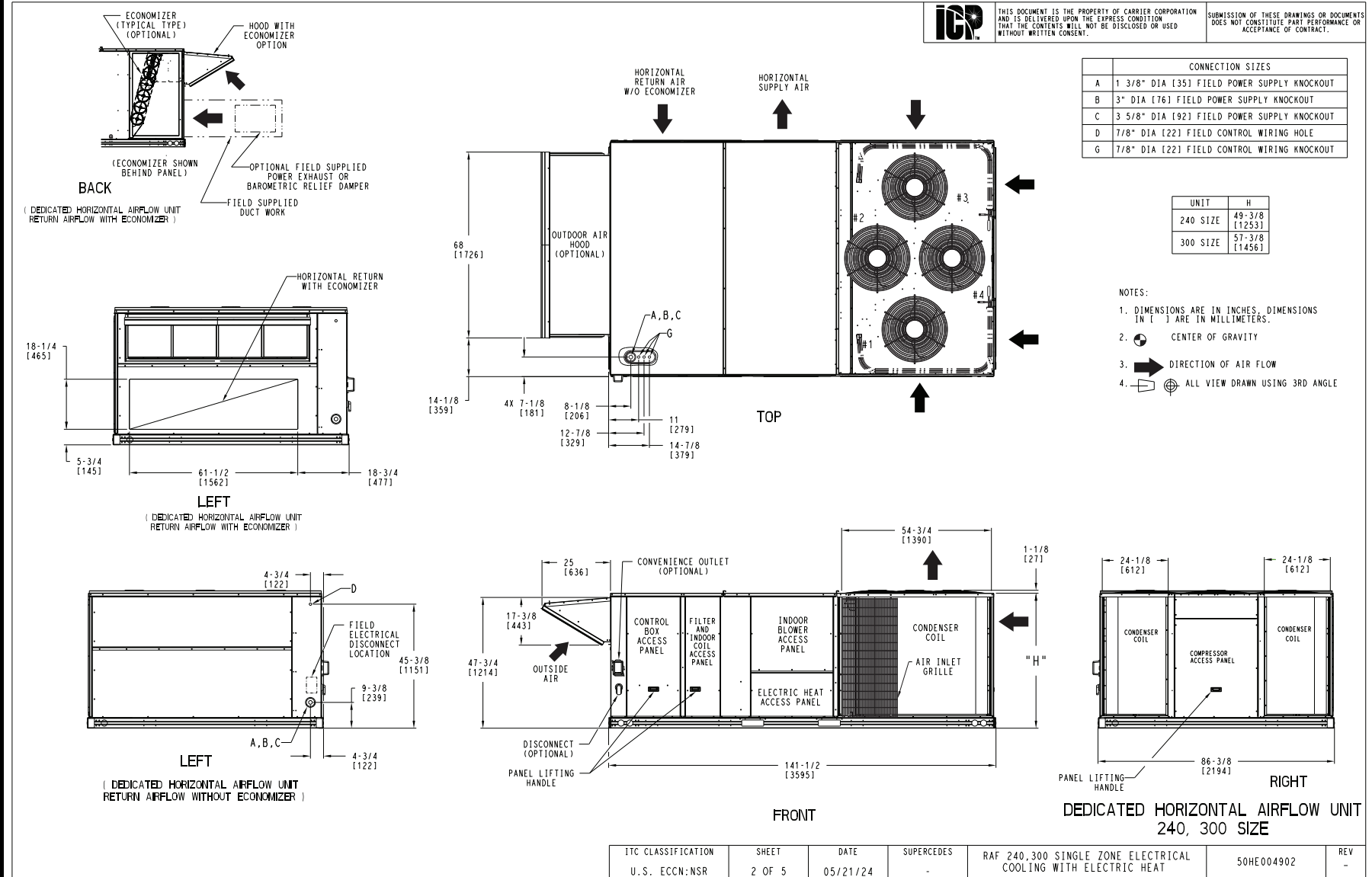

ITC CLASSIFICATION	SHEET	DATE	SUPERCEDES	RAF 240, 300 SINGLE ZONE ELECTRICAL COOLING WITH ELECTRIC HEAT	50HE004902	REV
U.S. ECCN:NSR	2 OF 5	05/21/24	-			-

RAF240-300 Base Unit Dimensions (cont)

CONNECTION SIZES	
E	3/4"-14 NPT CONDENSATE DRAIN



THIS DOCUMENT IS THE PROPERTY OF CARRIER CORPORATION AND IS DELIVERED UPON THE EXPRESS CONDITION THAT THE CONTENTS WILL NOT BE DISCLOSED OR USED WITHOUT WRITTEN CONSENT.

SUBMISSION OF THESE DRAWINGS OR DOCUMENTS DOES NOT CONSTITUTE PART PERFORMANCE OR ACCEPTANCE OF CONTRACT.

UNIT	G
240 SIZE	41-3/8 [1049]
300 SIZE	49-1/4 [1251]

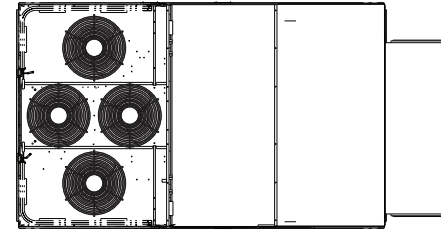
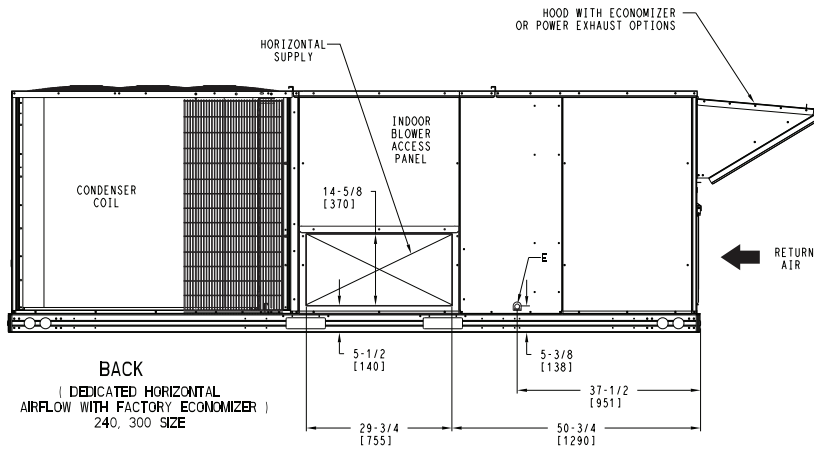
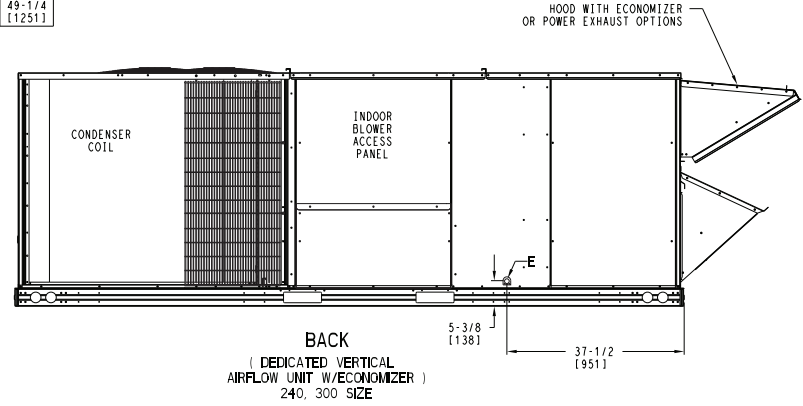
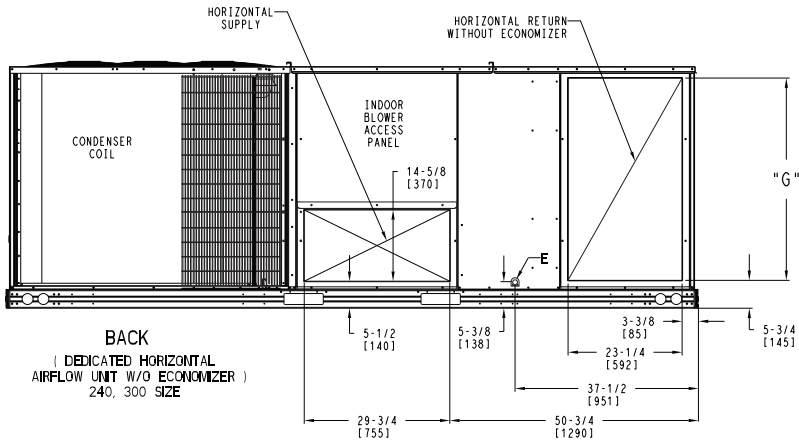

300 SIZE CONDENSER COIL TOP VIEW

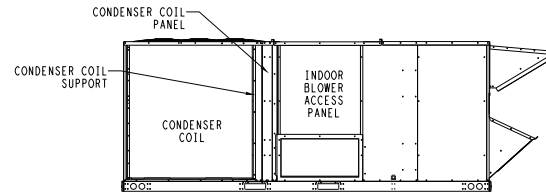

300 SIZE CONDENSER COIL END BRACKET SUPPORT

ITC CLASSIFICATION	SHEET	DATE	SUPERCEDES	RAF 240,300 SINGLE ZONE ELECTRICAL COOLING WITH ELECTRIC HEAT	50HE004902	REV
U.S. ECCN:NSR	3 OF 5	05/21/24	-			-

RAF240-300 Base Unit Dimensions (cont)

UNIT	STD. UNIT WEIGHT *		CORNER WEIGHT (A)		CORNER WEIGHT (B)		CORNER WEIGHT (C)		CORNER WEIGHT (D)		C.G.		
	LBS.	KG.	LBS.	KG.	LBS.	KG.	LBS.	KG.	LBS.	KG.	X	Y	Z
RAF 240	1873	850	402	182	473	215	539	244	458	208	76 1/2 [1943]	46 [1168]	16 1/2 [419]
RAF 300	2047	929	431	195	549	249	597	271	469	213	79 1/4 [2013]	45 [1143]	19 [483]



THIS DOCUMENT IS THE PROPERTY OF CARRIER CORPORATION AND IS DELIVERED UPON THE EXPRESS CONDITION THAT THE CONTENTS WILL NOT BE DISCLOSED OR USED WITHOUT WRITTEN CONSENT.

SUBMISSION OF THESE DRAWINGS OR DOCUMENTS DOES NOT CONSTITUTE PART PERFORMANCE OR ACCEPTANCE OF CONTRACT.

* STANDARD UNIT WEIGHT IS WITHOUT ELECTRIC HEAT AND WITHOUT PACKAGING. FOR OTHER OPTIONS AND ACCESSORIES, REFER TO THE PRODUCT DATA CATALOG.

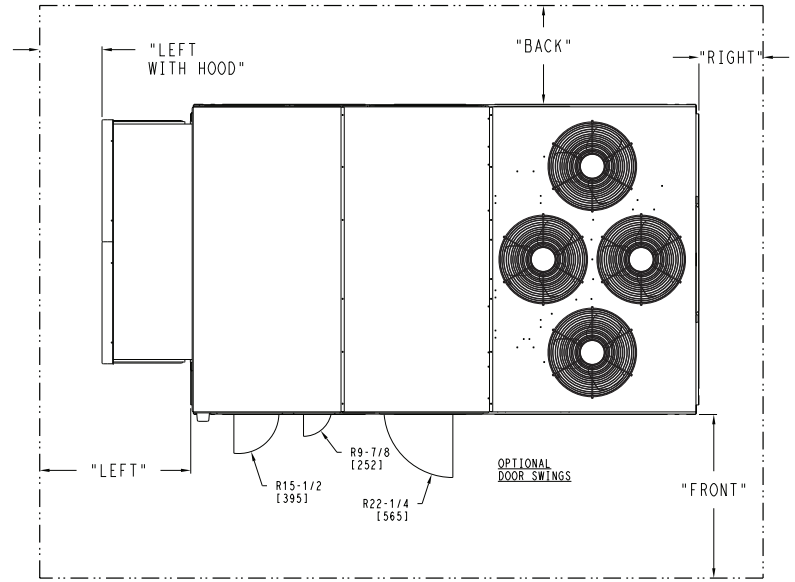
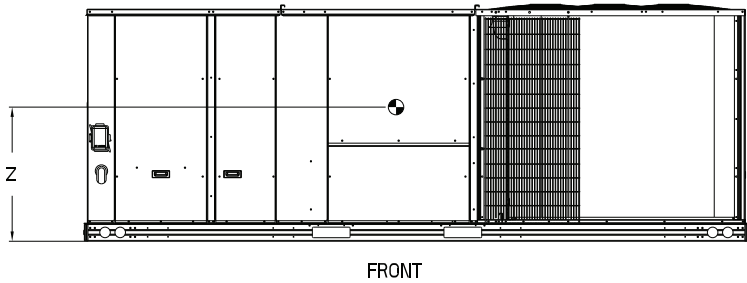
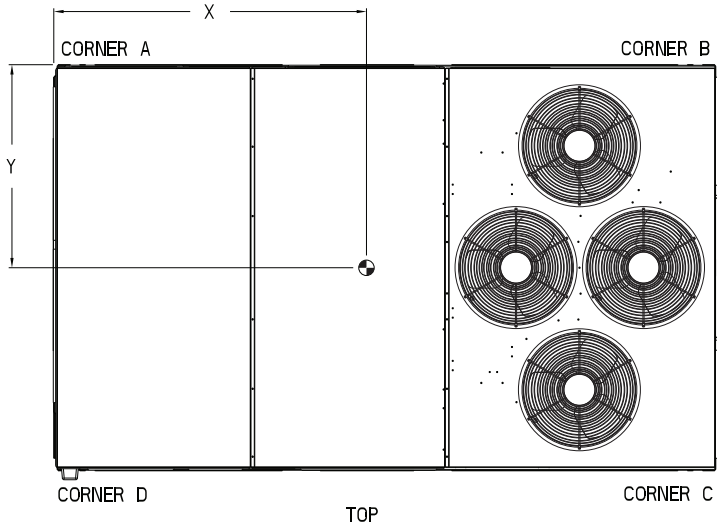

NOTES:

- CLEARANCE ABOVE THE UNIT TO BE 72"
- FOR ALL MINIMUM CLEARANCES LOCAL CODES OR JURISDICTIONS MAY PREVAIL.

SURFACE	CLEARANCE		
	SERVICE WITH CONDUCTIVE BARRIER	SERVICE WITH NONCONDUCTIVE BARRIER	OPERATING CLEARANCE
FRONT	48 [1219mm]	36 [914mm]	18 [457mm]
LEFT	48 [1219mm]	42 [1067mm]	18 [457mm]
BACK	42 [1067mm]	36 [914mm]	18 [457mm]
LEFT WITH HOOD	36 [914mm]	36 [914mm]	18 [457mm]
RIGHT	36 [914mm]	36 [914mm]	18 [457mm]
TOP	72 [1829mm]	72 [1829mm]	72 [1829mm]

ITC CLASSIFICATION	SHEET	DATE	SUPERCEDES	RAF 240, 300 SINGLE ZONE ELECTRICAL COOLING WITH ELECTRIC HEAT	REV
U.S. ECCN:NSR	4 OF 5	05/21/24	-		50HE004902

RAF240-300 Base Unit Dimensions (cont)



THIS DOCUMENT IS THE PROPERTY OF CARRIER CORPORATION AND IS DELIVERED UPON THE EXPRESS CONDITION THAT THE CONTENTS WILL NOT BE DISCLOSED OR USED WITHOUT WRITTEN CONSENT.

SUBMISSION OF THESE DRAWINGS OR DOCUMENTS DOES NOT CONSTITUTE PART PERFORMANCE OR ACCEPTANCE OF CONTRACT.

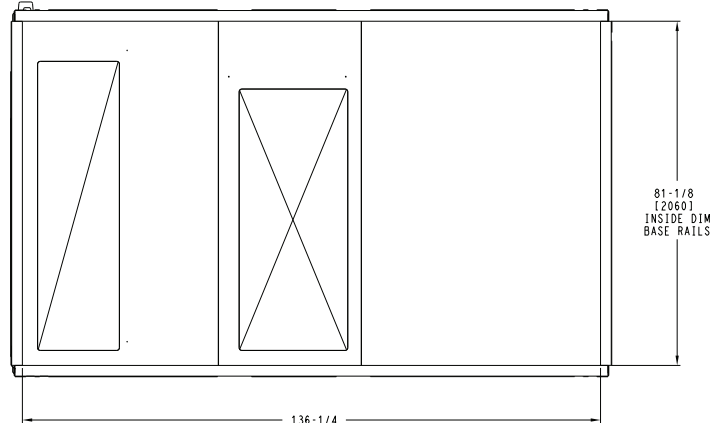
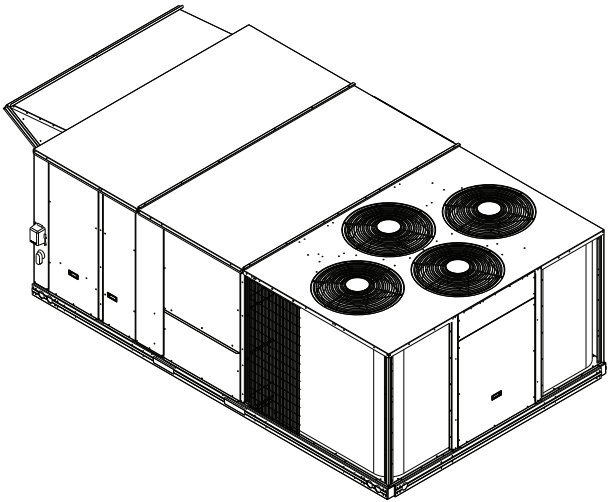

BOTTOM

INSIDE BASERAIL DIMENSIONS

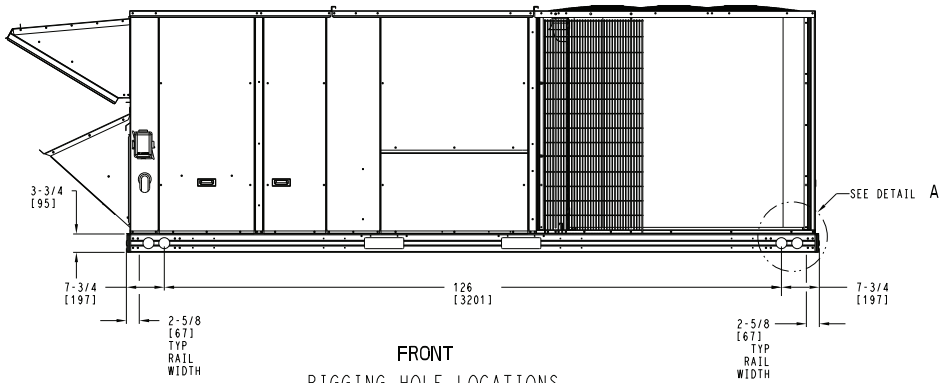

FRONT
RIGGING HOLE LOCATIONS

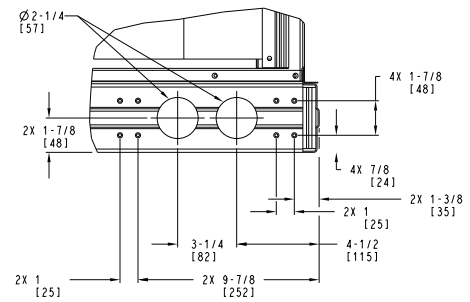

DETAIL A
TYP 4 PLCS

ITC CLASSIFICATION	SHEET	DATE	SUPERCEDES	RAF 240,300 SINGLE ZONE ELECTRICAL COOLING WITH ELECTRIC HEAT	50HE004902	REV
U.S. ECCN:NSR	5 OF 5	05/21/24	-			-

RAF336 Base Unit Dimensions

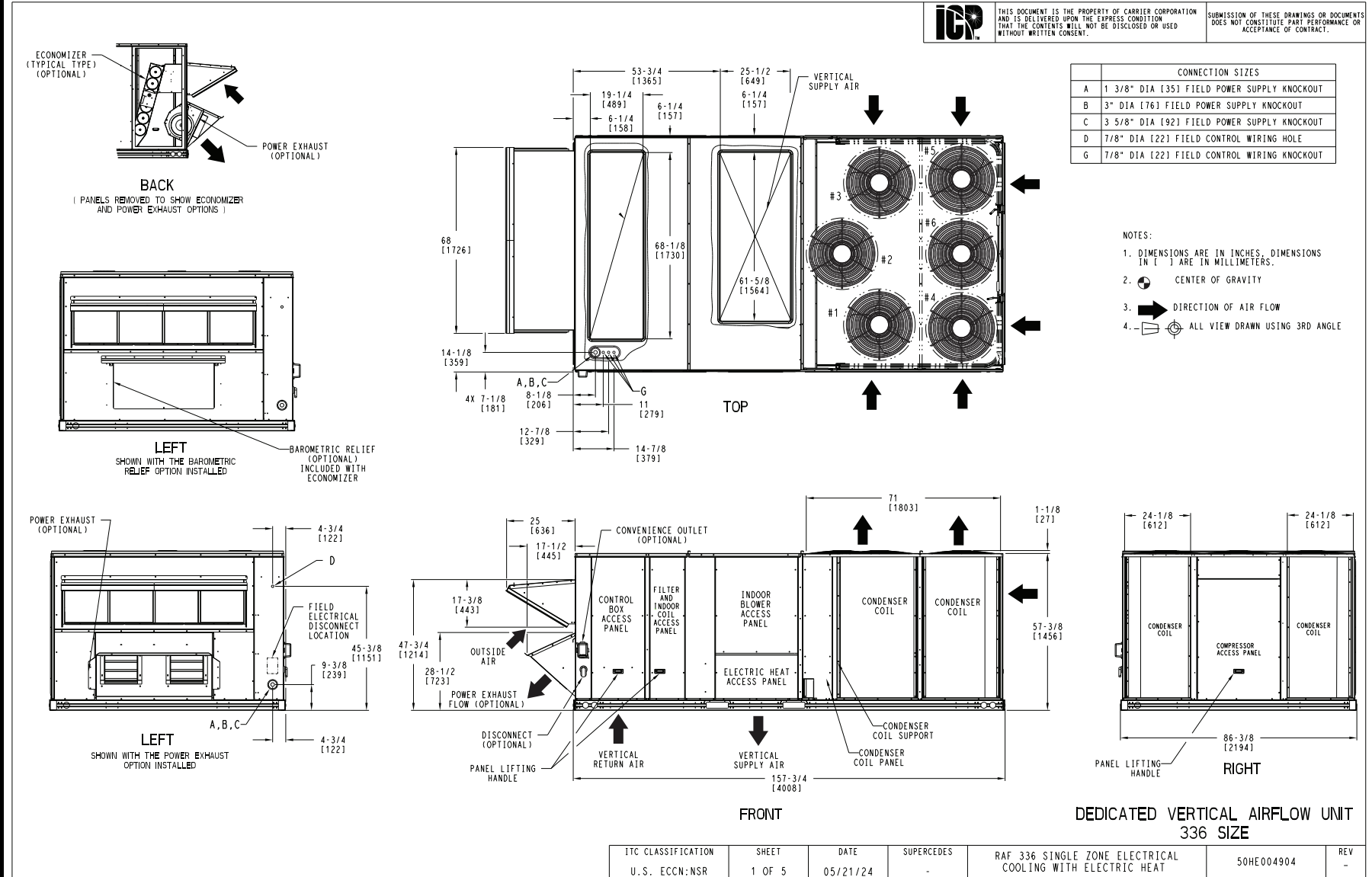

ITC CLASSIFICATION	SHEET	DATE	SUPERCEDES	RAF 336 SINGLE ZONE ELECTRICAL COOLING WITH ELECTRIC HEAT	50HE004904	REV
U.S. ECCN:NSR	1 OF 5	05/21/24	-			-

RAF336 Base Unit Dimensions (cont)

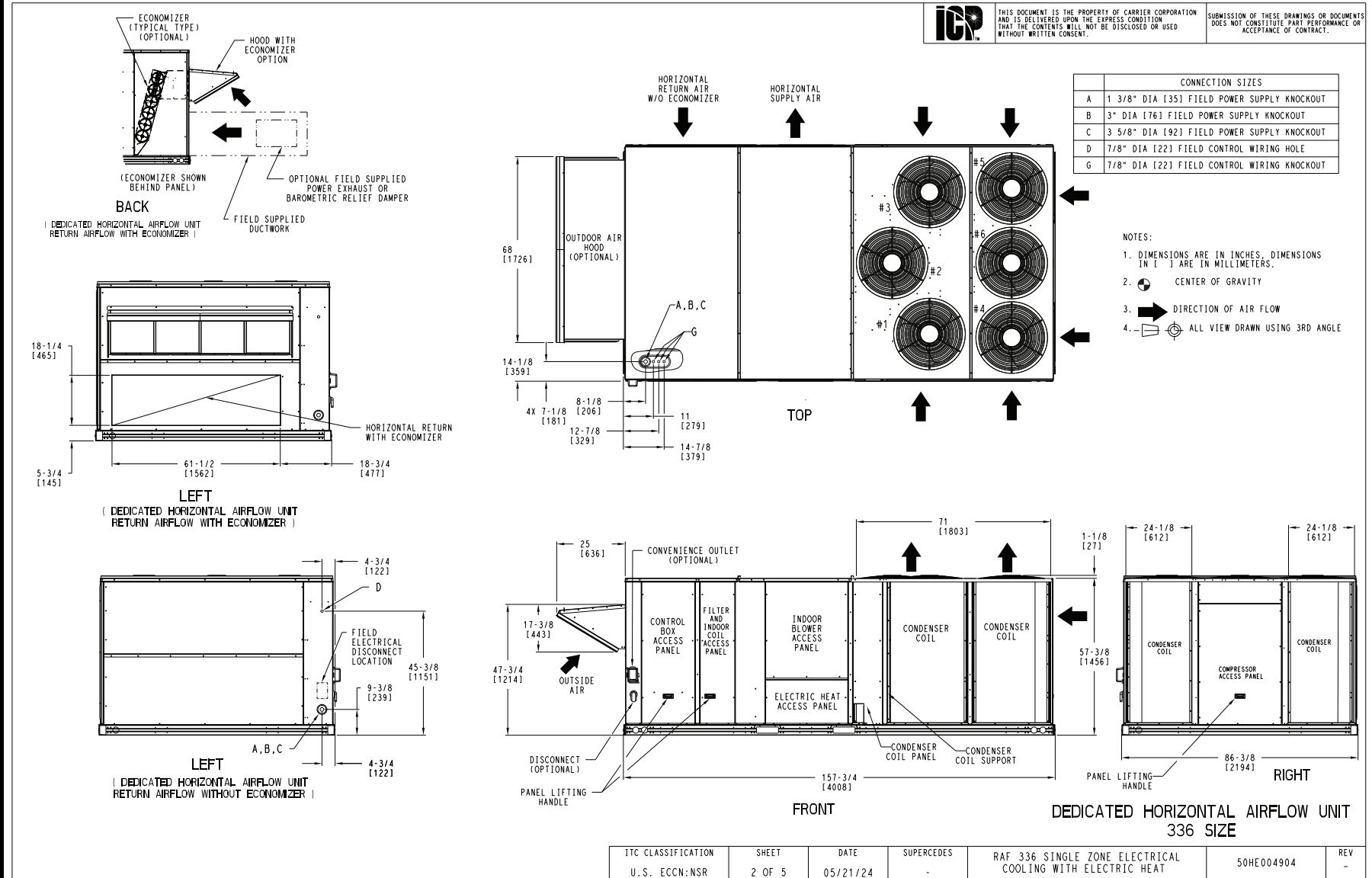

ITC CLASSIFICATION	SHEET	DATE	SUPERCEDES	RAF 336 SINGLE ZONE ELECTRICAL COOLING WITH ELECTRIC HEAT	50HE004904	REV
U.S. ECCN:NSR	2 OF 5	05/21/24	-			-

RAF336 Base Unit Dimensions (cont)

CONNECTION SIZES	
E	3/4"-14 NPT CONDENSATE DRAIN



THIS DOCUMENT IS THE PROPERTY OF CARRIER CORPORATION AND IS DELIVERED UPON THE EXPRESS CONDITION THAT THE CONTENTS WILL NOT BE DISCLOSED OR USED WITHOUT WRITTEN CONSENT.

SUBMISSION OF THESE DRAWINGS OR DOCUMENTS DOES NOT CONSTITUTE PART PERFORMANCE OR ACCEPTANCE OF CONTRACT.

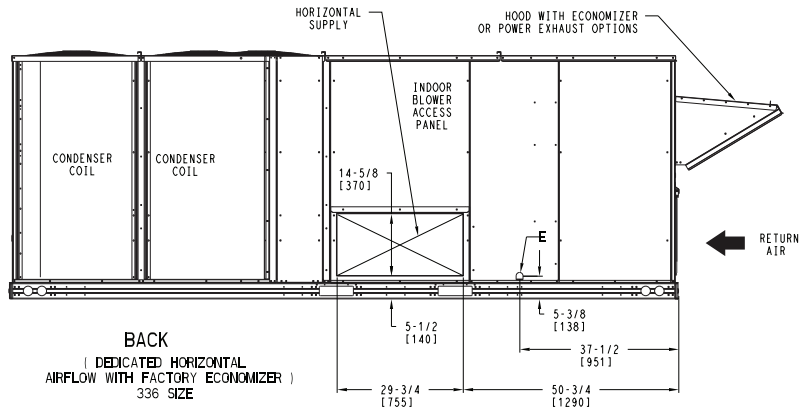
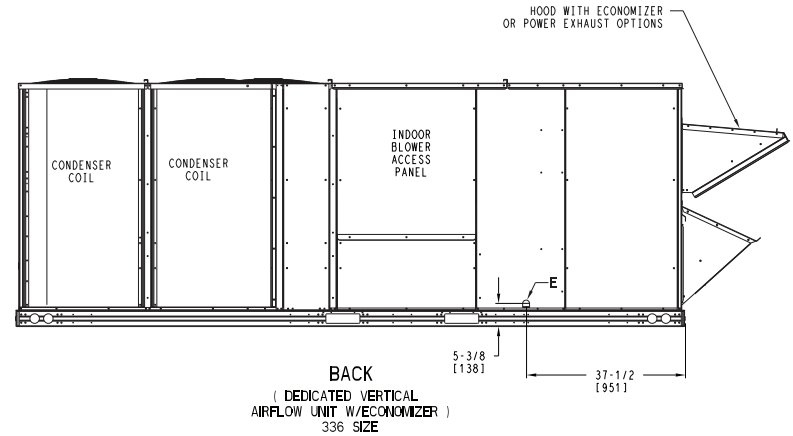
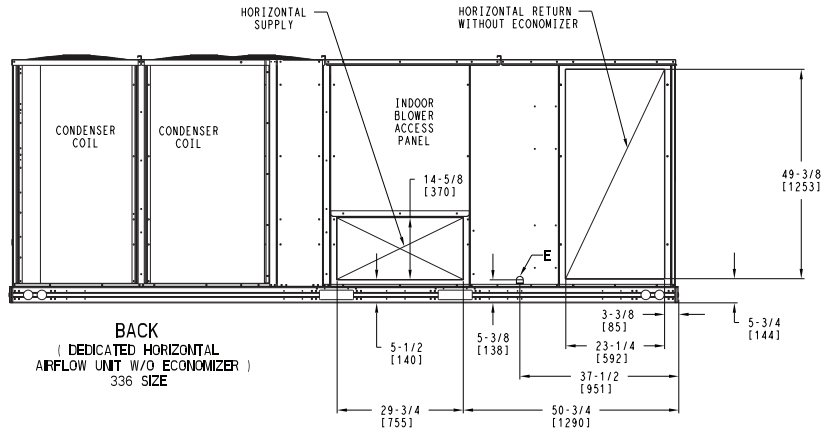

ITC CLASSIFICATION	SHEET	DATE	SUPERCEDES	RAF 336 SINGLE ZONE ELECTRICAL COOLING WITH ELECTRIC HEAT	50HE004904	REV
U.S. ECCN:NSR	3 OF 5	05/21/24	-			-

RAF336 Base Unit Dimensions (cont)

UNIT	STD UNIT WEIGHT *		CORNER WEIGHT (A)		CORNER WEIGHT (B)		CORNER WEIGHT (C)		CORNER WEIGHT (D)		C.G.					
	LBS.	KG.	LBS.	KG.	LBS.	KG.	LBS.	KG.	LBS.	KG.	X	Y	Z			
RAF 336	2224	1009	501	227	616	279	611	277	497	225	87	[2210]	43	[1092]	19	[483]



THIS DOCUMENT IS THE PROPERTY OF CARRIER CORPORATION AND IS DELIVERED UPON THE EXPRESS CONDITION THAT THE CONTENTS WILL NOT BE DISCLOSED OR USED WITHOUT WRITTEN CONSENT.

SUBMISSION OF THESE DRAWINGS OR DOCUMENTS DOES NOT CONSTITUTE PART PERFORMANCE OR ACCEPTANCE OF CONTRACT.

* STANDARD UNIT WEIGHT IS WITHOUT ELECTRIC HEAT AND WITHOUT PACKAGING. FOR OTHER OPTIONS AND ACCESSORIES, REFER TO THE PRODUCT DATA CATALOG.

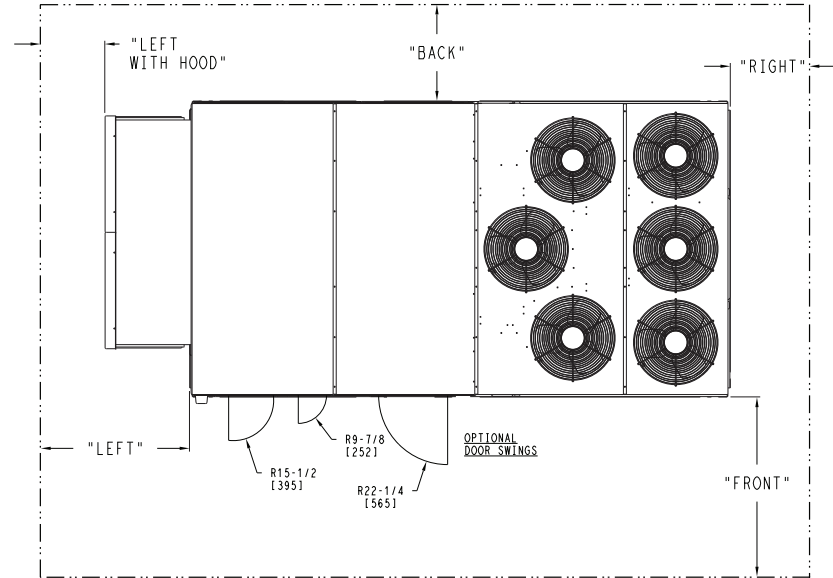
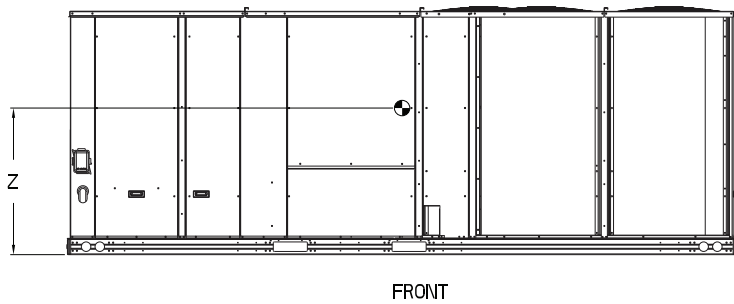
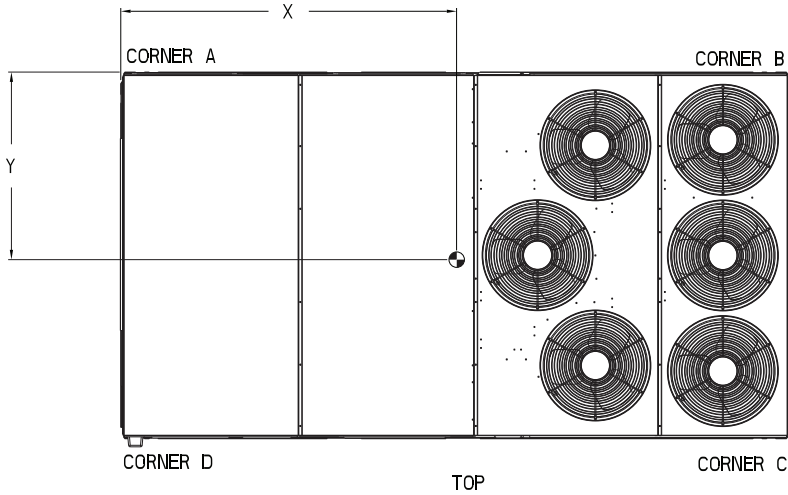

NOTES:

- CLEARANCE ABOVE THE UNIT TO BE 72"
- FOR ALL MINIMUM CLEARANCES LOCAL CODES OR JURISDICTIONS MAY PREVAIL.

SURFACE	CLEARANCE		OPERATING CLEARANCE
	SERVICE WITH CONDUCTIVE BARRIER	SERVICE WITH NONCONDUCTIVE BARRIER	
FRONT	48 [1219mm]	36 [914mm]	18 [457mm]
LEFT	48 [1219mm]	42 [1067mm]	18 [457mm]
BACK	42 [1067mm]	36 [914mm]	18 [457mm]
LEFT WITH HOOD	36 [914mm]	36 [914mm]	18 [457mm]
RIGHT	36 [914mm]	36 [914mm]	18 [457mm]
TOP	72 [1829mm]	72 [1829mm]	72 [1829mm]

ITC CLASSIFICATION U.S. ECCN:NSR	SHEET 4 OF 5	DATE 05/21/24	SUPERCEDES -	RAF 336 SINGLE ZONE ELECTRICAL COOLING WITH ELECTRIC HEAT	50HE004904	REV -
-------------------------------------	-----------------	------------------	-----------------	---	------------	----------

RAF336 Base Unit Dimensions (cont)



THIS DOCUMENT IS THE PROPERTY OF CARRIER CORPORATION AND IS DELIVERED UPON THE EXPRESS CONDITION THAT THE CONTENTS WILL NOT BE DISCLOSED OR USED WITHOUT WRITTEN CONSENT.

SUBMISSION OF THESE DRAWINGS OR DOCUMENTS DOES NOT CONSTITUTE PART PERFORMANCE OR ACCEPTANCE OF CONTRACT.

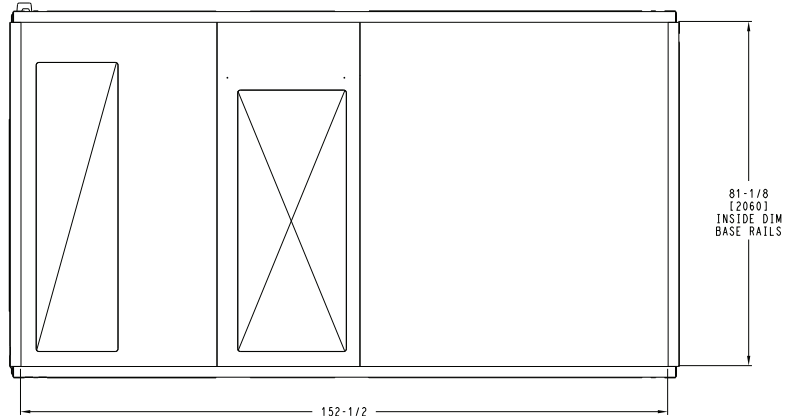
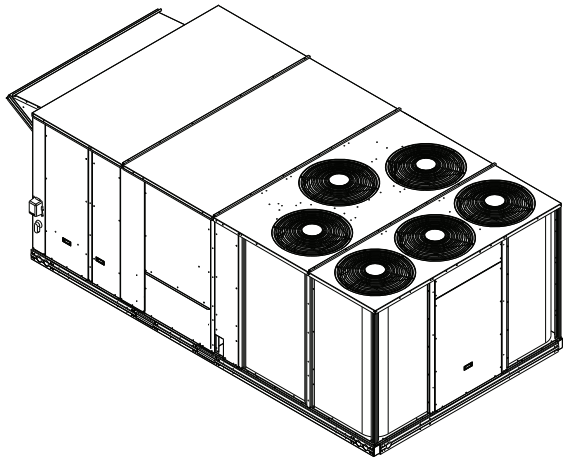

BOTTOM
INSIDE BASERAIL DIMENSIONS

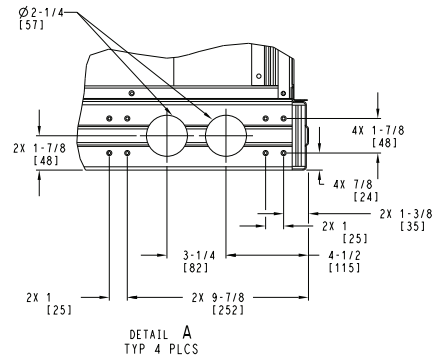
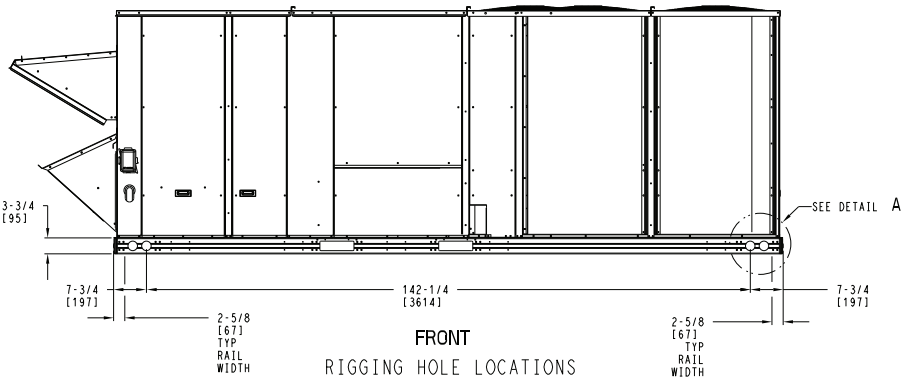

ITC CLASSIFICATION	SHEET	DATE	SUPERCEDES	RAF 336 SINGLE ZONE ELECTRICAL COOLING WITH ELECTRIC HEAT	50HE004904	REV
U.S. ECCN: NSR	5 OF 5	05/21/24	-			-

Accessory dimensions

Roof Curb Dimensions — RGF/RAF210

"A"	ROOF CURB ACCESSORY
1'-2" [356.0]	CRRFCURB045A00
2'-0" [610.0]	CRRFCURB046A00

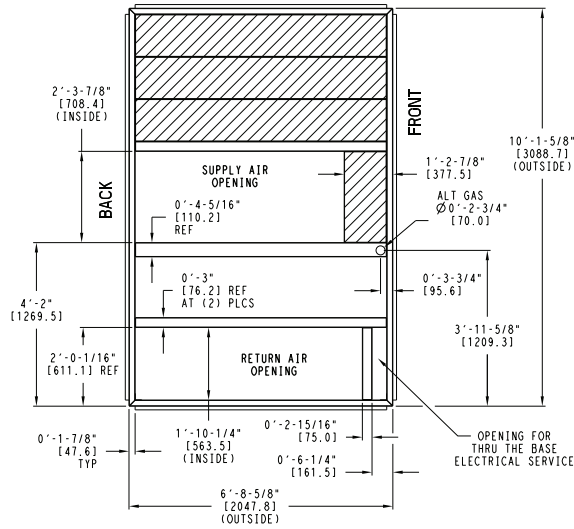

NOTES:

- 1 ROOF CURB ACCESSORY IS SHIPPED UNASSEMBLED.
- 2 DIMENSIONS IN [] ARE IN MILLIMETERS.
- 3 ROOF CURB GALVANIZED STEEL.
- 4 ATTACH DUCTWORK TO CURB (FLANGES ON DUCT REST ON CURB)
- 5 SERVICE CLEARANCE 4 FT ON EACH SIDE

➔ DIRECTION OF AIR FLOW

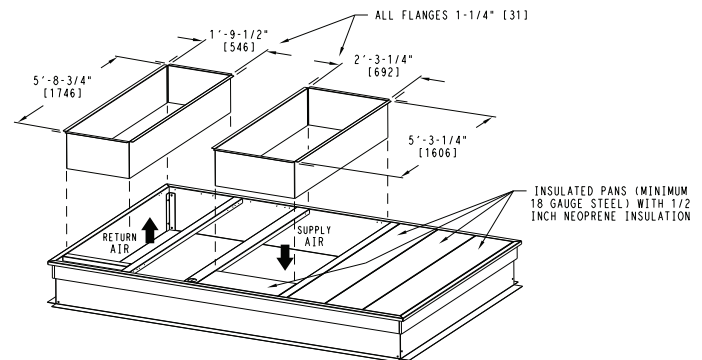
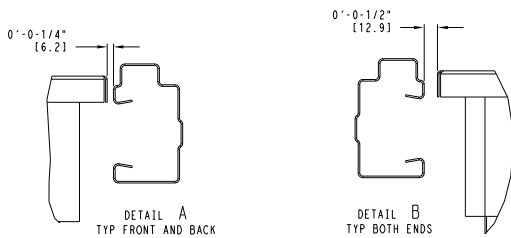
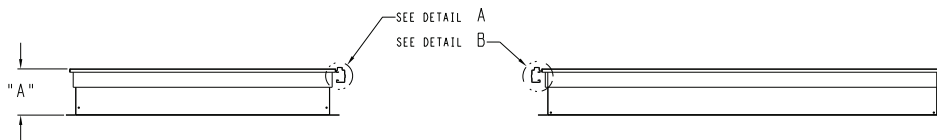
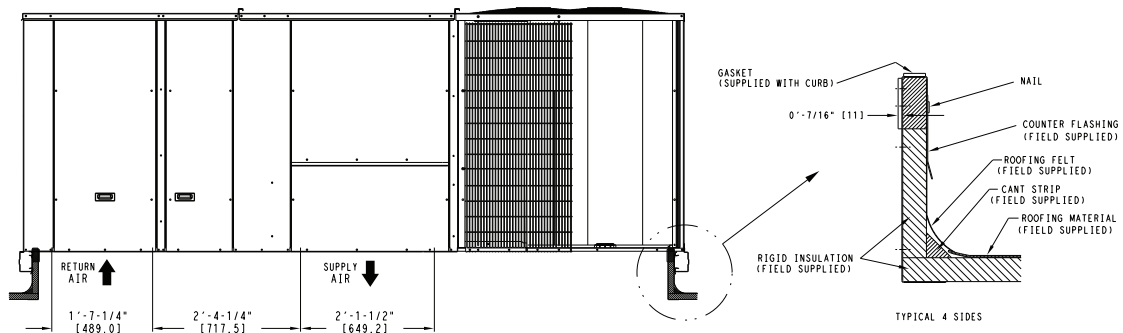
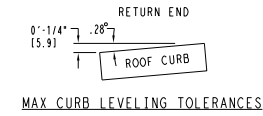
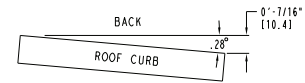

Accessory dimensions (cont)

Roof Curb Dimensions — RGF/RAF240-300

"A"	ROOF CURB ACCESSORY
1'-2" [356.0]	CRRFCURB047A00
2'-0" [610.0]	CRRFCURB048A00

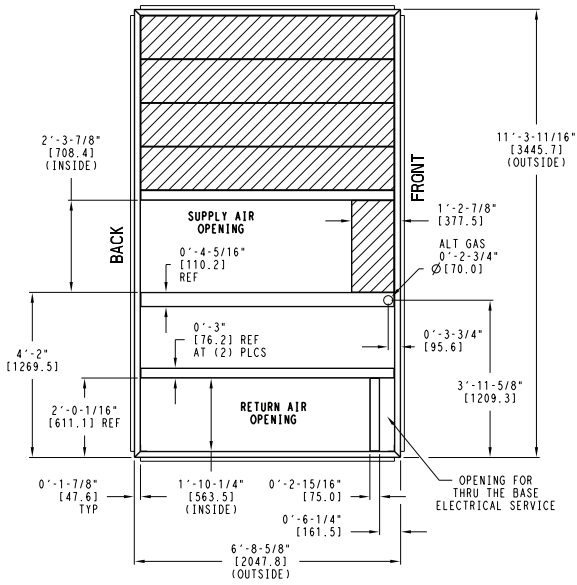

NOTES:

- 1 ROOF CURB ACCESSORY IS SHIPPED UNASSEMBLED.
- 2 DIMENSIONS IN [] ARE IN MILLIMETERS.
- 3 ROOF CURB GALVANIZED STEEL.
- 4 ATTACH DUCTWORK TO CURB (FLANGES ON DUCT REST ON CURB)
- 5 SERVICE CLEARANCE 4 ft ON EACH SIDE

➔ DIRECTION OF AIR FLOW

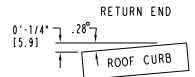
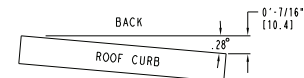

MAX CURB LEVELING TOLERANCES

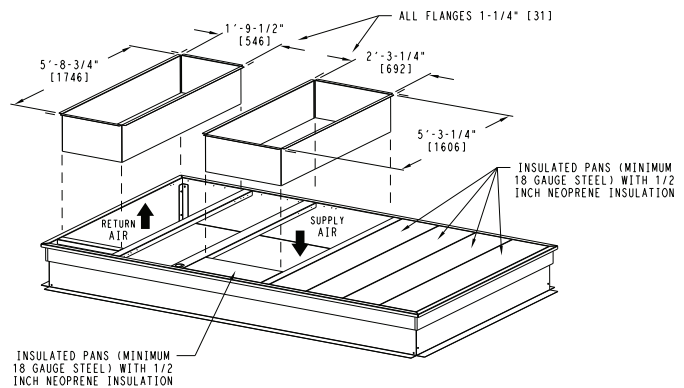
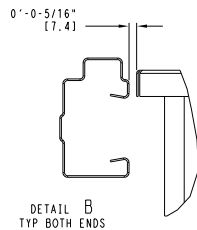
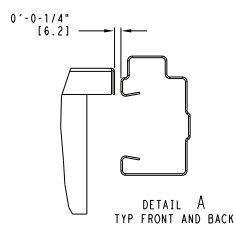
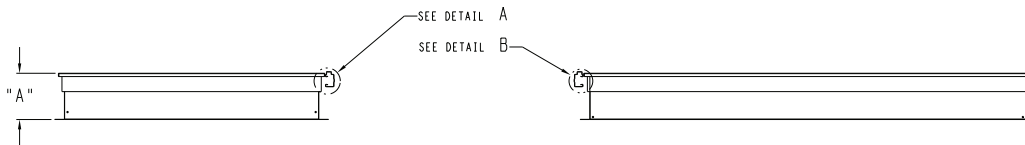
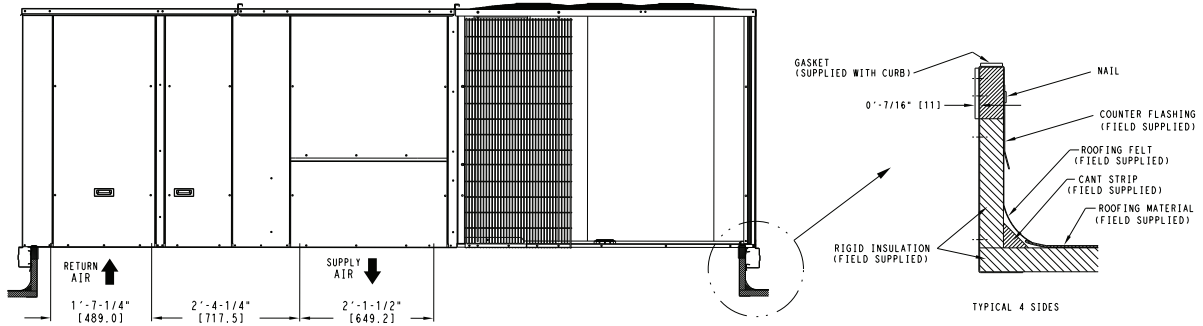

Accessory dimensions (cont)

Roof Curb Dimensions — RGF/RAF336

"A"	ROOF CURB ACCESSORY
1'-2" [356.0]	CRRFCURB049A00
2'-0" [610.0]	CRRFCURB050A00

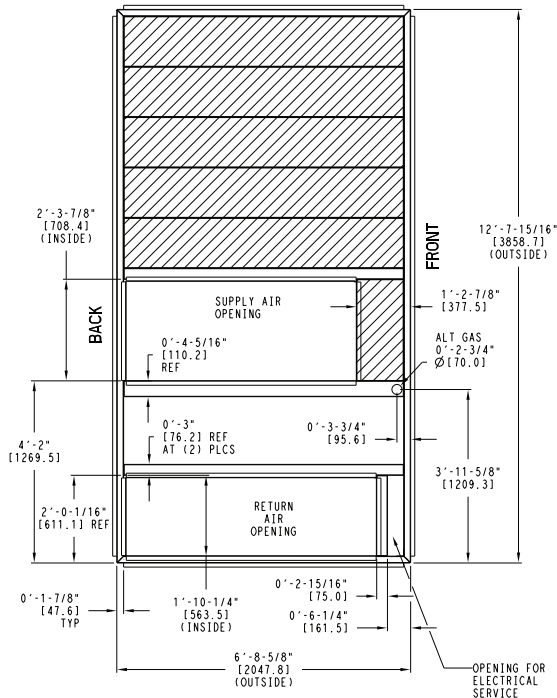

- NOTES:
- 1 ROOF CURB ACCESSORY IS SHIPPED UNASSEMBLED.
 - 2 BOLT HEADS TO BE ON INSIDE OF FLANGE. CLEARANCE IS [1] 0'-0-7/16" TYP ALL CORNERS.
 - 3 DIMENSIONS IN [] ARE IN MILLIMETERS.
 - 4 ROOF CURB GALVANIZED STEEL.
 - 5 ATTACH DUCTWORK TO CURB (FLANGES ON DUCT REST ON CURB)
 - 6 SERVICE CLEARANCE 4 FT ON EACH SIDE
- ➔ DIRECTION OF AIR FLOW

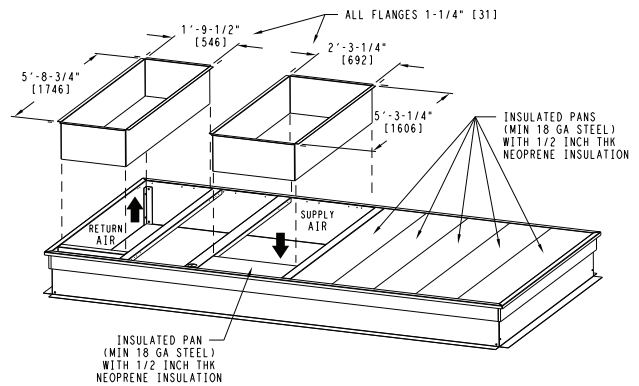
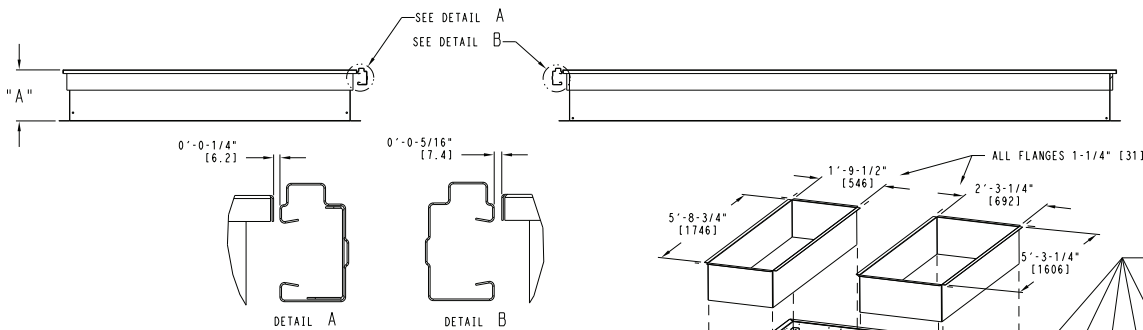
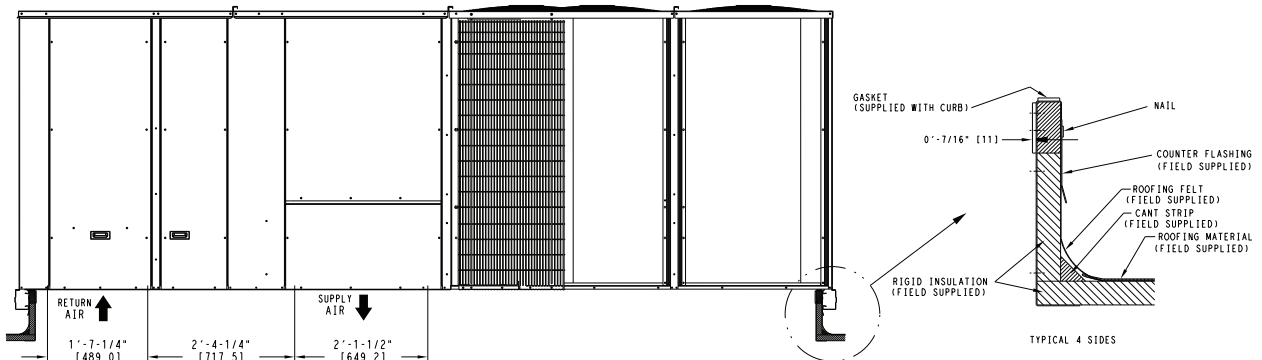
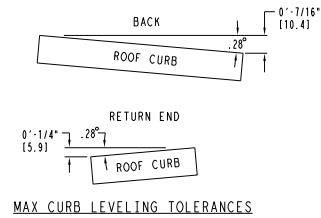

Performance data

RGF/RAF210 Two Stage Cooling Capacities

RGF/RAF210			AMBIENT TEMPERATURE (°F)																
			85			95			105			115			125				
			EA (db)			EA (db)			EA (db)			EA (db)			EA (db)				
			75	80	85	75	80	85	75	80	85	75	80	85	75	80	85		
5250 cfm	EA (wb)	58	TC	190.9	190.9	223.0	184.1	184.1	217.7	175.8	175.8	208.5	167.1	167.1	205.7	158.6	158.6	196.0	
			SHC	146.1	183.4	223.0	141.7	178.6	217.7	134.7	170.5	208.5	130.9	167.1	205.7	123.7	158.6	196.0	
		62	TC	205.3	205.3	205.3	194.0	194.0	198.4	182.3	182.3	191.8	173.6	173.6	189.9	162.6	162.6	192.0	
			SHC	132.7	172.9	216.1	125.7	166.1	209.7	119.5	159.9	203.5	114.2	154.9	199.1	108.3	149.4	193.8	
		67	TC	223.8	223.8	223.8	214.3	214.3	214.3	201.6	201.6	201.6	192.0	192.0	192.0	—	—	—	
			SHC	106.1	146.1	189.7	101.1	141.6	186.2	95.1	136.1	181.0	90.0	131.6	177.6	—	—	—	
	72	TC	246.7	246.7	246.7	236.2	236.2	236.2	222.3	222.3	222.3	212.1	212.1	212.1	—	—	—		
		SHC	81.1	120.1	163.3	75.8	115.5	159.5	69.5	109.6	154.7	64.2	105.2	151.4	—	—	—		
	76	TC	—	266.8	266.8	—	255.7	255.7	—	242.1	242.1	—	229.7	229.7	—	—	—		
		SHC	—	97.5	144.9	—	93.0	141.2	—	87.9	136.9	—	82.9	124.6	—	—	—		
	6150 cfm	EA (wb)	58	TC	203.9	203.9	240.0	194.6	194.6	237.8	185.6	185.6	227.5	177.2	177.2	217.8	168.1	168.1	207.2
				SHC	157.5	197.5	240.0	153.8	194.6	237.8	146.4	185.6	227.5	139.3	177.2	217.8	131.5	168.1	207.2
62			TC	210.6	210.6	223.9	200.1	200.1	221.3	190.8	190.8	222.9	179.5	179.5	219.3	172.3	172.3	202.6	
			SHC	140.5	186.4	235.8	134.5	180.5	230.4	129.6	175.8	225.9	123.1	169.2	219.3	113.6	156.2	202.6	
67			TC	231.5	231.5	231.5	221.4	221.4	221.4	210.5	210.5	210.5	197.9	197.9	197.9	—	—	—	
			SHC	112.6	159.3	210.2	107.5	154.7	206.5	102.2	149.7	202.3	96.2	144.3	197.5	—	—	—	
72		TC	254.7	254.7	254.7	243.7	243.7	243.7	232.1	232.1	232.1	218.2	218.2	218.2	—	—	—		
		SHC	83.1	128.6	179.3	77.7	123.8	175.6	72.2	119.0	171.8	66.1	113.3	167.2	—	—	—		
76		TC	—	271.6	271.6	—	263.3	263.3	—	251.0	251.0	—	236.1	236.1	—	—	—		
		SHC	—	102.2	155.5	—	98.1	142.9	—	93.4	143.2	—	87.7	140.2	—	—	—		
7000 cfm		EA (wb)	58	TC	211.5	211.5	258.0	202.2	202.2	247.2	194.2	194.2	237.7	185.3	185.3	227.4	175.6	175.6	216.1
				SHC	168.0	211.5	258.0	159.8	202.2	247.2	153.3	194.2	237.7	145.7	185.3	227.4	137.4	175.6	216.1
	62		TC	222.8	222.8	231.6	206.5	206.5	249.9	200.6	200.6	229.3	188.2	188.2	227.0	174.3	174.3	237.1	
			SHC	137.8	180.3	225.8	143.1	194.3	249.9	131.9	178.7	229.3	128.5	175.8	227.0	128.9	180.6	237.1	
	67		TC	236.6	236.6	236.6	226.7	226.7	226.7	215.4	215.4	215.4	202.1	202.1	202.1	—	—	—	
			SHC	117.8	170.5	228.5	113.1	166.4	225.3	107.6	161.4	221.2	101.6	155.8	216.2	—	—	—	
	72	TC	259.6	259.6	259.6	249.3	249.3	249.3	235.6	235.6	235.6	222.7	222.7	222.7	—	—	—		
		SHC	84.4	135.8	194.0	79.3	131.4	190.8	79.4	133.1	193.9	67.6	120.9	182.5	—	—	—		
	76	TC	—	278.8	278.8	—	269.2	269.2	—	256.3	256.3	—	240.6	240.6	—	—	—		
		SHC	—	106.8	166.1	—	102.7	159.5	—	97.7	156.7	—	91.9	152.7	—	—	—		
	7900 cfm	EA (wb)	58	TC	220.3	220.3	268.4	212.0	212.0	258.7	201.9	201.9	247.0	192.5	192.5	236.1	—	—	—
				SHC	175.2	220.3	268.4	168.1	212.0	258.7	159.6	201.9	247.0	151.6	192.5	236.1	—	—	—
62			TC	225.4	225.4	258.7	214.2	214.2	261.3	201.6	201.6	267.9	193.6	193.6	247.6	—	—	—	
			SHC	151.3	202.9	258.7	149.5	203.2	261.3	149.2	206.1	267.9	137.5	190.2	247.6	—	—	—	
67			TC	242.2	242.2	242.2	231.1	231.1	231.1	219.5	219.5	219.5	205.7	205.7	210.6	—	—	—	
			SHC	124.0	183.0	248.4	118.7	178.2	244.3	113.2	173.3	240.2	107.2	167.4	234.9	—	—	—	
72		TC	265.5	265.5	265.5	253.8	253.8	253.8	241.2	241.2	241.2	226.3	226.3	226.3	—	—	—		
		SHC	86.3	144.0	209.7	81.0	139.4	206.2	75.4	134.5	202.7	69.2	128.8	198.0	—	—	—		
76		TC	—	286.1	286.1	—	274.2	274.2	—	260.5	260.5	—	244.5	244.5	—	—	—		
		SHC	—	111.5	176.6	—	107.0	172.3	—	101.9	169.0	—	96.0	164.9	—	—	—		
8750 cfm		EA (wb)	58	TC	227.4	227.4	277.0	218.7	218.7	266.8	209.4	209.4	256.0	198.4	198.4	243.2	—	—	—
				SHC	180.8	227.4	277.0	173.4	218.7	266.8	165.5	209.4	256.0	156.3	198.4	243.2	—	—	—
	62		TC	224.5	224.5	297.9	217.8	217.8	287.2	209.6	209.6	269.0	200.8	200.8	248.2	—	—	—	
			SHC	171.8	235.2	304.3	161.8	221.9	287.2	152.6	209.3	270.7	138.9	191.4	248.2	—	—	—	
	67		TC	246.0	246.0	246.0	234.5	234.5	235.5	222.6	222.6	231.0	208.5	208.5	227.7	—	—	—	
			SHC	129.1	194.1	266.3	123.8	189.3	262.1	118.0	183.7	257.2	111.7	177.6	251.5	—	—	—	
	72	TC	273.9	273.9	273.9	257.1	257.1	257.1	244.2	244.2	244.2	229.1	229.1	229.1	—	—	—		
		SHC	88.0	153.2	228.5	82.2	146.6	220.9	76.6	141.6	217.1	70.4	135.9	212.4	—	—	—		
	76	TC	—	293.2	293.2	—	277.3	277.3	—	260.1	260.1	—	247.3	247.3	—	—	—		
		SHC	—	116.2	186.3	—	110.9	183.8	—	104.5	179.0	—	99.9	176.5	—	—	—		

LEGEND

—	Do Not Operate
cfm	Cubic Feet Per Minute (Supply Air)
EA (db)	Entering Air Temperature (dry bulb)
EA (wb)	Entering Air Temperature (wet bulb)
SHC	Sensible Heat Capacity (1000 Btuh) Gross
TC	Total Capacity (1000 Btuh) Gross

NOTE: See minimum-maximum airflow ratings on page 7.

Performance data (cont)

RGF/RAF210 Single Stage Cooling Capacities

RGF/RAF210			AMBIENT TEMPERATURE (°F)																
			85			95			105			115			125				
			EA (db)			EA (db)			EA (db)			EA (db)			EA (db)				
			75	80	85	75	80	85	75	80	85	75	80	85	75	80	85		
3150 cfm	EA (wb)	58	TC	104.3	104.3	125.1	96.9	96.9	116.8	89.5	89.5	108.6	81.7	81.7	100.1	74.2	74.2	91.6	
			SHC	84.1	104.3	125.1	77.5	96.9	116.8	70.9	89.5	108.6	64.2	81.7	100.1	57.4	74.2	91.6	
		62	TC	110.9	110.9	115.5	102.0	102.0	112.0	93.3	93.3	107.2	84.7	84.7	101.2	73.5	73.5	100.8	
			SHC	74.1	96.3	119.5	68.3	90.4	113.3	62.7	84.4	107.2	57.0	78.5	101.2	54.1	77.1	101.6	
		67	TC	125.0	125.0	125.0	115.9	115.9	115.9	106.7	106.7	106.7	97.1	97.1	97.1	87.5	87.5	87.5	
			SHC	58.5	80.7	103.9	52.9	74.8	97.8	47.3	68.8	91.7	41.7	63.0	85.6	36.2	57.1	79.7	
	72	TC	140.5	140.5	140.5	130.7	130.7	130.7	121.0	121.0	121.0	111.2	111.2	111.2	101.0	101.0	101.0		
		SHC	43.0	65.0	88.3	37.4	59.0	82.0	32.0	53.1	76.1	26.7	47.3	70.0	21.3	41.4	63.8		
	76	TC	—	153.3	153.3	—	143.5	143.5	—	133.8	133.8	—	123.4	123.4	—	112.6	112.6		
		SHC	—	52.0	75.5	—	46.2	69.5	—	40.5	63.6	—	34.8	57.4	—	28.9	51.2		
	3700 cfm	EA (wb)	58	TC	112.2	112.2	134.2	104.6	104.6	125.7	96.7	96.7	116.9	88.6	88.6	108.0	80.6	80.6	99.0
				SHC	90.9	112.2	134.2	84.2	104.6	125.7	77.1	96.7	116.9	70.0	88.6	108.0	63.0	80.6	99.0
62			TC	115.6	115.6	134.7	106.7	106.7	128.2	97.9	97.9	121.7	88.5	88.5	116.9	80.7	80.7	105.3	
			SHC	81.9	107.8	134.7	76.1	101.5	128.2	70.2	95.3	121.7	65.3	90.4	116.9	57.3	80.7	105.3	
67			TC	130.0	130.0	130.0	120.3	120.3	120.3	110.6	110.6	110.6	100.6	100.6	100.6	90.8	90.8	90.8	
			SHC	63.7	89.6	116.7	58.1	83.5	110.4	52.2	77.5	104.2	46.4	71.3	97.9	40.9	65.4	91.8	
72		TC	145.4	145.4	145.4	135.3	135.3	135.3	125.2	125.2	125.2	114.7	114.7	114.7	104.4	104.4	104.4		
		SHC	45.2	70.7	97.9	39.6	64.7	91.6	34.1	58.7	85.5	28.6	52.6	79.4	23.3	46.8	73.1		
76		TC	—	158.7	158.7	—	148.4	148.4	—	137.6	137.6	—	127.0	127.0	—	—	—		
		SHC	—	55.5	82.9	—	49.6	76.8	—	43.5	70.5	—	37.7	64.2	—	—	—		
4200 cfm		EA (wb)	58	TC	118.7	118.7	141.8	110.4	110.4	132.6	102.2	102.2	123.4	93.9	93.9	114.2	85.5	85.5	104.7
				SHC	96.3	118.7	141.8	89.0	110.4	132.6	81.8	102.2	123.4	74.5	93.9	114.2	67.0	85.5	104.7
	62		TC	119.6	119.6	147.6	111.3	111.3	139.7	100.8	100.8	138.0	94.1	94.1	121.2	85.6	85.6	111.5	
			SHC	88.4	117.4	147.6	82.6	110.5	139.7	78.5	107.5	138.0	68.2	94.1	121.2	61.2	85.6	111.5	
	67		TC	133.3	133.3	133.3	123.2	123.2	123.2	113.4	113.4	113.4	103.3	103.3	103.3	92.6	92.6	98.3	
			SHC	68.0	97.3	128.2	62.1	91.1	121.7	56.4	85.0	115.5	50.5	78.8	109.2	44.7	72.7	102.8	
	72	TC	148.9	148.9	148.9	138.6	138.6	138.6	128.2	128.2	128.2	117.4	117.4	117.4	106.8	106.8	106.8		
		SHC	46.9	75.7	106.9	41.2	69.7	100.5	35.7	63.6	94.2	30.1	57.6	87.8	24.7	51.5	81.7		
	76	TC	—	162.3	162.3	—	151.6	151.6	—	—	—	—	—	—	—	—	—		
		SHC	—	58.4	89.6	—	52.3	83.4	—	—	—	—	—	—	—	—	—		
	4750 cfm	EA (wb)	58	TC	124.7	124.7	148.4	115.9	115.9	138.8	107.5	107.5	129.5	98.7	98.7	119.6	90.0	90.0	109.8
				SHC	101.4	124.7	148.4	93.7	115.9	138.8	86.3	107.5	129.5	78.5	98.7	119.6	70.9	90.0	109.8
62			TC	124.7	124.7	156.7	117.5	117.5	141.1	107.6	107.6	137.1	98.9	98.9	127.0	90.2	90.2	116.7	
			SHC	93.9	124.7	156.7	84.2	112.0	141.1	79.5	107.6	137.1	72.2	98.9	127.0	64.7	90.2	116.7	
67			TC	135.9	135.9	135.9	126.0	126.0	126.0	115.9	115.9	119.6	105.4	105.4	117.6	95.2	95.2	114.4	
			SHC	72.4	105.3	139.9	66.5	99.2	133.6	60.7	92.9	127.2	54.9	86.7	120.7	49.1	80.4	114.4	
72		TC	152.0	152.0	152.0	141.4	141.4	141.4	130.6	130.6	130.6	120.6	120.6	120.6	108.9	108.9	108.9		
		SHC	48.7	81.0	115.9	43.0	74.9	109.5	37.4	68.8	103.1	32.0	62.9	97.1	26.4	56.5	90.6		
76		TC	—	165.0	165.0	—	—	—	—	—	—	—	—	—	—	—	—		
		SHC	—	61.3	96.2	—	—	—	—	—	—	—	—	—	—	—	—		
5250 cfm		EA (wb)	58	TC	128.8	128.8	153.5	120.4	120.4	143.9	111.6	111.6	134.2	102.5	102.5	124.1	93.2	93.2	113.6
				SHC	105.0	128.8	153.5	97.4	120.4	143.9	89.7	111.6	134.2	81.7	102.5	124.1	73.5	93.2	113.6
	62		TC	129.7	129.7	162.9	120.5	120.5	152.3	111.7	111.7	142.2	102.7	102.7	131.7	93.3	93.3	120.7	
			SHC	97.8	129.7	162.9	90.1	120.5	152.3	82.7	111.7	142.2	75.1	102.7	131.7	67.2	93.3	120.7	
	67		TC	138.0	138.0	140.5	128.0	128.0	138.0	117.8	117.8	136.2	107.2	107.2	131.1	96.3	96.3	124.4	
			SHC	76.3	112.4	150.7	70.4	106.2	144.2	64.5	99.9	137.8	58.5	93.5	131.1	52.6	87.0	124.4	
	72	TC	154.1	154.1	154.1	143.3	143.3	143.3	132.3	132.3	132.3	121.9	121.9	121.9	110.4	110.4	110.4		
		SHC	50.0	85.7	124.2	44.3	79.5	117.9	38.6	73.4	111.6	33.2	67.4	105.4	27.6	61.1	98.9		
	76	TC	—	—	—	—	—	—	—	—	—	—	—	—	—	—	—		
		SHC	—	—	—	—	—	—	—	—	—	—	—	—	—	—	—		

LEGEND

—	Do Not Operate
cfm	Cubic Feet Per Minute (Supply Air)
EA (db)	Entering Air Temperature (dry bulb)
EA (wb)	Entering Air Temperature (wet bulb)
SHC	Sensible Heat Capacity (1000 Btuh) Gross
TC	Total Capacity (1000 Btuh) Gross

NOTE: See minimum-maximum airflow ratings on page 7.

Performance data (cont)

RGF/RAF210**4/7/M/N — Unit with Hot Gas Re-Heat System in Subcooling Mode — Cooling Capacities

TEMP (°F) AIR ENTERING CONDENSER (Edb)		AIR ENTERING EVAPORATOR — SCFM/BF (80°F db)								
		5250/0.13			7000 /0.16			8750/0.19		
		Air Entering Evaporator — Ewb (°F)								
		72	67	62	72	67	62	72	67	62
75	TC	201.0	168.0	203.0	208.0	196.0	224.0	226.0	205.0	233.0
	SHC	113.0	126.0	68.0	128.0	169.0	89.0	157.0	194.0	101.0
	kW	16.6	15.8	18.2	16.5	16.7	18.9	17.2	16.9	19.1
85	TC	174.0	167.0	195.0	202.0	169.0	207.0	210.0	189.0	214.0
	SHC	87.0	126.0	61.0	123.0	142.0	73.0	141.0	179.0	83.0
	kW	17.5	17.7	20.1	18.4	17.5	20.4	18.6	18.2	20.5
95	TC	174.0	154.0	180.0	186.0	166.0	191.0	194.0	174.0	198.0
	SHC	88.0	114.0	47.0	108.0	141.0	59.0	126.0	165.0	69.0
	kW	19.7	19.3	21.9	20.0	19.6	22.2	20.2	19.8	22.4
105	TC	159.0	140.0	164.0	170.0	152.0	174.0	177.0	159.0	181.0
	SHC	74.0	101.0	33.0	93.0	127.0	43.0	111.0	151.0	53.0
	kW	21.4	21.0	23.8	21.7	21.3	24.0	21.9	21.5	24.2
115	TC	144.0	126.0	147.0	154.0	136.0	157.0	161.0	143.0	163.0
	SHC	60.0	87.0	18.0	78.0	113.0	27.0	96.0	136.0	37.0
	kW	23.3	22.8	25.8	23.6	23.1	26.0	23.7	23.3	26.2
125	TC	128.0	112.0	241.0	138.0	121.0	251.0	144.0	127.0	53.0
	SHC	46.0	74.0	104.0	63.0	99.0	117.0	80.0	121.0	50.0
	kW	25.3	24.9	17.5	25.6	25.1	17.7	25.7	25.3	10.4

RGF/RAF210**4/7/M/N — Unit with Hot Gas Re-Heat in Hot Gas Reheat Mode — Cooling Capacities

TEMP (°F) AIR ENTERING CONDENSER (Edb)		AIR ENTERING EVAPORATOR — Ewb (°F)								
		75 Dry Bulb 62.5 Wet Bulb (50% Relative)			75 Dry Bulb 64 Wet Bulb (56% Relative)			75 Dry Bulb 65.3 Wet Bulb (60% Relative)		
		Air Entering Evaporator — cfm								
		5250	7000	8750	5250	7000	8750	5250	7000	8750
80	TC	86.0	92.0	93.0	89.0	95.0	100.0	95.0	102.0	104.0
	SHC	11.0	24.0	36.0	0.0	12.0	25.0	-6.0	5.0	14.0
	kW	12.9	12.9	12.9	12.9	12.9	13.0	12.9	12.9	13.0
75	TC	89.0	95.0	99.0	91.0	98.0	101.0	98.0	104.0	99.0
	SHC	13.0	28.0	42.0	3.0	14.0	26.0	-2.0	7.0	23.0
	kW	12.9	12.9	12.9	12.9	12.9	13.0	12.9	12.9	13.0
70	TC	90.0	97.0	100.0	96.0	100.0	103.0	100.0	105.0	110.0
	SHC	15.0	30.0	43.0	7.0	17.0	28.0	-1.0	9.0	20.0
	kW	12.9	12.9	12.9	12.9	12.9	13.0	12.9	12.9	13.0
60	TC	95.0	101.0	105.0	99.0	108.0	112.0	105.0	102.0	114.0
	SHC	20.0	34.0	48.0	10.0	24.0	37.0	5.0	21.0	24.0
	kW	12.9	12.9	12.9	12.9	12.9	13.0	12.9	12.9	13.0
50	TC	99.0	105.0	109.0	106.0	112.0	116.0	110.0	118.0	119.0
	SHC	24.0	38.0	52.0	17.0	29.0	41.0	10.0	20.0	28.0
	kW	12.9	12.9	12.9	12.9	12.9	13.0	12.9	12.9	13.0
40	TC	100.0	109.0	113.0	109.0	113.0	120.0	115.0	122.0	123.0
	SHC	26.0	42.0	56.0	21.0	30.0	45.0	15.0	25.0	33.0
	kW	12.9	12.9	12.9	12.9	12.9	13.0	12.9	12.9	13.0

LEGEND

- Edb — Entering Dry Bulb
- Ewb — Entering Wet Bulb
- kW — Compressor Power Input
- SCFM/BF — Standard Cubic Feet per Minute/Bypass Factor
- SHC — Sensible Heat Capacity (1000 Btuh) Gross
- TC — Total Capacity (1000 Btuh) Gross

Performance data (cont)

RGF/RAF240 Two Stage Cooling Capacities

RGF/RAF240			AMBIENT TEMPERATURE (°F)																
			85			95			105			115			125				
			EA (db)			EA (db)			EA (db)			EA (db)			EA (db)				
			75	80	85	75	80	85	75	80	85	75	80	85	75	80	85		
6000 cfm	EA (wb)	58	TC	221.9	221.9	240.0	213.2	213.2	233.3	204.5	204.5	224.0	192.4	192.4	218.5	181.5	181.5	206.4	
			SHC	186.3	213.2	240.0	180.3	206.8	233.3	172.6	198.3	224.0	166.3	192.4	218.5	156.5	181.5	206.4	
		62	TC	241.3	241.3	241.3	227.5	227.5	227.5	215.2	215.2	215.2	202.5	202.5	203.4	188.5	188.5	195.8	
			SHC	169.9	198.1	226.2	161.2	189.5	217.9	154.1	182.4	210.7	146.9	175.2	203.4	139.4	167.6	195.8	
		67	TC	263.0	263.0	263.0	250.9	250.9	250.9	237.8	237.8	237.8	223.7	223.7	223.7	—	—	—	
			SHC	139.5	168.0	196.5	133.3	162.1	191.0	126.7	155.7	184.8	119.7	149.0	178.3	—	—	—	
	72	TC	289.6	289.6	289.6	276.3	276.3	276.3	262.1	262.1	262.1	246.8	246.8	246.8	—	—	—		
		SHC	110.9	138.9	166.9	104.2	132.6	161.0	97.3	126.2	155.0	90.1	119.3	148.5	—	—	—		
	76	TC	—	312.9	312.9	—	298.7	298.7	—	283.3	283.3	—	266.9	266.9	—	—	—		
		SHC	—	113.6	146.6	—	107.5	140.5	—	101.3	134.3	—	94.5	119.3	—	—	—		
	7000 cfm	EA (wb)	58	TC	236.7	236.7	258.3	225.1	225.1	254.7	215.0	215.0	243.6	204.0	204.0	231.5	192.1	192.1	218.4
				SHC	200.3	229.3	258.3	195.4	225.1	254.7	186.3	215.0	243.6	176.5	204.0	231.5	165.9	192.1	218.4
62			TC	247.5	247.5	247.5	234.7	234.7	237.5	222.9	222.9	231.0	209.4	209.4	223.1	195.2	195.2	216.1	
			SHC	180.1	212.4	244.7	172.6	205.0	237.5	166.5	198.7	231.0	158.9	191.0	223.1	151.7	183.9	216.1	
67			TC	272.3	272.3	272.3	259.4	259.4	259.4	245.5	245.5	245.5	230.6	230.6	230.6	—	—	—	
			SHC	148.9	182.3	215.6	142.5	176.1	209.8	135.7	169.4	203.2	128.5	162.5	196.4	—	—	—	
72		TC	299.2	299.2	299.2	285.2	285.2	285.2	270.1	270.1	270.1	254.0	254.0	254.0	—	—	—		
		SHC	115.1	148.1	181.0	108.4	141.7	175.0	101.4	135.1	168.7	94.1	128.1	162.0	—	—	—		
76		TC	—	318.7	318.7	—	307.6	307.6	—	291.6	291.6	—	274.3	274.3	—	—	—		
		SHC	—	118.9	154.9	—	113.2	139.9	—	106.6	137.4	—	99.7	132.2	—	—	—		
8000 cfm		EA (wb)	58	TC	246.2	246.2	278.2	234.4	234.4	265.4	225.4	225.4	255.2	213.7	213.7	242.3	201.0	201.0	228.3
				SHC	214.1	246.2	278.2	203.4	234.4	265.4	195.5	225.4	255.2	185.0	213.7	242.3	173.7	201.0	228.3
	62		TC	254.7	254.7	264.7	242.3	242.3	257.4	229.4	229.4	251.2	215.4	215.4	243.0	202.8	202.8	232.8	
			SHC	192.2	228.4	264.7	185.2	221.3	257.4	178.6	214.9	251.2	170.9	207.0	243.0	162.1	197.4	232.8	
	67		TC	278.7	278.7	278.7	266.1	266.1	266.1	251.5	251.5	251.5	236.0	236.0	236.0	—	—	—	
			SHC	157.2	195.1	233.1	151.2	189.4	227.6	144.3	182.7	221.1	137.1	175.6	214.2	—	—	—	
	72	TC	305.5	305.5	305.5	292.1	292.1	292.1	274.7	274.7	274.7	259.6	259.6	259.6	—	—	—		
		SHC	118.8	156.5	194.2	112.4	150.5	188.6	113.6	151.2	188.9	98.0	136.7	175.5	—	—	—		
	76	TC	—	327.5	327.5	—	314.9	314.9	—	297.9	297.9	—	279.9	279.9	—	—	—		
		SHC	—	124.1	163.4	—	118.5	154.3	—	111.6	148.5	—	104.5	142.2	—	—	—		
	9000 cfm	EA (wb)	58	TC	256.1	256.1	289.3	245.5	245.5	277.7	234.1	234.1	265.1	221.7	221.7	251.3	—	—	—
				SHC	222.9	256.1	289.3	213.4	245.5	277.7	203.2	234.1	265.1	192.1	221.7	251.3	—	—	—
62			TC	260.8	260.8	284.3	248.4	248.4	276.7	235.5	235.5	268.5	223.0	223.0	257.6	—	—	—	
			SHC	204.0	244.1	284.3	196.8	236.8	276.7	189.2	228.9	268.5	180.7	219.1	257.6	—	—	—	
67			TC	285.5	285.5	285.5	271.4	271.4	271.4	256.4	256.4	256.4	240.2	240.2	240.2	—	—	—	
			SHC	166.1	208.7	251.3	159.5	202.2	245.0	152.5	195.5	238.4	145.2	188.1	231.1	—	—	—	
72		TC	312.7	312.7	312.7	297.6	297.6	297.6	281.3	281.3	281.3	263.9	263.9	263.9	—	—	—		
		SHC	122.8	165.4	208.0	116.1	159.0	201.9	109.0	152.2	195.5	101.5	145.1	188.6	—	—	—		
76		TC	—	336.2	336.2	—	320.7	320.7	—	302.9	302.9	—	284.3	284.3	—	—	—		
		SHC	—	129.4	171.6	—	123.2	164.6	—	116.2	158.3	—	109.0	151.7	—	—	—		
10000 cfm		EA (wb)	58	TC	264.7	264.7	299.0	253.6	253.6	286.7	241.7	241.7	273.5	228.7	228.7	259.2	—	—	—
				SHC	230.4	264.7	299.0	220.5	253.6	286.7	209.8	241.7	273.5	198.3	228.7	259.2	—	—	—
	62		TC	266.6	266.6	300.7	256.2	256.2	287.8	246.0	246.0	267.2	231.6	231.6	258.5	—	—	—	
			SHC	214.1	257.4	300.7	204.6	246.2	287.8	191.0	229.1	267.2	182.8	220.7	258.5	—	—	—	
	67		TC	290.3	290.3	290.3	275.7	275.7	275.7	260.2	260.2	260.2	243.7	243.7	246.7	—	—	—	
			SHC	174.2	221.3	268.4	167.5	214.7	261.8	160.1	207.3	254.4	152.5	199.6	246.7	—	—	—	
	72	TC	323.2	323.2	323.2	302.0	302.0	302.0	285.2	285.2	285.2	267.3	267.3	267.3	—	—	—		
		SHC	127.0	176.0	225.0	119.6	167.2	214.9	112.4	160.3	208.2	104.9	153.1	201.2	—	—	—		
	76	TC	—	344.9	344.9	—	324.7	324.7	—	306.8	306.8	—	287.8	287.8	—	—	—		
		SHC	—	134.8	179.3	—	127.5	173.9	—	120.6	167.6	—	113.3	160.8	—	—	—		

LEGEND

—	Do Not Operate
cfm	Cubic Feet Per Minute (Supply Air)
EA (db)	Entering Air Temperature (dry bulb)
EA (wb)	Entering Air Temperature (wet bulb)
SHC	Sensible Heat Capacity (1000 Btuh) Gross
TC	Total Capacity (1000 Btuh) Gross

NOTE: See minimum-maximum airflow ratings on page 7.

Performance data (cont)

RGF/RAF240 Single Stage Cooling Capacities

RGF/RAF240			AMBIENT TEMPERATURE (°F)																
			85			95			105			115			125				
			EA (db)			EA (db)			EA (db)			EA (db)			EA (db)				
			75	80	85	75	80	85	75	80	85	75	80	85	75	80	85		
3600 cfm	EA (wb)	58	TC	125.4	125.4	142.7	118.4	118.4	135.1	111.2	111.2	127.3	103.5	103.5	119.0	95.6	95.6	110.4	
			SHC	108.1	125.4	142.7	101.7	118.4	135.1	95.0	111.2	127.3	88.0	103.5	119.0	80.8	95.6	110.4	
		62	TC	132.7	132.7	134.7	124.3	124.3	129.4	115.6	115.6	123.9	106.8	106.8	118.3	97.3	97.3	112.2	
			SHC	96.5	115.6	134.7	91.2	110.3	129.4	85.8	104.8	123.9	80.3	99.3	118.3	74.5	93.4	112.2	
		67	TC	147.6	147.6	147.6	138.7	138.7	138.7	129.4	129.4	129.4	119.5	119.5	119.5	109.5	109.5	109.5	
			SHC	77.8	97.0	116.2	72.5	91.7	110.9	67.1	86.2	105.4	61.4	80.6	99.8	55.8	75.0	94.1	
	72	TC	163.9	163.9	163.9	154.4	154.4	154.4	144.5	144.5	144.5	134.4	134.4	134.4	123.4	123.4	123.4		
		SHC	58.9	78.3	97.6	53.6	72.9	92.2	48.1	67.4	86.7	42.6	61.9	81.2	36.8	56.1	75.3		
	76	TC	—	177.8	177.8	—	168.0	168.0	—	157.9	157.9	—	147.0	147.0	—	135.3	135.3		
		SHC	—	63.1	82.9	—	57.8	77.6	—	52.4	72.2	—	46.8	66.4	—	40.9	60.5		
	4200 cfm	EA (wb)	58	TC	133.5	133.5	151.8	126.2	126.2	143.8	118.5	118.5	135.4	110.3	110.3	126.6	102.0	102.0	117.5
				SHC	115.3	133.5	151.8	108.6	126.2	143.8	101.5	118.5	135.4	94.1	110.3	126.6	86.5	102.0	117.5
62			TC	137.6	137.6	149.6	129.0	129.0	143.9	120.1	120.1	138.0	110.9	110.9	131.4	102.1	102.1	122.8	
			SHC	105.6	127.6	149.6	100.1	122.0	143.9	94.5	116.2	138.0	88.4	109.9	131.4	81.4	102.1	122.8	
67			TC	152.4	152.4	152.4	143.1	143.1	143.1	133.4	133.4	133.4	123.1	123.1	123.1	112.7	112.7	112.7	
			SHC	83.9	106.2	128.4	78.6	100.8	123.0	73.0	95.2	117.4	67.3	89.5	111.7	61.6	83.8	105.9	
72		TC	169.0	169.0	169.0	159.0	159.0	159.0	148.7	148.7	148.7	137.8	137.8	137.8	126.8	126.8	126.8		
		SHC	61.9	84.3	106.6	56.4	78.8	101.1	50.9	73.2	95.6	45.2	67.5	89.9	39.5	61.7	84.0		
76		TC	—	183.0	183.0	—	172.8	172.8	—	161.7	161.7	—	150.4	150.4	—	138.8	138.8		
		SHC	—	66.6	89.4	—	61.2	84.0	—	55.5	78.2	—	49.8	72.4	—	44.0	66.6		
4800 cfm		EA (wb)	58	TC	140.4	140.4	159.4	132.6	132.6	151.0	124.5	124.5	142.2	116.0	116.0	132.9	107.2	107.2	123.3
				SHC	121.4	140.4	159.4	114.3	132.6	151.0	106.9	124.5	142.2	99.1	116.0	132.9	91.1	107.2	123.3
	62		TC	141.9	141.9	163.0	134.4	134.4	152.4	124.7	124.7	148.2	116.1	116.1	138.7	107.4	107.4	128.9	
			SHC	113.8	138.4	163.0	106.0	129.2	152.4	101.1	124.7	148.2	93.6	116.1	138.7	85.9	107.4	128.9	
	67		TC	156.1	156.1	156.1	146.5	146.5	146.5	136.5	136.5	136.5	126.0	126.0	126.0	114.7	114.7	117.1	
			SHC	89.7	114.9	140.1	84.3	109.4	134.6	78.7	103.8	129.0	72.9	98.0	123.2	66.9	92.0	117.1	
	72	TC	172.8	172.8	172.8	162.8	162.8	162.8	151.9	151.9	151.9	140.7	140.7	140.7	129.4	129.4	129.4		
		SHC	64.6	89.9	115.3	59.1	84.5	109.8	53.5	78.8	104.1	47.7	73.0	98.2	41.9	67.2	92.4		
	76	TC	—	186.9	186.9	—	176.3	176.3	—	165.2	165.2	—	154.7	154.7	—	141.5	141.5		
		SHC	—	69.7	95.4	—	64.2	89.9	—	58.6	84.3	—	53.2	78.8	—	47.0	72.5		
	5400 cfm	EA (wb)	58	TC	146.2	146.2	165.8	138.1	138.1	157.1	129.7	129.7	147.9	120.8	120.8	138.2	111.6	111.6	128.2
				SHC	126.5	146.2	165.8	119.1	138.1	157.1	111.5	129.7	147.9	103.3	120.8	138.2	95.1	111.6	128.2
62			TC	146.3	146.3	172.6	140.0	140.0	157.2	129.8	129.8	154.2	120.9	120.9	144.2	111.8	111.8	133.9	
			SHC	120.1	146.3	172.6	109.8	133.5	157.2	105.5	129.8	154.2	97.6	120.9	144.2	89.6	111.8	133.9	
67			TC	159.1	159.1	159.1	149.3	149.3	149.3	139.0	139.0	140.1	128.2	128.2	134.1	117.3	117.3	128.1	
			SHC	95.2	123.3	151.4	89.7	117.8	145.8	84.0	112.1	140.1	78.2	106.2	134.1	72.4	100.2	128.1	
72		TC	175.9	175.9	175.9	165.6	165.6	165.6	154.4	154.4	154.4	144.1	144.1	144.1	131.4	131.4	131.4		
		SHC	67.1	95.3	123.6	61.6	89.8	118.1	55.9	84.1	112.3	50.4	78.6	106.8	44.3	72.4	100.6		
76		TC	—	190.0	190.0	—	179.2	179.2	—	167.9	167.9	—	156.5	156.5	—	143.7	143.7		
		SHC	—	72.7	101.3	—	67.2	95.8	—	61.5	90.1	—	55.9	84.3	—	49.8	78.2		
6000 cfm		EA (wb)	58	TC	151.1	151.1	171.4	142.8	142.8	162.3	134.1	134.1	152.8	124.9	124.9	142.7	115.0	115.0	132.0
				SHC	130.9	151.1	171.4	123.3	142.8	162.3	115.4	134.1	152.8	107.0	124.9	142.7	98.0	115.0	132.0
	62		TC	152.0	152.0	179.1	143.0	143.0	169.0	134.2	134.2	159.3	125.0	125.0	148.9	115.1	115.1	137.8	
			SHC	124.9	152.0	179.1	116.9	143.0	169.0	109.2	134.2	159.3	101.1	125.0	148.9	92.5	115.1	137.8	
	67		TC	161.5	161.5	162.3	151.5	151.5	156.5	141.1	141.1	150.7	130.1	130.1	144.6	118.6	118.6	138.0	
			SHC	100.4	131.3	162.3	94.8	125.7	156.5	89.1	119.9	150.7	83.3	113.9	144.6	77.1	107.5	138.0	
	72	TC	178.4	178.4	178.4	167.8	167.8	167.8	156.4	156.4	156.4	145.4	145.4	145.4	133.1	133.1	133.1		
		SHC	69.4	100.5	131.7	63.9	95.0	126.1	58.1	89.2	120.3	52.5	83.6	114.7	46.4	77.5	108.5		
	76	TC	—	192.6	192.6	—	181.6	181.6	—	171.4	171.4	—	158.5	158.5	—	145.4	145.4		
		SHC	—	75.5	107.0	—	70.0	101.4	—	64.7	96.0	—	58.6	89.9	—	52.4	83.6		

LEGEND

—	Do Not Operate
cfm	Cubic Feet Per Minute (Supply Air)
EA (db)	Entering Air Temperature (dry bulb)
EA (wb)	Entering Air Temperature (wet bulb)
SHC	Sensible Heat Capacity (1000 Btuh) Gross
TC	Total Capacity (1000 Btuh) Gross

NOTE: See minimum-maximum airflow ratings on page 7.

Performance data (cont)

RGF/RAF240**4/7/M/N — Unit with Hot Gas Re-Heat System in Subcooling Mode — Cooling Capacities

TEMP (°F) AIR ENTERING CONDENSER (Edb)		AIR ENTERING EVAPORATOR — SCFM/BF (80°F db)								
		6000/0.14			8000 /0.15			10000/0.17		
		Air Entering Evaporator — Ewb (°F)								
		72	67	62	72	67	62	72	67	62
75	TC	271.0	242.0	215.0	288.0	259.0	234.0	300.0	270.0	244.0
	SHC	103.0	131.0	159.0	119.0	157.0	195.0	134.0	180.0	226.0
	kW	20.5	19.9	19.4	20.9	20.3	19.8	21.1	20.5	20.0
85	TC	251.0	223.0	198.0	267.0	240.0	214.0	278.0	250.0	225.0
	SHC	85.0	114.0	143.0	100.0	139.0	177.0	114.0	161.0	207.0
	kW	22.1	21.5	21.0	22.5	21.9	21.3	22.7	22.1	21.6
95	TC	230.0	204.0	180.0	245.0	219.0	195.0	254.0	228.0	204.0
	SHC	66.0	97.0	127.0	80.0	120.0	159.0	93.0	142.0	188.0
	kW	23.9	23.3	22.7	24.3	23.7	23.1	24.5	23.9	23.4
105	TC	209.0	184.0	162.0	222.0	197.0	175.0	230.0	206.0	183.0
	SHC	48.0	79.0	110.0	60.0	101.0	141.0	72.0	122.0	169.0
	kW	25.9	25.3	24.7	26.2	25.6	25.1	26.5	25.9	25.3
115	TC	187.0	164.0	142.0	199.0	175.0	154.0	206.0	182.0	161.0
	SHC	29.0	61.0	92.0	40.0	81.0	122.0	51.0	101.0	149.0
	kW	28.0	27.4	26.8	28.4	27.8	27.2	28.6	28.0	27.5
125	TC	165.0	142.0	122.0	175.0	153.0	132.0	181.0	159.0	138.0
	SHC	9.0	42.0	74.0	19.0	62.0	102.0	29.0	80.0	128.0
	kW	30.3	29.7	29.1	30.7	30.1	29.5	30.9	30.3	29.7

RGF/RAF240**4/7/M/N — Unit with Hot Gas Re-Heat System in Hot Gas Reheat Mode — Cooling Capacities

TEMP (°F) AIR ENTERING CONDENSER (Edb)		AIR ENTERING EVAPORATOR — Ewb (°F)								
		75 Dry Bulb 62.5 Wet Bulb (50% Relative)			75 Dry Bulb 64 Wet Bulb (56% Relative)			75 Dry Bulb 65.3 Wet Bulb (60% Relative)		
		Air Entering Evaporator — cfm								
		6000	8000	10000	6000	8000	10000	6000	8000	10000
80	TC	89.0	96.0	100.0	95.0	101.0	105.0	100.0	106.0	110.0
	SHC	5.0	19.0	33.0	-2.0	11.0	25.0	-5.0	7.0	19.0
	kW	16.0	16.1	16.1	16.0	16.1	16.2	16.1	16.1	16.2
75	TC	94.0	100.0	104.0	99.0	106.0	110.0	104.0	111.0	106.0
	SHC	9.0	23.0	37.0	1.0	14.0	27.0	-3.0	9.0	27.0
	kW	16.0	16.1	16.1	16.0	16.1	16.1	16.1	16.1	16.2
70	TC	98.0	105.0	109.0	103.0	110.0	114.0	108.0	115.0	119.0
	SHC	13.0	27.0	41.0	5.0	18.0	30.0	0.0	12.0	23.0
	kW	16.0	16.1	16.1	16.0	16.1	16.1	16.1	16.1	16.2
60	TC	107.0	114.0	118.0	112.0	119.0	123.0	117.0	116.0	128.0
	SHC	21.0	35.0	49.0	13.0	25.0	37.0	7.0	24.0	28.0
	kW	16.0	16.1	16.1	16.0	16.1	16.1	16.0	16.1	16.2
50	TC	115.0	123.0	128.0	120.0	128.0	132.0	125.0	132.0	137.0
	SHC	29.0	43.0	57.0	21.0	33.0	45.0	14.0	25.0	35.0
	kW	16.0	16.0	16.1	16.0	16.1	16.1	16.0	16.1	16.2
40	TC	123.0	131.0	136.0	128.0	136.0	141.0	133.0	141.0	146.0
	SHC	36.0	51.0	65.0	28.0	41.0	53.0	21.0	32.0	42.0
	kW	16.0	16.0	16.1	16.0	16.1	16.1	16.0	16.1	16.2

LEGEND

Edb	—	Entering Dry Bulb
Ewb	—	Entering Wet Bulb
kW	—	Compressor Power Input
SCFM/BF	—	Standard Cubic Feet per Minute/Bypass Factor
SHC	—	Sensible Heat Capacity (1000 Btuh) Gross
TC	—	Total Capacity (1000 Btuh) Gross

Performance data (cont)

RGF/RAF300 Two Stage Cooling Capacities

RGF/RAF300			AMBIENT TEMPERATURE (°F)																
			85			95			105			115			125				
			EA (db)			EA (db)			EA (db)			EA (db)			EA (db)				
			75	80	85	75	80	85	75	80	85	75	80	85	75	80	85		
7500 cfm	EA (wb)	58	TC	263.2	263.2	298.3	249.1	249.1	282.8	233.2	233.2	265.2	215.7	215.7	245.9	—	—	—	
			SHC	228.2	263.2	298.3	215.5	249.1	282.8	201.1	233.2	265.2	185.5	215.7	245.9	—	—	—	
		62	TC	277.0	277.0	281.7	259.9	259.9	271.7	240.8	240.8	260.6	219.9	219.9	248.0	—	—	—	
			SHC	204.3	243.0	281.7	194.4	233.0	271.7	183.7	222.1	260.6	171.9	209.9	248.0	—	—	—	
		67	TC	304.3	304.3	304.3	286.1	286.1	286.1	266.1	266.1	266.1	243.8	243.8	243.8	—	—	—	
			SHC	165.6	204.6	243.6	155.9	195.0	234.0	145.7	184.7	223.6	134.7	173.7	212.6	—	—	—	
	72	TC	334.1	334.1	334.1	315.1	315.1	315.1	293.9	293.9	293.9	270.8	270.8	270.8	—	—	—		
		SHC	126.0	165.3	204.7	116.6	155.9	195.2	106.5	145.8	185.0	95.8	135.0	174.2	—	—	—		
	76	TC	—	359.3	359.3	—	339.3	339.3	—	317.1	317.1	—	293.4	293.4	—	—	—		
		SHC	—	133.6	174.6	—	124.2	165.0	—	114.2	154.7	—	103.7	143.9	—	—	—		
	8750 cfm	EA (wb)	58	TC	278.0	278.0	314.8	263.0	263.0	298.3	246.5	246.5	280.1	228.1	228.1	259.7	—	—	—
				SHC	241.2	278.0	314.8	227.7	263.0	298.3	212.9	246.5	280.1	196.5	228.1	259.7	—	—	—
62			TC	285.9	285.9	309.5	268.6	268.6	298.7	249.2	249.2	286.3	228.5	228.5	270.8	—	—	—	
			SHC	221.1	265.3	309.5	210.9	254.8	298.7	199.5	242.9	286.3	186.3	228.5	270.8	—	—	—	
67			TC	312.9	312.9	312.9	294.0	294.0	294.0	273.2	273.2	273.2	250.2	250.2	250.2	—	—	—	
			SHC	176.9	221.9	266.9	167.2	212.1	257.1	156.9	201.7	246.6	145.8	190.6	235.4	—	—	—	
72		TC	343.1	343.1	343.1	323.2	323.2	323.2	301.2	301.2	301.2	277.4	277.4	277.4	—	—	—		
		SHC	131.2	176.5	221.8	121.7	166.9	212.2	111.5	156.6	201.8	100.8	145.9	190.9	—	—	—		
76		TC	—	368.3	368.3	—	347.3	347.3	—	324.5	324.5	—	300.1	300.1	—	—	—		
		SHC	—	139.9	186.5	—	130.3	176.7	—	120.2	166.4	—	109.7	155.6	—	—	—		
10000 cfm		EA (wb)	58	TC	289.9	289.9	328.1	274.6	274.6	311.3	257.3	257.3	292.1	238.2	238.2	271.0	—	—	—
				SHC	251.7	289.9	328.1	238.0	274.6	311.3	222.4	257.3	292.1	205.4	238.2	271.0	—	—	—
	62		TC	293.6	293.6	334.0	277.2	277.2	317.4	259.9	259.9	295.2	238.4	238.4	282.2	—	—	—	
			SHC	236.0	285.0	334.0	222.9	270.1	317.4	206.7	251.0	295.2	194.6	238.4	282.2	—	—	—	
	67		TC	319.5	319.5	319.5	300.1	300.1	300.1	278.7	278.7	278.7	255.3	255.3	257.0	—	—	—	
			SHC	187.7	238.4	289.2	177.8	228.5	279.2	167.3	217.9	268.5	156.1	206.5	257.0	—	—	—	
	72	TC	349.9	349.9	349.9	329.4	329.4	329.4	306.8	306.8	306.8	282.5	282.5	282.5	—	—	—		
		SHC	136.0	187.1	238.1	126.4	177.4	228.4	116.1	167.0	217.9	105.4	156.2	207.0	—	—	—		
	76	TC	—	375.2	375.2	—	353.6	353.6	—	330.2	330.2	—	305.1	305.1	—	—	—		
		SHC	—	145.6	197.9	—	136.0	188.0	—	125.8	177.7	—	115.2	166.8	—	—	—		
	11250 cfm	EA (wb)	58	TC	300.3	300.3	339.7	284.3	284.3	322.1	266.3	266.3	302.1	246.5	246.5	280.3	—	—	—
				SHC	260.9	300.3	339.7	246.6	284.3	322.1	230.4	266.3	302.1	212.8	246.5	280.3	—	—	—
62			TC	301.0	301.0	353.6	284.5	284.5	334.9	266.5	266.5	314.4	246.9	246.9	292.0	—	—	—	
			SHC	248.4	301.0	353.6	234.1	284.5	334.9	218.6	266.5	314.4	201.8	246.9	292.0	—	—	—	
67			TC	324.6	324.6	324.6	304.7	304.7	304.7	283.0	283.0	289.3	259.2	259.2	277.3	—	—	—	
			SHC	197.8	254.1	310.5	187.8	244.1	300.3	177.2	233.3	289.3	165.8	221.5	277.3	—	—	—	
72		TC	355.2	355.2	355.2	334.1	334.1	334.1	311.1	311.1	311.1	286.4	286.4	286.4	—	—	—		
		SHC	140.4	197.1	253.8	130.8	187.4	244.0	120.5	177.0	233.5	109.7	166.1	222.5	—	—	—		
76		TC	—	380.7	380.7	—	358.7	358.7	—	334.7	334.7	—	309.2	309.2	—	—	—		
		SHC	—	151.1	208.9	—	141.4	199.0	—	131.2	188.5	—	120.5	177.6	—	—	—		
12500 cfm		EA (wb)	58	TC	309.1	309.1	349.4	292.5	292.5	331.2	273.9	273.9	310.7	253.8	253.8	288.4	—	—	—
				SHC	268.7	309.1	349.4	253.8	292.5	331.2	237.2	273.9	310.7	219.2	253.8	288.4	—	—	—
	62		TC	312.9	312.9	347.1	292.6	292.6	344.3	274.2	274.2	323.3	254.0	254.0	300.2	—	—	—	
			SHC	247.5	297.3	347.1	241.0	292.6	344.3	225.1	274.2	323.3	207.7	254.0	300.2	—	—	—	
	67		TC	329.0	329.0	330.8	308.8	308.8	320.4	286.6	286.6	309.0	262.7	262.7	296.3	—	—	—	
			SHC	207.4	269.1	330.8	197.4	258.9	320.4	186.5	247.7	309.0	174.9	235.6	296.3	—	—	—	
	72	TC	359.5	359.5	359.5	338.0	338.0	338.0	314.6	314.6	314.6	289.5	289.5	289.5	—	—	—		
		SHC	144.6	206.8	269.0	134.9	197.0	259.1	124.5	186.5	248.5	113.7	175.6	237.5	—	—	—		
	76	TC	—	385.1	385.1	—	362.7	362.7	—	338.3	338.3	—	312.4	312.4	—	—	—		
		SHC	—	156.3	219.5	—	146.6	209.6	—	136.2	199.1	—	125.5	188.1	—	—	—		

LEGEND

—	Do Not Operate
cfm	Cubic Feet Per Minute (Supply Air)
EA (db)	Entering Air Temperature (dry bulb)
EA (wb)	Entering Air Temperature (wet bulb)
SHC	Sensible Heat Capacity (1000 Btuh) Gross
TC	Total Capacity (1000 Btuh) Gross

NOTE: See minimum-maximum airflow ratings on page 7.

Performance data (cont)

RGF/RAF300 Single Stage Cooling Capacities

RGF/RAF300			AMBIENT TEMPERATURE (°F)																
			85			95			105			115			125				
			EA (db)			EA (db)			EA (db)			EA (db)			EA (db)				
			75	80	85	75	80	85	75	80	85	75	80	85	75	80	85		
4950 cfm	EA (wb)	58	TC	152.8	152.8	173.7	143.8	143.8	164.0	134.2	134.2	153.6	123.9	123.9	142.3	112.4	112.4	129.7	
			SHC	131.9	152.8	173.7	123.7	143.8	164.0	114.9	134.2	153.6	105.5	123.9	142.3	95.0	112.4	129.7	
		62	TC	153.6	153.6	173.0	145.5	145.5	166.6	134.8	134.8	159.0	123.9	123.9	148.4	112.4	112.4	135.5	
			SHC	120.9	146.9	173.0	115.0	140.8	166.6	108.0	133.5	159.0	99.3	123.9	148.4	89.2	112.4	135.5	
		67	TC	171.9	171.9	171.9	161.0	161.0	161.0	149.4	149.4	149.4	136.8	136.8	136.8	122.3	122.3	122.3	
			SHC	95.5	121.8	148.2	89.1	115.4	141.7	82.5	108.8	135.1	75.5	101.7	128.0	68.0	94.3	120.5	
	72	TC	191.2	191.2	191.2	178.4	178.4	178.4	165.9	165.9	165.9	151.9	151.9	151.9	138.3	138.3	138.3		
		SHC	69.3	95.7	122.2	62.4	88.9	115.3	55.7	82.1	108.5	48.5	74.9	101.3	41.4	67.8	94.1		
	76	TC	—	207.1	207.1	—	194.5	194.5	—	180.5	180.5	—	166.4	166.4	—	151.4	151.4		
		SHC	—	74.6	101.5	—	67.9	94.7	—	60.9	87.6	—	53.8	80.4	—	46.4	73.0		
	5800 cfm	EA (wb)	58	TC	161.1	161.1	182.9	151.6	151.6	172.6	142.3	142.3	162.6	131.2	131.2	150.4	119.0	119.0	137.1
				SHC	139.3	161.1	182.9	130.6	151.6	172.6	122.1	142.3	162.6	111.9	131.2	150.4	100.9	119.0	137.1
62			TC	161.4	161.4	190.5	151.6	151.6	179.7	142.5	142.5	169.5	131.1	131.1	156.7	119.2	119.2	143.4	
			SHC	132.2	161.4	190.5	123.6	151.6	179.7	115.4	142.5	169.5	105.4	131.1	156.7	95.1	119.2	143.4	
67			TC	177.1	177.1	177.1	165.6	165.6	165.6	152.4	152.4	152.4	140.1	140.1	144.1	125.5	125.5	136.5	
			SHC	103.8	134.4	165.0	97.2	127.7	158.2	90.2	120.8	151.3	83.4	113.8	144.1	75.9	106.2	136.5	
72		TC	195.4	195.4	195.4	182.6	182.6	182.6	169.5	169.5	169.5	156.4	156.4	156.4	141.3	141.3	141.3		
		SHC	72.8	103.5	134.2	66.0	96.7	127.4	59.2	89.8	120.5	52.3	82.9	113.5	44.9	75.4	106.0		
76		TC	—	212.0	212.0	—	198.9	198.9	—	185.0	185.0	—	170.1	170.1	—	154.5	154.5		
		SHC	—	78.9	110.0	—	72.2	103.1	—	65.2	96.1	—	57.9	88.7	—	50.5	81.1		
6600 cfm		EA (wb)	58	TC	167.8	167.8	190.4	158.9	158.9	180.8	148.5	148.5	169.5	137.1	137.1	157.0	124.4	124.4	143.1
				SHC	145.2	167.8	190.4	137.0	158.9	180.8	127.6	148.5	169.5	117.2	137.1	157.0	105.7	124.4	143.1
	62		TC	168.9	168.9	199.3	159.0	159.0	188.2	148.7	148.7	176.7	137.1	137.1	163.7	124.4	124.4	149.3	
			SHC	138.6	168.9	199.3	129.9	159.0	188.2	120.7	148.7	176.7	110.6	137.1	163.7	99.5	124.4	149.3	
	67		TC	180.6	180.6	180.6	168.8	168.8	173.0	156.4	156.4	165.9	142.7	142.7	158.4	128.1	128.1	150.4	
			SHC	111.0	145.3	179.6	104.4	138.7	173.0	97.6	131.7	165.9	90.3	124.4	158.4	82.7	116.5	150.4	
	72	TC	199.3	199.3	199.3	185.3	185.3	185.3	172.0	172.0	172.0	158.7	158.7	158.7	143.3	143.3	143.3		
		SHC	76.2	110.8	145.4	69.1	103.7	138.3	62.2	96.8	131.3	55.4	89.8	124.3	47.9	82.3	116.7		
	76	TC	—	215.9	215.9	—	201.2	201.2	—	188.2	188.2	—	172.6	172.6	—	156.6	156.6		
		SHC	—	82.9	117.7	—	75.7	110.5	—	69.0	103.6	—	61.6	96.1	—	54.0	88.4		
	7450 cfm	EA (wb)	58	TC	175.0	175.0	198.4	164.5	164.5	186.9	153.8	153.8	175.4	142.3	142.3	162.8	129.0	129.0	148.2
				SHC	151.6	175.0	198.4	142.0	164.5	186.9	132.3	153.8	175.4	121.8	142.3	162.8	109.8	129.0	148.2
62			TC	174.7	174.7	205.9	163.8	163.8	193.7	154.0	154.0	182.8	141.7	141.7	169.0	129.0	129.0	154.6	
			SHC	143.5	174.7	205.9	134.0	163.8	193.7	125.3	154.0	182.8	114.5	141.7	169.0	103.4	129.0	154.6	
67			TC	182.6	182.6	194.8	171.4	171.4	187.6	158.8	158.8	180.1	145.2	145.2	172.4	130.5	130.5	163.4	
			SHC	118.1	156.5	194.8	111.5	149.5	187.6	104.4	142.3	180.1	97.2	134.8	172.4	89.2	126.3	163.4	
72		TC	202.4	202.4	202.4	188.0	188.0	188.0	174.7	174.7	174.7	160.8	160.8	160.8	145.1	145.1	145.1		
		SHC	79.5	118.1	156.7	72.3	110.9	149.5	65.4	104.0	142.6	58.5	97.0	135.4	51.0	89.4	127.8		
76		TC	—	217.2	217.2	—	204.7	204.7	—	189.9	189.9	—	174.5	174.5	—	158.4	158.4		
		SHC	—	86.2	125.1	—	79.7	118.4	—	72.5	111.1	—	65.2	103.6	—	57.5	95.7		
8250 cfm		EA (wb)	58	TC	179.9	179.9	203.9	168.7	168.7	191.6	158.0	158.0	180.0	146.0	146.0	166.9	132.7	132.7	152.3
				SHC	156.0	179.9	203.9	145.8	168.7	191.6	136.0	158.0	180.0	125.1	146.0	166.9	113.1	132.7	152.3
	62		TC	180.2	180.2	212.2	168.4	168.4	198.9	158.1	158.1	187.4	146.3	146.3	174.2	132.7	132.7	158.8	
			SHC	148.2	180.2	212.2	137.8	168.4	198.9	128.7	158.1	187.4	118.4	146.3	174.2	106.5	132.7	158.8	
	67		TC	185.1	185.1	208.3	173.3	173.3	200.9	160.6	160.6	193.1	147.4	147.4	183.9	132.8	132.8	172.0	
			SHC	124.6	166.4	208.3	117.8	159.3	200.9	110.6	151.8	193.1	102.8	143.4	183.9	93.7	132.8	172.0	
	72	TC	202.3	202.3	202.3	191.4	191.4	191.4	176.6	176.6	176.6	162.3	162.3	162.3	146.4	146.4	146.4		
		SHC	81.6	124.1	166.6	75.5	117.8	160.0	68.3	110.6	152.9	61.3	103.4	145.6	53.8	95.9	137.9		
	76	TC	—	221.2	221.2	—	206.7	206.7	—	191.7	191.7	—	176.1	176.1	—	159.7	159.7		
		SHC	—	90.2	132.6	—	83.1	125.3	—	75.9	118.0	—	68.4	110.4	—	60.7	102.4		

LEGEND

—	Do Not Operate
cfm	Cubic Feet Per Minute (Supply Air)
EA (db)	Entering Air Temperature (dry bulb)
EA (wb)	Entering Air Temperature (wet bulb)
SHC	Sensible Heat Capacity (1000 Btuh) Gross
TC	Total Capacity (1000 Btuh) Gross

NOTE: See minimum-maximum airflow ratings on page 7.

Performance data (cont)

RGF/RAF300**4/7/M/N — Unit with Hot Gas Re-Heat System in Subcooling Mode — Cooling Capacities

TEMP (°F) AIR ENTERING CONDENSER (Edb)		AIR ENTERING EVAPORATOR — SCFM/BF (80°F db)								
		7500/0.14			10000 /0.15			12500/0.17		
		Air Entering Evaporator — Ewb (°F)								
		72	67	62	72	67	62	72	67	62
75	TC	316.0	292.0	263.0	343.0	312.0	282.0	353.0	321.0	292.0
	SHC	124.0	168.0	204.0	152.0	200.0	245.0	168.0	225.0	279.0
	kW	24.1	23.8	23.2	25.0	24.3	23.6	25.1	24.4	23.8
85	TC	302.0	272.0	244.0	320.0	289.0	262.0	332.0	301.0	273.0
	SHC	112.0	150.0	187.0	131.0	179.0	226.0	148.0	206.0	261.0
	kW	26.5	25.8	25.1	26.9	26.2	25.6	27.2	26.5	25.9
95	TC	280.0	252.0	225.0	297.0	268.0	242.0	307.0	278.0	252.0
	SHC	93.0	131.0	169.0	110.0	160.0	208.0	126.0	186.0	241.0
	kW	28.7	28.0	27.3	29.1	28.4	27.7	29.4	28.7	28.0
105	TC	259.0	230.0	206.0	274.0	245.0	220.0	284.0	255.0	230.0
	SHC	74.0	113.0	151.0	90.0	139.0	189.0	105.0	165.0	221.0
	kW	31.2	30.4	29.7	31.6	30.8	30.1	31.9	31.1	30.4
115	TC	237.0	209.0	185.0	251.0	222.0	199.0	260.0	231.0	208.0
	SHC	55.0	93.0	133.0	70.0	119.0	169.0	84.0	143.0	200.0
	kW	33.8	33.0	32.3	34.2	33.4	32.7	34.5	33.6	33.0
125	TC	212.0	187.0	164.0	225.0	199.0	177.0	232.0	206.0	185.0
	SHC	33.0	74.0	115.0	46.0	98.0	149.0	60.0	121.0	179.0
	kW	36.5	35.7	35.1	36.9	36.1	35.4	37.1	36.3	35.7

RGF/RAF300**4/7/M/N — Unit with Hot Gas Re-Heat System in Hot Gas Reheat Mode — Cooling Capacities

TEMP (°F) AIR ENTERING CONDENSER (Edb)		AIR ENTERING EVAPORATOR — Ewb (°F)								
		75 Dry Bulb 62.5 Wet Bulb (50% Relative)			75 Dry Bulb 64 Wet Bulb (56% Relative)			75 Dry Bulb 65.3 Wet Bulb (60% Relative)		
		Air Entering Evaporator — cfm								
		7500	10000	12500	7500	10000	12500	7500	10000	12500
80	TC	130.0	139.0	145.0	138.0	147.0	154.0	146.0	154.0	162.0
	SHC	39.0	60.0	81.0	31.0	49.0	67.0	24.0	39.0	55.0
	kW	17.8	17.9	17.9	17.9	17.9	18.0	17.9	18.0	18.0
75	TC	134.0	144.0	150.0	143.0	152.0	158.0	150.0	160.0	155.0
	SHC	44.0	65.0	85.0	35.0	53.0	71.0	27.0	44.0	66.0
	kW	17.8	17.9	17.9	17.9	17.9	18.0	17.9	18.0	18.0
70	TC	138.0	147.0	154.0	146.0	156.0	162.0	154.0	163.0	170.0
	SHC	47.0	68.0	89.0	39.0	57.0	75.0	32.0	47.0	63.0
	kW	17.8	17.9	17.9	17.9	17.9	18.0	17.9	18.0	18.0
60	TC	146.0	156.0	162.0	154.0	164.0	171.0	162.0	161.0	175.0
	SHC	55.0	76.0	96.0	46.0	65.0	82.0	39.0	63.0	68.0
	kW	17.8	17.9	17.9	17.9	17.9	18.0	17.9	18.0	18.0
50	TC	154.0	163.0	170.0	162.0	172.0	179.0	169.0	179.0	186.0
	SHC	63.0	83.0	104.0	53.0	72.0	90.0	46.0	62.0	78.0
	kW	17.8	17.9	17.9	17.9	17.9	18.0	17.9	18.0	18.0
40	TC	160.0	171.0	177.0	169.0	179.0	186.0	176.0	187.0	194.0
	SHC	69.0	91.0	111.0	61.0	79.0	97.0	53.0	69.0	85.0
	kW	17.8	17.9	17.9	17.9	17.9	18.0	17.9	18.0	18.0

LEGEND

Edb	—	Entering Dry Bulb
Ewb	—	Entering Wet Bulb
kW	—	Compressor Power Input
SCFM/BF	—	Standard Cubic Feet per Minute/Bypass Factor
SHC	—	Sensible Heat Capacity (1000 Btuh) Gross
TC	—	Total Capacity (1000 Btuh) Gross

Performance data (cont)

RGF/RAF336 Two Stage Cooling Capacities

RGF/RAF336			AMBIENT TEMPERATURE (°F)																
			85			95			105			115			125				
			EA (db)			EA (db)			EA (db)			EA (db)			EA (db)				
			75	80	85	75	80	85	75	80	85	75	80	85	75	80	85		
8250 cfm	EA (wb)	58	TC	282.5	282.5	314.9	268.5	268.5	292.1	247.1	247.1	283.0	228.1	228.1	262.4	207.7	207.7	240.0	
			SHC	239.7	277.3	314.9	222.2	257.2	292.1	211.1	247.1	283.0	193.8	228.1	262.4	175.3	207.7	240.0	
		62	TC	301.8	301.8	301.8	282.4	282.4	282.4	261.0	261.0	267.9	237.7	237.7	253.6	212.8	212.8	238.8	
			SHC	213.1	253.3	293.4	200.8	241.0	281.2	187.6	227.8	267.9	173.5	213.5	253.6	158.9	198.8	238.8	
		67	TC	335.0	335.0	335.0	314.5	314.5	314.5	292.1	292.1	292.1	267.6	267.6	267.6	241.3	241.3	241.3	
			SHC	174.0	214.3	254.6	161.8	202.3	242.8	149.0	189.7	230.4	135.4	176.3	217.2	121.3	162.5	203.6	
	72	TC	371.2	371.2	371.2	349.5	349.5	349.5	325.8	325.8	325.8	300.0	300.0	300.0	—	—	—		
		SHC	134.6	173.4	212.3	122.1	161.4	200.8	108.9	148.8	188.7	95.2	135.5	175.9	—	—	—		
	76	TC	—	402.8	402.8	—	379.9	379.9	—	354.9	354.9	—	327.9	327.9	—	—	—		
		SHC	—	138.7	184.1	—	126.8	172.2	—	114.9	160.3	—	102.0	142.9	—	—	—		
	9650 cfm	EA (wb)	58	TC	299.2	299.2	340.0	282.3	282.3	321.8	263.9	263.9	301.8	243.9	243.9	279.9	222.2	222.2	256.3
				SHC	258.3	299.2	340.0	242.8	282.3	321.8	226.0	263.9	301.8	207.8	243.9	279.9	188.2	222.2	256.3
62			TC	313.1	313.1	324.1	292.9	292.9	311.4	270.8	270.8	297.8	247.4	247.4	282.6	223.7	223.7	263.9	
			SHC	231.9	278.0	324.1	219.3	265.4	311.4	205.8	251.8	297.8	191.3	237.0	282.6	175.0	219.5	263.9	
67			TC	346.7	346.7	346.7	325.3	325.3	325.3	301.9	301.9	301.9	276.4	276.4	276.4	249.2	249.2	249.2	
			SHC	187.4	234.3	281.2	175.1	222.2	269.3	162.0	209.3	256.6	148.3	195.8	243.3	134.1	181.8	229.4	
72		TC	383.2	383.2	383.2	360.4	360.4	360.4	335.7	335.7	335.7	308.9	308.9	308.9	—	—	—		
		SHC	140.8	186.7	232.6	128.2	174.5	220.8	115.0	161.7	208.5	101.2	148.3	195.5	—	—	—		
76		TC	—	414.7	414.7	—	390.8	390.8	—	364.9	364.9	—	337.0	337.0	—	—	—		
		SHC	—	147.2	192.7	—	135.3	182.6	—	122.7	164.7	—	109.4	153.5	—	—	—		
11000 cfm		EA (wb)	58	TC	314.1	314.1	356.6	296.5	296.5	337.6	277.3	277.3	316.7	256.3	256.3	293.8	233.7	233.7	269.1
				SHC	271.5	314.1	356.6	255.4	296.5	337.6	237.9	277.3	316.7	218.8	256.3	293.8	198.4	233.7	269.1
	62		TC	322.0	322.0	351.7	301.3	301.3	338.0	279.8	279.8	323.4	258.5	258.5	301.2	238.5	238.5	268.0	
			SHC	248.7	300.2	351.7	235.5	286.7	338.0	221.7	272.6	323.4	204.0	252.6	301.2	180.6	224.3	268.0	
	67		TC	355.5	355.5	355.5	333.3	333.3	333.3	309.1	309.1	309.1	283.0	283.0	283.0	—	—	—	
			SHC	199.6	252.8	305.9	187.1	240.4	293.8	173.9	227.5	281.0	160.0	213.6	267.3	—	—	—	
	72	TC	392.0	392.0	392.0	368.5	368.5	368.5	343.1	343.1	343.1	315.6	315.6	315.6	—	—	—		
		SHC	146.4	198.8	251.2	133.7	186.5	239.3	120.4	173.6	226.8	106.5	160.1	213.6	—	—	—		
	76	TC	—	423.7	423.7	—	399.0	399.0	—	372.4	372.4	—	343.6	343.6	—	—	—		
		SHC	—	154.5	200.9	—	142.2	190.8	—	129.5	179.6	—	116.0	167.3	—	—	—		
	12400 cfm	EA (wb)	58	TC	327.3	327.3	371.3	309.0	309.0	351.5	289.0	289.0	329.7	267.2	267.2	305.9	243.9	243.9	280.4
				SHC	283.2	327.3	371.3	266.5	309.0	351.5	248.3	289.0	329.7	228.5	267.2	305.9	207.4	243.9	280.4
62			TC	330.8	330.8	376.4	311.6	311.6	358.7	291.6	291.6	336.7	271.7	271.7	305.2	244.1	244.1	292.9	
			SHC	264.0	320.2	376.4	249.0	303.9	358.7	231.6	284.2	336.7	209.1	257.2	305.2	195.4	244.1	292.9	
67			TC	362.6	362.6	362.6	339.8	339.8	339.8	315.2	315.2	315.2	288.4	288.4	290.8	—	—	—	
			SHC	211.5	271.0	330.5	198.8	258.4	318.0	185.6	245.3	305.0	171.4	231.1	290.8	—	—	—	
72		TC	399.3	399.3	399.3	375.2	375.2	375.2	349.2	349.2	349.2	320.9	320.9	320.9	—	—	—		
		SHC	151.7	210.7	269.7	139.0	198.4	257.7	125.7	185.3	245.0	111.7	171.7	231.7	—	—	—		
76		TC	—	431.2	431.2	—	405.8	405.8	—	378.5	378.5	—	349.0	349.0	—	—	—		
		SHC	—	161.3	216.4	—	148.9	205.2	—	136.0	193.3	—	122.4	180.6	—	—	—		
13750 cfm		EA (wb)	58	TC	338.2	338.2	383.5	319.3	319.3	362.9	298.7	298.7	340.5	276.2	276.2	315.9	—	—	—
				SHC	292.9	338.2	383.5	275.6	319.3	362.9	256.8	298.7	340.5	236.5	276.2	315.9	—	—	—
	62		TC	341.0	341.0	390.0	322.0	322.0	369.9	303.6	303.6	338.2	276.5	276.5	329.6	—	—	—	
			SHC	273.7	331.8	390.0	257.5	313.7	369.9	235.2	286.7	338.2	223.5	276.5	329.6	—	—	—	
	67		TC	368.3	368.3	368.3	345.1	345.1	345.1	319.9	319.9	326.7	292.5	292.5	311.9	—	—	—	
			SHC	222.4	287.7	353.0	209.6	275.0	340.5	196.0	261.4	326.7	181.5	246.7	311.9	—	—	—	
	72	TC	405.0	405.0	405.0	380.4	380.4	380.4	353.8	353.8	353.8	325.0	325.0	325.0	—	—	—		
		SHC	156.7	221.8	287.0	143.8	209.3	274.9	130.4	196.3	262.1	116.4	182.5	248.6	—	—	—		
	76	TC	—	437.0	437.0	—	411.0	411.0	—	383.2	383.2	—	353.1	353.1	—	—	—		
		SHC	—	167.5	229.7	—	155.0	218.1	—	142.0	205.8	—	128.2	192.8	—	—	—		

LEGEND

—	Do Not Operate
cfm	Cubic Feet Per Minute (Supply Air)
EA (db)	Entering Air Temperature (dry bulb)
EA (wb)	Entering Air Temperature (wet bulb)
SHC	Sensible Heat Capacity (1000 Btuh) Gross
TC	Total Capacity (1000 Btuh) Gross

NOTE: See minimum-maximum airflow ratings on page 7.

Performance data (cont)

RGF/RAF336 Single Stage Cooling Capacities

RGF/RAF336			AMBIENT TEMPERATURE (°F)																
			85			95			105			115			125				
			EA (db)			EA (db)			EA (db)			EA (db)			EA (db)				
			75	80	85	75	80	85	75	80	85	75	80	85	75	80	85		
4950 cfm	EA (wb)	58	TC	153.0	153.0	175.4	142.0	142.0	163.6	130.5	130.5	151.5	118.0	118.0	138.0	104.5	104.5	123.5	
			SHC	130.7	153.0	175.4	120.3	142.0	163.6	109.6	130.5	151.5	97.9	118.0	138.0	85.5	104.5	123.5	
		62	TC	162.9	162.9	165.4	149.7	149.7	156.2	135.9	135.9	145.0	121.5	121.5	137.1	106.0	106.0	126.5	
			SHC	115.9	140.7	165.4	106.7	131.4	156.2	95.9	120.5	145.0	87.7	112.4	137.1	77.5	102.0	126.5	
		67	TC	182.9	182.9	182.9	169.5	169.5	169.5	155.1	155.1	155.1	139.7	139.7	139.7	123.1	123.1	123.1	
			SHC	92.0	117.0	142.0	82.9	107.9	133.0	73.4	98.5	123.7	63.6	88.8	114.1	53.4	78.7	104.0	
	72	TC	205.2	205.2	205.2	190.8	190.8	190.8	175.6	175.6	175.6	159.7	159.7	159.7	142.3	142.3	142.3		
		SHC	67.9	92.4	116.9	58.4	83.1	107.7	48.7	73.5	98.3	38.7	63.7	88.6	28.2	53.4	78.5		
	76	TC	—	224.6	224.6	—	209.2	209.2	—	193.8	193.8	—	177.0	177.0	—	—	—		
		SHC	—	72.3	99.5	—	62.9	87.4	—	53.5	75.6	—	43.6	66.9	—	—	—		
	5800 cfm	EA (wb)	58	TC	164.4	164.4	188.0	152.7	152.7	175.5	140.5	140.5	162.5	127.5	127.5	148.5	113.3	113.3	133.3
				SHC	140.9	164.4	188.0	129.9	152.7	175.5	118.5	140.5	162.5	106.4	127.5	148.5	93.3	113.3	133.3
62			TC	169.0	169.0	185.1	155.9	155.9	175.8	142.4	142.4	165.8	128.9	128.9	152.0	113.5	113.5	140.2	
			SHC	128.1	156.6	185.1	118.9	147.4	175.8	109.2	137.5	165.8	97.6	124.8	152.0	86.8	113.5	140.2	
67			TC	188.1	188.1	188.1	174.3	174.3	174.3	160.5	160.5	160.5	144.6	144.6	144.6	127.4	127.4	127.4	
			SHC	100.0	129.1	158.2	91.0	120.3	149.5	82.0	111.3	140.7	72.1	101.5	130.9	61.7	91.2	120.6	
72		TC	211.8	211.8	211.8	196.9	196.9	196.9	181.6	181.6	181.6	164.8	164.8	164.8	146.8	146.8	146.8		
		SHC	72.1	100.9	129.6	62.6	91.5	120.4	52.9	82.0	111.1	42.7	72.0	101.2	32.1	61.5	91.0		
76		TC	—	230.4	230.4	—	215.6	215.6	—	—	—	—	—	—	—	—	—		
		SHC	—	77.1	106.3	—	68.0	95.0	—	—	—	—	—	—	—	—	—		
6600 cfm		EA (wb)	58	TC	173.2	173.2	197.7	161.2	161.2	185.0	148.6	148.6	171.5	134.9	134.9	156.8	120.2	120.2	140.9
				SHC	148.8	173.2	197.7	137.5	161.2	185.0	125.7	148.6	171.5	113.0	134.9	156.8	99.4	120.2	140.9
	62		TC	174.5	174.5	201.3	162.1	162.1	189.5	149.2	149.2	178.3	135.1	135.1	164.3	120.3	120.3	148.1	
			SHC	138.3	169.8	201.3	127.9	158.7	189.5	117.7	148.0	178.3	105.9	135.1	164.3	92.6	120.3	148.1	
	67		TC	193.8	193.8	193.8	179.1	179.1	179.1	164.5	164.5	164.5	146.8	146.8	146.8	129.2	129.2	132.6	
			SHC	108.4	141.5	174.5	99.1	132.1	165.2	89.5	122.6	155.7	78.4	111.4	144.4	66.9	99.8	132.6	
	72	TC	219.7	219.7	219.7	201.7	201.7	201.7	185.7	185.7	185.7	168.4	168.4	168.4	149.9	149.9	149.9		
		SHC	77.0	110.0	143.0	66.3	99.1	132.0	56.4	89.5	122.5	46.2	79.4	112.6	35.6	68.9	102.2		
	76	TC	—	236.6	236.6	—	—	—	—	—	—	—	—	—	—	—	—		
		SHC	—	82.0	113.0	—	—	—	—	—	—	—	—	—	—	—	—		
	7450 cfm	EA (wb)	58	TC	180.9	180.9	206.2	168.9	168.9	193.4	155.5	155.5	179.1	141.5	141.5	164.1	126.3	126.3	147.7
				SHC	155.6	180.9	206.2	144.3	168.9	193.4	131.9	155.5	179.1	119.0	141.5	164.1	104.9	126.3	147.7
62			TC	181.8	181.8	212.5	169.0	169.0	201.8	155.7	155.7	187.2	141.7	141.7	171.9	126.5	126.5	155.1	
			SHC	146.1	179.3	212.5	136.2	169.0	201.8	124.2	155.7	187.2	111.6	141.7	171.9	97.9	126.5	155.1	
67			TC	200.8	200.8	200.8	185.8	185.8	185.8	170.7	170.7	174.4	151.7	151.7	161.8	132.8	132.8	148.4	
			SHC	118.7	155.9	193.0	109.6	146.7	183.9	100.0	137.2	174.4	88.0	124.9	161.8	75.3	111.8	148.4	
72		TC	227.5	227.5	227.5	209.0	209.0	209.0	189.1	189.1	189.1	171.4	171.4	171.4	152.5	152.5	152.5		
		SHC	82.3	119.9	157.4	71.5	108.8	146.1	59.9	97.1	134.3	49.7	87.0	124.3	39.0	76.4	113.8		
76		TC	—	—	—	—	—	—	—	—	—	—	—	—	—	—	—		
		SHC	—	—	—	—	—	—	—	—	—	—	—	—	—	—	—		
8250 cfm		EA (wb)	58	TC	187.9	187.9	213.9	174.9	174.9	200.1	161.5	161.5	185.8	146.9	146.9	170.1	131.2	131.2	153.2
				SHC	161.8	187.9	213.9	149.7	174.9	200.1	137.2	161.5	185.8	123.8	146.9	170.1	109.3	131.2	153.2
	62		TC	188.1	188.1	222.9	175.4	175.4	209.1	161.7	161.7	194.1	147.1	147.1	178.1	131.4	131.4	160.7	
			SHC	153.3	188.1	222.9	141.7	175.4	209.1	129.3	161.7	194.1	116.2	147.1	178.1	102.1	131.4	160.7	
	67		TC	207.0	207.0	210.7	190.2	190.2	200.5	175.9	175.9	191.9	155.7	155.7	177.6	135.4	135.4	162.3	
			SHC	128.7	169.7	210.7	118.5	159.5	200.5	109.9	150.9	191.9	96.7	137.1	177.6	82.5	122.4	162.3	
	72	TC	—	—	—	215.1	215.1	215.1	194.9	194.9	194.9	173.7	173.7	173.7	154.5	154.5	154.5		
		SHC	—	—	—	76.6	117.9	159.2	64.9	106.2	147.4	52.8	93.8	134.9	42.0	83.2	124.4		
	76	TC	—	—	—	—	—	—	—	—	—	—	—	—	—	—	—		
		SHC	—	—	—	—	—	—	—	—	—	—	—	—	—	—	—		

LEGEND

—	Do Not Operate
cfm	Cubic Feet Per Minute (Supply Air)
EA (db)	Entering Air Temperature (dry bulb)
EA (wb)	Entering Air Temperature (wet bulb)
SHC	Sensible Heat Capacity (1000 Btuh) Gross
TC	Total Capacity (1000 Btuh) Gross

NOTE: See minimum-maximum airflow ratings on page 7.

Performance data (cont)

RGF/RAF336**4/7/M/N — Unit with Hot Gas Re-Heat System in Subcooling Mode — Cooling Capacities

TEMP (°F) AIR ENTERING CONDENSER (Edb)		AIR ENTERING EVAPORATOR — SCFM/BF (80°F db)								
		8250/0.10			11000 /0.14			13750/0.18		
		Air Entering Evaporator — Ewb (°F)								
		72	67	62	72	67	62	72	67	62
75	TC	317.0	286.0	253.0	347.0	309.0	274.0	362.0	323.0	283.0
	SHC	108.0	150.0	187.0	137.0	185.0	232.0	157.0	214.0	266.0
	kW	28.4	27.9	27.3	29.2	28.4	27.8	29.5	28.7	27.9
85	TC	306.0	270.0	237.0	325.0	290.0	256.0	328.0	303.0	270.0
	SHC	98.0	135.0	172.0	117.0	168.0	215.0	126.0	196.0	253.0
	kW	30.7	30.0	29.3	31.2	30.4	29.8	31.1	30.7	30.1
95	TC	287.0	252.0	220.0	305.0	270.0	238.0	317.0	282.0	252.0
	SHC	81.0	119.0	157.0	99.0	149.0	198.0	116.0	177.0	236.0
	kW	32.9	32.2	31.5	33.4	32.6	32.0	33.7	32.9	32.3
105	TC	267.0	234.0	204.0	283.0	250.0	220.0	294.0	260.0	231.0
	SHC	63.0	103.0	142.0	80.0	132.0	181.0	96.0	158.0	217.0
	kW	35.4	34.7	34.0	35.8	35.1	34.5	36.1	35.4	34.7
115	TC	245.0	215.0	187.0	260.0	229.0	201.0	269.0	238.0	211.0
	SHC	44.0	86.0	126.0	60.0	113.0	164.0	75.0	138.0	199.0
	kW	38.1	37.4	36.7	38.5	37.8	37.2	38.8	38.1	37.5
125	TC	223.0	194.0	167.0	236.0	207.0	180.0	244.0	214.0	189.0
	SHC	25.0	68.0	109.0	39.0	93.0	146.0	53.0	118.0	179.0
	kW	41.0	40.3	39.6	41.4	40.7	40.0	41.7	41.0	40.3

RGF/RAF336**4/7/M/N — Unit with Hot Gas Re-Heat System in Hot Gas Reheat Mode — Cooling Capacities

TEMP (°F) AIR ENTERING CONDENSER (Edb)		AIR ENTERING EVAPORATOR — Ewb (°F)								
		75 Dry Bulb 62.5 Wet Bulb (50% Relative)			75 Dry Bulb 64 Wet Bulb (56% Relative)			75 Dry Bulb 65.3 Wet Bulb (60% Relative)		
		Air Entering Evaporator — cfm								
		8250	11000	13750	8250	11000	13750	8250	11000	13750
80	TC	127.0	137.0	139.0	134.0	141.0	148.0	142.0	149.0	153.0
	SHC	13.0	37.0	55.0	-1.0	16.0	37.0	-10.0	4.0	19.0
	kW	20.7	20.8	21.2	21.0	21.2	21.3	21.1	21.4	23.6
75	TC	135.0	144.0	148.0	142.0	149.0	154.0	148.0	155.0	152.0
	SHC	21.0	44.0	66.0	7.0	24.0	43.0	-5.0	11.0	49.0
	kW	20.7	20.8	20.9	20.9	21.2	21.3	21.2	21.3	21.0
70	TC	142.0	151.0	157.0	151.0	159.0	165.0	157.0	166.0	173.0
	SHC	28.0	51.0	74.0	16.0	36.0	56.0	6.0	24.0	43.0
	kW	20.6	20.8	20.9	20.7	20.8	20.9	20.8	20.9	21.0
60	TC	156.0	165.0	172.0	165.0	174.0	180.0	172.0	167.0	188.0
	SHC	42.0	65.0	88.0	30.0	50.0	70.0	20.0	48.0	55.0
	kW	20.6	20.8	20.9	20.7	20.8	20.9	20.8	20.9	21.0
50	TC	170.0	177.0	186.0	178.0	185.0	194.0	185.0	193.0	202.0
	SHC	55.0	75.0	102.0	43.0	59.0	83.0	33.0	45.0	68.0
	kW	20.6	21.2	20.8	20.7	21.2	20.9	20.8	21.3	21.0
40	TC	183.0	193.0	199.0	191.0	201.0	208.0	198.0	209.0	216.0
	SHC	68.0	92.0	115.0	56.0	76.0	96.0	46.0	63.0	80.0
	kW	20.6	20.8	20.8	20.7	20.8	20.9	20.8	20.9	21.0

LEGEND

Edb	—	Entering Dry Bulb
Ewb	—	Entering Wet Bulb
kW	—	Compressor Power Input
SCFM/BF	—	Standard Cubic Feet per Minute/Bypass Factor
SHC	—	Sensible Heat Capacity (1000 Btuh) Gross
TC	—	Total Capacity (1000 Btuh) Gross

Performance data (cont)

Pressure Drop — Heating

17.5 to 27.5 Ton Electric Heat Units

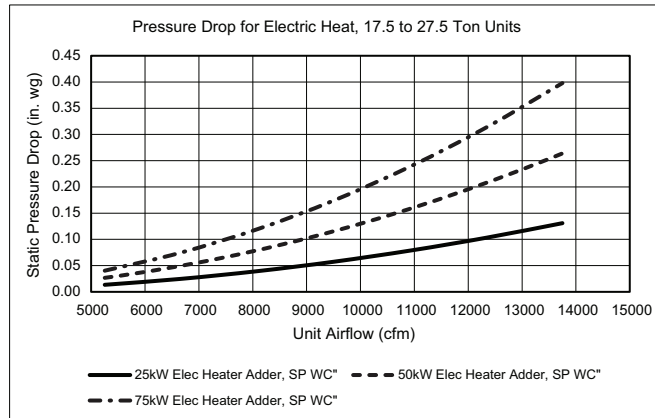

17.5 to 27.5 Ton Gas Heat Units

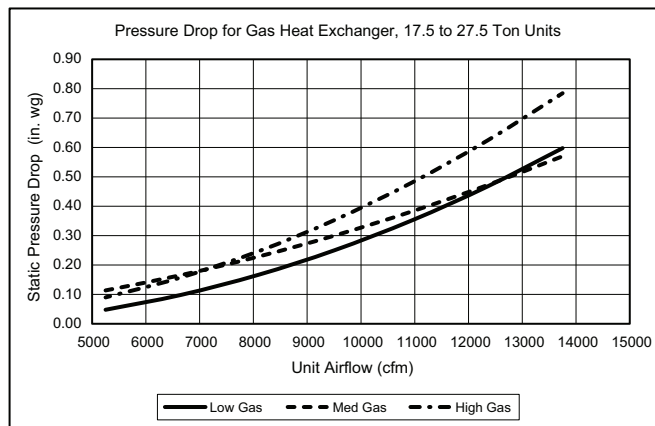

Static Pressure 17.5 to 27.5 Ton Units

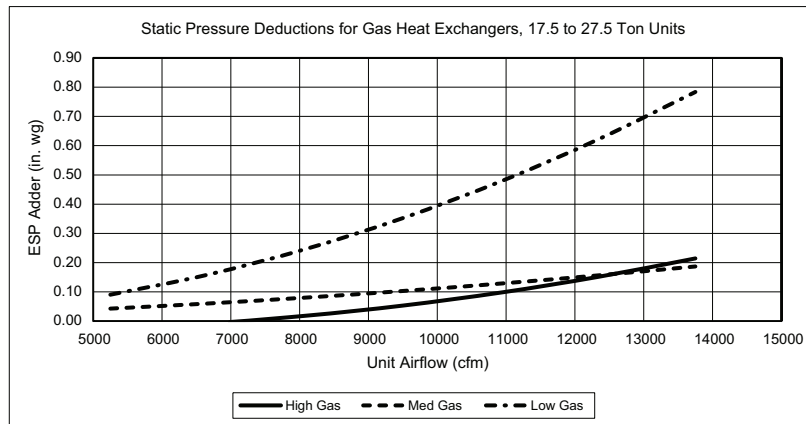

Performance data (cont)

Pressure Drops for Options and Accessories

Economizer Pressure Drop, 17.5 to 27.5 Ton Units

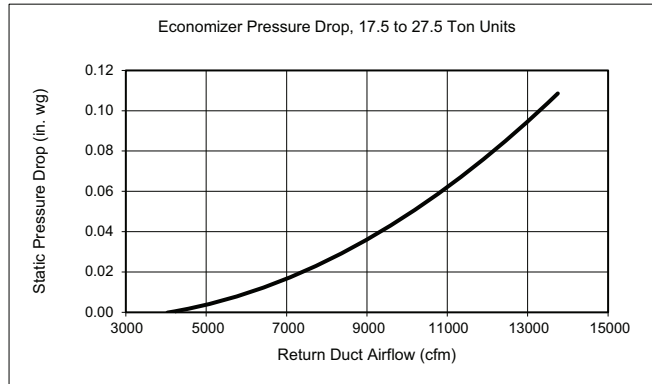

Outside Air Damper Pressure Drop, 17.5 to 27.5 Ton Units

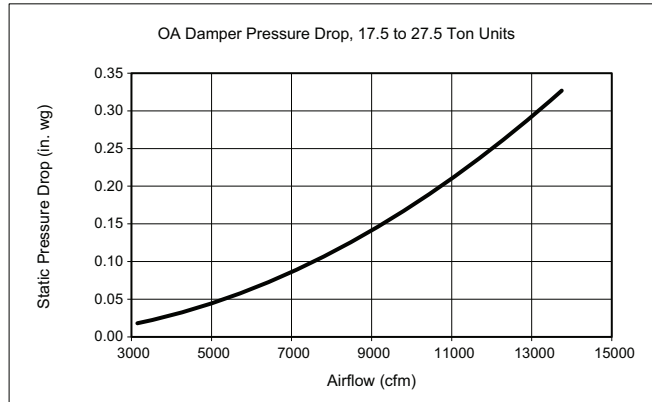

Hot Gas Re-Heat Coil Pressure Drop, 17.5 to 27.5 Ton Units

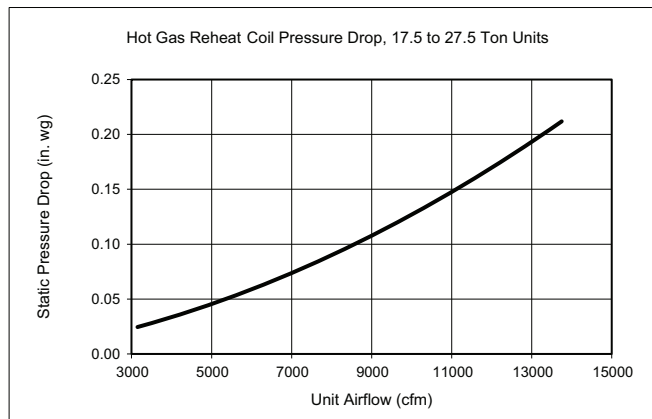

Fan data

General Fan Performance Notes

1. Interpolation is permissible. Do not extrapolate.
2. External static pressure is the static pressure difference between the return duct and the supply duct plus the static pressure caused by any FIOPs or accessories.
3. Tabular data accounts for pressure loss due to clean filters, unit casing, wet coils, and highest gas heat exchanger (when gas heat unit).
4. Factory options and accessories may effect static pressure losses. Gas heat unit fan tables assume highest gas heat models; for fan selections with low or medium heat models, the user must deduct low and medium heat static pressures. Selection software is available, through your salesperson, to help you select the best motor/drive combination for your application.
5. The fan performance tables offer motor/drive recommendations. In cases when 2 motor/drive combinations would work, the lower horsepower option is recommended.
6. For information on the electrical properties of the fan motors, please see the Electrical information section of this book.
7. For more information on the performance limits of the fan motors, see the application data section of this book.
8. The EPACT (Energy Policy Act of 1992) regulates energy requirements for specific types of indoor fan motors. Motors regulated by EPACT include any general purpose, T-frame (3-digit, 143 and larger), single-speed, foot mounted, polyphase, squirrel cage induction motors of NEMA (National Electrical Manufacturers Association) design A and B, manufactured for use in the United States. Ranging from 1 to 200 Hp, these continuous-duty motors operate on 230 and 460 volt, 60 Hz power. If a motor does not fit into these specifications, the motor does not have to be replaced by an EPACT compliant energy-efficient motor. Variable-speed motors are exempt from EPACT compliance requirements.

Fan data (cont)

RGF210 — 17.5 Ton Vertical Supply (rpm - bhp)

CFM	AVAILABLE EXTERNAL STATIC PRESSURE (in. wg)									
	0.2		0.4		0.6		0.8		1.0	
	rpm	bhp	rpm	bhp	rpm	bhp	rpm	bhp	rpm	bhp
5250	1099	1.00	1210	1.33	1313	1.70	1408	2.10	1496	2.51
5690	1172	1.21	1276	1.56	1375	1.96	1466	2.37	1551	2.81
6125	1247	1.46	1344	1.83	1438	2.24	1525	2.67	1607	3.12
6565	1322	1.73	1413	2.12	1502	2.54	1587	3.00	1666	3.47
7000	1399	2.04	1484	2.43	1568	2.87	1649	3.34	1726	3.83
7440	1477	2.37	1556	2.77	1637	3.23	1714	3.70	1788	4.20
7875	1555	2.72	1629	3.13	1705	3.59	1779	4.07	1851	4.59
8315	1633	3.08	1703	3.50	1775	3.96	1846	4.45	1916	4.98
8750	1712	3.46	1778	3.88	1847	4.35	1915	4.84	1981	5.36

CFM	AVAILABLE EXTERNAL STATIC PRESSURE (in. wg)									
	1.2		1.4		1.6		1.8		2.0	
	rpm	bhp	rpm	bhp	rpm	bhp	rpm	bhp	rpm	bhp
5250	1579	2.96	1658	3.42	1733	3.91	1805	4.42	1875	4.95
5690	1631	3.26	1707	3.74	1780	4.24	1851	4.77	1919	5.32
6125	1685	3.60	1759	4.09	1830	4.61	1899	5.15	1965	5.71
6565	1742	3.96	1814	4.48	1883	5.01	1949	5.55	2014	6.13
7000	1800	4.34	1870	4.87	1937	5.41	2002	5.97	—	—
7440	1859	4.73	1927	5.26	1993	5.82	—	—	—	—
7875	1920	5.12	1986	5.67	—	—	—	—	—	—
8315	1982	5.51	2047	6.07	—	—	—	—	—	—
8750	2046	5.91	—	—	—	—	—	—	—	—

Std/Med Static 1099-2000 rpm, 4.8 maximum bhp (2.4 maximum bhp per fan motor)

High Static 1099-2200 rpm, 6.0 maximum bhp (3.0 maximum bhp per fan motor)

RGF210 — Standard/Medium Static — 17.5 Ton Vertical Supply (rpm - vdc)

CFM	AVAILABLE EXTERNAL STATIC PRESSURE (in. wg)									
	0.2		0.4		0.6		0.8		1.0	
	rpm	vdc	rpm	vdc	rpm	vdc	rpm	vdc	rpm	vdc
5250	1099	5.4	1210	5.9	1313	6.5	1408	7.0	1496	7.4
5690	1172	5.7	1276	6.3	1375	6.8	1466	7.3	1551	7.7
6125	1247	6.1	1344	6.6	1438	7.1	1525	7.6	1607	8.0
6565	1322	6.5	1413	7.0	1502	7.4	1587	7.9	1666	8.3
7000	1399	6.9	1484	7.3	1568	7.8	1649	8.2	1726	8.6
7440	1477	7.3	1556	7.7	1637	8.1	1714	8.5	1788	8.9
7875	1555	7.7	1629	8.1	1705	8.5	1779	8.9	1851	9.2
8315	1633	8.1	1703	8.5	1775	8.8	1846	9.2	—	—
8750	1712	8.5	1778	8.9	1847	9.2	—	—	—	—

CFM	AVAILABLE EXTERNAL STATIC PRESSURE (in. wg)									
	1.2		1.4		1.6		1.8		2.0	
	rpm	vdc	rpm	vdc	rpm	vdc	rpm	vdc	rpm	vdc
5250	1579	7.8	1658	8.2	1733	8.6	1805	9.0	—	—
5690	1631	8.1	1707	8.5	1780	8.9	1851	9.2	—	—
6125	1685	8.4	1759	8.8	1830	9.1	—	—	—	—
6565	1742	8.7	1814	9.0	—	—	—	—	—	—
7000	1800	9.0	—	—	—	—	—	—	—	—
7440	1859	9.3	—	—	—	—	—	—	—	—
7875	—	—	—	—	—	—	—	—	—	—
8315	—	—	—	—	—	—	—	—	—	—
8750	—	—	—	—	—	—	—	—	—	—

Std/Med Static 1099-2000 rpm

Fan data (cont)

RGF210 — High Static — 17.5 Ton Vertical Supply (rpm - vdc)

CFM	AVAILABLE EXTERNAL STATIC PRESSURE (in. wg)									
	0.2		0.4		0.6		0.8		1.0	
	rpm	vdc	rpm	vdc	rpm	vdc	rpm	vdc	rpm	vdc
5250	1099	4.9	1210	5.4	1313	5.9	1408	6.3	1496	6.8
5690	1172	5.3	1276	5.7	1375	6.2	1466	6.6	1551	7.0
6125	1247	5.6	1344	6.0	1438	6.5	1525	6.9	1607	7.3
6565	1322	5.9	1413	6.4	1502	6.8	1587	7.2	1666	7.5
7000	1399	6.3	1484	6.7	1568	7.1	1649	7.5	1726	7.8
7440	1477	6.7	1556	7.0	1637	7.4	1714	7.8	1788	8.1
7875	1555	7.0	1629	7.4	1705	7.7	1779	8.1	1851	8.4
8315	1633	7.4	1703	7.7	1775	8.0	1846	8.4	1916	8.7
8750	1712	7.7	1778	8.1	1847	8.4	1915	8.7	1981	9.0

CFM	AVAILABLE EXTERNAL STATIC PRESSURE (in. wg)									
	1.2		1.4		1.6		1.8		2.0	
	rpm	vdc	rpm	vdc	rpm	vdc	rpm	vdc	rpm	vdc
5250	1579	7.1	1658	7.5	1733	7.8	1805	8.2	1875	8.5
5690	1631	7.4	1707	7.7	1780	8.1	1851	8.4	1919	8.7
6125	1685	7.6	1759	8.0	1830	8.3	1899	8.6	1965	8.9
6565	1742	7.9	1814	8.2	1883	8.5	1949	8.8	2014	9.1
7000	1800	8.2	1870	8.5	1937	8.8	2002	9.1	—	—
7440	1859	8.4	1927	8.7	1993	9.0	—	—	—	—
7875	1920	8.7	1986	9.0	—	—	—	—	—	—
8315	1982	9.0	2047	9.3	—	—	—	—	—	—
8750	2046	9.3	—	—	—	—	—	—	—	—

High Static 1099-2200 rpm

Fan data (cont)

RGF240 — 20 Ton Vertical Supply (rpm - bhp)

CFM	AVAILABLE EXTERNAL STATIC PRESSURE (in. wg)									
	0.2		0.4		0.6		0.8		1.0	
	rpm	bhp	rpm	bhp	rpm	bhp	rpm	bhp	rpm	bhp
6,000	1225	1.38	1325	1.75	1419	2.15	1508	2.58	1591	3.03
6,500	1312	1.69	1403	2.07	1493	2.50	1578	2.95	1658	3.42
7,000	1399	2.04	1484	2.43	1568	2.87	1649	3.34	1726	3.83
7,500	1488	2.42	1566	2.82	1646	3.27	1723	3.75	1797	4.26
8,000	1577	2.82	1650	3.23	1725	3.69	1798	4.18	1870	4.70
8,500	1667	3.25	1735	3.66	1806	4.13	1875	4.62	1944	5.15
9,000	1757	3.68	1822	4.10	1888	4.57	1954	5.06	2019	5.58
9,500	1848	4.13	1909	4.55	1971	5.01	2034	5.50	2096	6.02
10,000	1939	4.58	1997	5.00	2056	5.46	2115	5.94	2175	6.47

CFM	AVAILABLE EXTERNAL STATIC PRESSURE (in. wg)									
	1.2		1.4		1.6		1.8		2.0	
	rpm	bhp	rpm	bhp	rpm	bhp	rpm	bhp	rpm	bhp
6,000	1670	3.51	1744	3.99	1816	4.51	1885	5.04	1951	5.59
6,500	1733	3.91	1806	4.42	1875	4.95	1942	5.50	2006	6.06
7,000	1800	4.34	1870	4.87	1937	5.41	2002	5.97	2064	6.55
7,500	1868	4.78	1936	5.33	2001	5.88	2064	6.45	2125	7.04
8,000	1938	5.24	2004	5.79	2067	6.35	2128	6.93	2187	7.52
8,500	2010	5.69	2073	6.24	2135	6.82	2194	7.40	—	—
9,000	2083	6.13	2144	6.69	—	—	—	—	—	—
9,500	2157	6.56	—	—	—	—	—	—	—	—
10,000	—	—	—	—	—	—	—	—	—	—

Std/Med Static 1225-2000 rpm, 4.8 maximum bhp (2.4 maximum bhp per fan motor)

High Static 1225-2200 rpm, 10.0 maximum bhp (5.0 maximum bhp per fan motor)

RGF240 — Standard/Medium Static — 20 Ton Vertical Supply (rpm - vdc)

CFM	AVAILABLE EXTERNAL STATIC PRESSURE (in. wg)									
	0.2		0.4		0.6		0.8		1.0	
	rpm	vdc	rpm	vdc	rpm	vdc	rpm	vdc	rpm	vdc
6,000	1225	5.5	1325	6.0	1419	6.4	1508	6.8	1591	7.2
6,500	1312	5.9	1403	6.3	1493	6.7	1578	7.1	1658	7.5
7,000	1399	6.3	1484	6.7	1568	7.1	1649	7.5	1726	7.8
7,500	1488	6.7	1566	7.1	1646	7.4	1723	7.8	1797	8.1
8,000	1577	7.1	1650	7.5	1725	7.8	1798	8.1	1870	8.5
8,500	1667	7.5	1735	7.9	1806	8.2	1875	8.5	—	—
9,000	1757	8.0	1822	8.3	1888	8.6	—	—	—	—
9,500	1848	8.4	1909	8.7	—	—	—	—	—	—
10,000	1939	8.8	—	—	—	—	—	—	—	—

CFM	AVAILABLE EXTERNAL STATIC PRESSURE (in. wg)									
	1.2		1.4		1.6		1.8		2.0	
	rpm	vdc	rpm	vdc	rpm	vdc	rpm	vdc	rpm	vdc
6,000	1670	7.6	1744	7.9	1816	8.2	—	—	—	—
6,500	1733	7.8	1806	8.2	—	—	—	—	—	—
7,000	1800	8.2	—	—	—	—	—	—	—	—
7,500	1868	8.5	—	—	—	—	—	—	—	—
8,000	—	—	—	—	—	—	—	—	—	—
8,500	—	—	—	—	—	—	—	—	—	—
9,000	—	—	—	—	—	—	—	—	—	—
9,500	—	—	—	—	—	—	—	—	—	—
10,000	—	—	—	—	—	—	—	—	—	—

Std/Med Static 1225-2000 rpm

Fan data (cont)

RGF240 — High Static — 20 Ton Vertical Supply (rpm - vdc)

CFM	AVAILABLE EXTERNAL STATIC PRESSURE (in. wg)									
	0.2		0.4		0.6		0.8		1.0	
	rpm	vdc	rpm	vdc	rpm	vdc	rpm	vdc	rpm	vdc
6,000	1225	5.5	1325	6.0	1419	6.4	1508	6.8	1591	7.2
6,500	1312	5.9	1403	6.3	1493	6.7	1578	7.1	1658	7.5
7,000	1399	6.3	1484	6.7	1568	7.1	1649	7.5	1726	7.8
7,500	1488	6.7	1566	7.1	1646	7.4	1723	7.8	1797	8.1
8,000	1577	7.1	1650	7.5	1725	7.8	1798	8.1	1870	8.5
8,500	1667	7.5	1735	7.9	1806	8.2	1875	8.5	1944	8.8
9,000	1757	8.0	1822	8.3	1888	8.6	1954	8.9	2019	9.2
9,500	1848	8.4	1909	8.7	1971	8.9	2034	9.2	2096	9.5
10,000	1939	8.8	1997	9.1	2056	9.3	2115	9.6	2175	9.9

CFM	AVAILABLE EXTERNAL STATIC PRESSURE (in. wg)									
	1.2		1.4		1.6		1.8		2.0	
	rpm	vdc	rpm	vdc	rpm	vdc	rpm	vdc	rpm	vdc
6,000	1670	7.6	1744	7.9	1816	8.2	1885	8.5	1951	8.9
6,500	1733	7.8	1806	8.2	1875	8.5	1942	8.8	2006	9.1
7,000	1800	8.2	1870	8.5	1937	8.8	2002	9.1	2064	9.4
7,500	1868	8.5	1936	8.8	2001	9.1	2064	9.4	2125	9.7
8,000	1938	8.8	2004	9.1	2067	9.4	2128	9.7	2187	9.9
8,500	2010	9.1	2073	9.4	2135	9.7	2194	10.0	—	—
9,000	2083	9.5	2144	9.7	—	—	—	—	—	—
9,500	2157	9.8	—	—	—	—	—	—	—	—
10,000	—	—	—	—	—	—	—	—	—	—

High Static 1225-2200 rpm

Fan data (cont)

RGF300 — 25 Ton Vertical Supply (rpm - bhp)

CFM	AVAILABLE EXTERNAL STATIC PRESSURE (in. wg)									
	0.2		0.4		0.6		0.8		1.0	
	rpm	bhp	rpm	bhp	rpm	bhp	rpm	bhp	rpm	bhp
7,500	1184	1.59	1267	1.95	1355	2.39	1444	2.89	1531	3.44
8,125	1270	1.98	1345	2.35	1425	2.80	1507	3.31	1590	3.89
8,750	1357	2.43	1425	2.81	1498	3.26	1574	3.79	1651	4.37
9,375	1444	2.92	1508	3.33	1575	3.79	1644	4.31	1715	4.89
10,000	1533	3.46	1592	3.88	1653	4.34	1718	4.88	1784	5.46
10,625	1621	4.03	1676	4.45	1734	4.93	1794	5.46	1855	6.04
11,250	1711	4.64	1762	5.07	1816	5.55	1871	6.07	1929	6.65
11,875	1800	5.30	1849	5.75	1899	6.23	1951	6.75	2005	7.33
12,500	1890	6.10	1936	6.56	1983	7.05	2032	7.58	2083	8.17

CFM	AVAILABLE EXTERNAL STATIC PRESSURE (in. wg)									
	1.2		1.4		1.6		1.8		2.0	
	rpm	bhp	rpm	bhp	rpm	bhp	rpm	bhp	rpm	bhp
7,500	1614	4.04	1693	4.66	1766	5.29	1837	5.95	1903	6.61
8,125	1669	4.49	1746	5.15	1818	5.81	1888	6.51	1954	7.21
8,750	1727	5.00	1801	5.67	1872	6.37	1940	7.09	2005	7.83
9,375	1787	5.53	1858	6.22	1927	6.94	1994	7.69	2058	8.45
10,000	1851	6.10	1918	6.78	1985	7.52	2049	8.27	2112	9.06
10,625	1918	6.68	1981	7.36	2044	8.08	2107	8.85	2167	9.63
11,250	1987	7.27	2047	7.95	2107	8.67	2166	9.42	—	—
11,875	2060	7.95	2116	8.62	2172	9.32	—	—	—	—
12,500	2134	8.78	2187	9.45	—	—	—	—	—	—

Std/Med Static 1184-2000 rpm, 6.0 maximum bhp (3.0 maximum bhp per fan motor)

High Static 1184-2200 rpm, 10.0 maximum bhp (5.0 maximum bhp per fan motor)

RGF300 — Standard/Medium Static — 25 Ton Vertical Supply (rpm - vdc)

CFM	AVAILABLE EXTERNAL STATIC PRESSURE (in. wg)									
	0.2		0.4		0.6		0.8		1.0	
	rpm	vdc	rpm	vdc	rpm	vdc	rpm	vdc	rpm	vdc
7,500	1184	5.3	1267	5.7	1355	6.1	1444	6.5	1531	6.9
8,125	1270	5.7	1345	6.1	1425	6.4	1507	6.8	1590	7.2
8,750	1357	6.1	1425	6.4	1498	6.8	1574	7.1	1651	7.5
9,375	1444	6.5	1508	6.8	1575	7.1	1644	7.4	1715	7.8
10,000	1533	6.9	1592	7.2	1653	7.5	1718	7.8	1784	8.1
10,625	1621	7.3	1676	7.6	1734	7.8	1794	8.1	—	—
11,250	1711	7.7	1762	8.0	1816	8.2	—	—	—	—
11,875	1800	8.2	1849	8.4	—	—	—	—	—	—
12,500	—	—	—	—	—	—	—	—	—	—

CFM	AVAILABLE EXTERNAL STATIC PRESSURE (in. wg)									
	1.2		1.4		1.6		1.8		2.0	
	rpm	vdc	rpm	vdc	rpm	vdc	rpm	vdc	rpm	vdc
7,500	1614	7.3	1693	7.7	1766	8.0	1837	8.3	—	—
8,125	1669	7.5	1746	7.9	1818	8.2	—	—	—	—
8,750	1727	7.8	1801	8.2	—	—	—	—	—	—
9,375	1787	8.1	1858	8.4	—	—	—	—	—	—
10,000	—	—	—	—	—	—	—	—	—	—
10,625	—	—	—	—	—	—	—	—	—	—
11,250	—	—	—	—	—	—	—	—	—	—
11,875	—	—	—	—	—	—	—	—	—	—
12,500	—	—	—	—	—	—	—	—	—	—

Std/Med Static 1184-2000 rpm

Fan data (cont)

RGF300 — High Static — 25 Ton Vertical Supply (rpm - vdc)

CFM	AVAILABLE EXTERNAL STATIC PRESSURE (in. wg)									
	0.2		0.4		0.6		0.8		1.0	
	rpm	vdc	rpm	vdc	rpm	vdc	rpm	vdc	rpm	vdc
7,500	1184	5.3	1267	5.7	1355	6.1	1444	6.5	1531	6.9
8,125	1270	5.7	1345	6.1	1425	6.4	1507	6.8	1590	7.2
8,750	1357	6.1	1425	6.4	1498	6.8	1574	7.1	1651	7.5
9,375	1444	6.5	1508	6.8	1575	7.1	1644	7.4	1715	7.8
10,000	1533	6.9	1592	7.2	1653	7.5	1718	7.8	1784	8.1
10,625	1621	7.3	1676	7.6	1734	7.8	1794	8.1	1855	8.4
11,250	1711	7.7	1762	8.0	1816	8.2	1871	8.5	1929	8.7
11,875	1800	8.2	1849	8.4	1899	8.6	1951	8.9	2005	9.1
12,500	1890	8.6	1936	8.8	1983	9.0	2032	9.2	2083	9.5

CFM	AVAILABLE EXTERNAL STATIC PRESSURE (in. wg)									
	1.2		1.4		1.6		1.8		2.0	
	rpm	vdc	rpm	vdc	rpm	vdc	rpm	vdc	rpm	vdc
7,500	1614	7.3	1693	7.7	1766	8.0	1837	8.3	1903	8.6
8,125	1669	7.5	1746	7.9	1818	8.2	1888	8.6	1954	8.9
8,750	1727	7.8	1801	8.2	1872	8.5	1940	8.8	2005	9.1
9,375	1787	8.1	1858	8.4	1927	8.7	1994	9.0	2058	9.3
10,000	1851	8.4	1918	8.7	1985	9.0	2049	9.3	2112	9.6
10,625	1918	8.7	1981	9.0	2044	9.3	2107	9.6	2167	9.8
11,250	1987	9.0	2047	9.3	2107	9.6	2166	9.8	—	—
11,875	2060	9.4	2116	9.6	2172	9.9	—	—	—	—
12,500	2134	9.7	2187	9.9	—	—	—	—	—	—

High Static 1184-2200 rpm

Fan data (cont)

RGF336 — 27.5 Ton Vertical Supply (rpm - bhp)

CFM	AVAILABLE EXTERNAL STATIC PRESSURE (in. wg)									
	0.2		0.4		0.6		0.8		1.0	
	rpm	bhp	rpm	bhp	rpm	bhp	rpm	bhp	rpm	bhp
8,250	1280	2.03	1353	2.40	1431	2.84	1512	3.35	1593	3.91
8,940	1376	2.53	1442	2.91	1513	3.36	1586	3.88	1661	4.45
9,625	1472	3.09	1533	3.49	1597	3.94	1664	4.46	1733	5.03
10,300	1569	3.69	1625	4.10	1684	4.56	1746	5.08	1809	5.65
11,000	1666	4.32	1719	4.75	1773	5.21	1830	5.73	1888	6.29
11,700	1764	5.02	1813	5.45	1864	5.92	1917	6.44	1971	7.00
12,375	1863	5.84	1909	6.28	1956	6.76	2005	7.28	2056	7.85
13,075	1961	6.94	2005	7.41	2049	7.91	2095	8.46	2142	9.04
13,750	2060	8.64	2101	9.17	2143	9.73	—	—	—	—

CFM	AVAILABLE EXTERNAL STATIC PRESSURE (in. wg)									
	1.2		1.4		1.6		1.8		2.0	
	rpm	bhp	rpm	bhp	rpm	bhp	rpm	bhp	rpm	bhp
8,250	1672	4.52	1748	5.17	1821	5.84	1890	6.53	1957	7.25
8,940	1736	5.08	1809	5.75	1879	6.44	1947	7.17	2012	7.91
9,625	1803	5.67	1872	6.35	1940	7.06	2006	7.81	2070	8.58
10,300	1874	6.28	1939	6.96	2004	7.68	2067	8.43	2129	9.21
11,000	1948	6.91	2009	7.58	2070	8.29	2131	9.05	2190	9.82
11,700	2026	7.60	2083	8.26	2140	8.96	2198	9.71	—	—
12,375	2107	8.45	2160	9.10	—	—	—	—	—	—
13,075	2191	9.67	—	—	—	—	—	—	—	—
13,750	—	—	—	—	—	—	—	—	—	—

Std/Med Static 1280-2200 rpm, 6.0 maximum bhp (3.0 maximum bhp per fan motor)

High Static 1280-2200 rpm, 10.0 maximum bhp (5 maximum bhp per fan motor)

RGF336 — Standard/Medium Static — 27.5 Ton Vertical Supply (rpm - vdc)

CFM	AVAILABLE EXTERNAL STATIC PRESSURE (in. wg)									
	0.2		0.4		0.6		0.8		1.0	
	rpm	vdc	rpm	vdc	rpm	vdc	rpm	vdc	rpm	vdc
8,250	1280	5.8	1353	6.1	1431	6.5	1512	6.8	1593	7.2
8,940	1376	6.2	1442	6.5	1513	6.8	1586	7.2	1661	7.5
9,625	1472	6.6	1533	6.9	1597	7.2	1664	7.5	1733	7.8
10,300	1569	7.1	1625	7.3	1684	7.6	1746	7.9	1809	8.2
11,000	1666	7.5	1719	7.8	1773	8.0	1830	8.3	—	—
11,700	1764	8.0	1813	8.2	1864	8.4	—	—	—	—
12,375	1863	8.4	—	—	—	—	—	—	—	—
13,075	—	—	—	—	—	—	—	—	—	—
13,750	—	—	—	—	—	—	—	—	—	—

CFM	AVAILABLE EXTERNAL STATIC PRESSURE (in. wg)									
	1.2		1.4		1.6		1.8		2.0	
	rpm	vdc	rpm	vdc	rpm	vdc	rpm	vdc	rpm	vdc
8,250	1672	7.6	1748	7.9	1821	8.3	—	—	—	—
8,940	1736	7.9	1809	8.2	—	—	—	—	—	—
9,625	1803	8.2	—	—	—	—	—	—	—	—
10,300	—	—	—	—	—	—	—	—	—	—
11,000	—	—	—	—	—	—	—	—	—	—
11,700	—	—	—	—	—	—	—	—	—	—
12,375	—	—	—	—	—	—	—	—	—	—
13,075	—	—	—	—	—	—	—	—	—	—
13,750	—	—	—	—	—	—	—	—	—	—

Std/Med Static 1280-2200 rpm

Fan data (cont)

RGF336 — High Static — 27.5 Ton Vertical Supply (rpm - vdc)

CFM	AVAILABLE EXTERNAL STATIC PRESSURE (in. wg)									
	0.2		0.4		0.6		0.8		1.0	
	rpm	vdc	rpm	vdc	rpm	vdc	rpm	vdc	rpm	vdc
8,250	1280	5.8	1353	6.1	1431	6.5	1512	6.8	1593	7.2
8,940	1376	6.2	1442	6.5	1513	6.8	1586	7.2	1661	7.5
9,625	1472	6.6	1533	6.9	1597	7.2	1664	7.5	1733	7.8
10,300	1569	7.1	1625	7.3	1684	7.6	1746	7.9	1809	8.2
11,000	1666	7.5	1719	7.8	1773	8.0	1830	8.3	1888	8.6
11,700	1764	8.0	1813	8.2	1864	8.4	1917	8.7	1971	8.9
12,375	1863	8.4	1909	8.7	1956	8.9	2005	9.1	2056	9.3
13,075	1961	8.9	2005	9.1	2049	9.3	2095	9.5	2142	9.7
13,750	2060	9.4	2101	9.5	2143	9.7	2186	9.9	—	—

CFM	AVAILABLE EXTERNAL STATIC PRESSURE (in. wg)									
	1.2		1.4		1.6		1.8		2.0	
	rpm	vdc	rpm	vdc	rpm	vdc	rpm	vdc	rpm	vdc
8,250	1672	7.6	1748	7.9	1821	8.3	1890	8.6	1957	8.9
8,940	1736	7.9	1809	8.2	1879	8.5	1947	8.8	2012	9.1
9,625	1803	8.2	1872	8.5	1940	8.8	2006	9.1	2070	9.4
10,300	1874	8.5	1939	8.8	2004	9.1	2067	9.4	2129	9.7
11,000	1948	8.8	2009	9.1	2070	9.4	2131	9.7	2190	10.0
11,700	2026	9.2	2083	9.5	2140	9.7	2198	10.0	—	—
12,375	2107	9.6	2160	9.8	—	—	—	—	—	—
13,075	2191	10.0	—	—	—	—	—	—	—	—
13,750	—	—	—	—	—	—	—	—	—	—

High Static 1280-2200 rpm

Fan data (cont)

RGF210 — 17.5 Ton Horizontal Supply (rpm - bhp)

CFM	AVAILABLE EXTERNAL STATIC PRESSURE (in. wg)									
	0.2		0.4		0.6		0.8		1.0	
	rpm	bhp	rpm	bhp	rpm	bhp	rpm	bhp	rpm	bhp
5250	1237	1.14	1337	1.43	1432	1.76	1522	2.11	1607	2.49
5690	1323	1.38	1417	1.69	1506	2.03	1592	2.40	1673	2.79
6125	1411	1.66	1499	1.99	1583	2.34	1664	2.72	1742	3.12
6560	1499	1.96	1582	2.30	1661	2.66	1738	3.05	1813	3.47
7000	1589	2.29	1666	2.64	1742	3.02	1815	3.42	1886	3.84
7440	1678	2.65	1752	3.02	1823	3.40	1893	3.81	1961	4.23
7875	1768	3.04	1838	3.42	1906	3.81	1973	4.23	2038	4.66
8310	1859	3.46	1925	3.85	1990	4.25	2054	4.67	2116	5.11
8750	1950	3.91	2013	4.30	2075	4.71	2136	5.14	2196	5.59

CFM	AVAILABLE EXTERNAL STATIC PRESSURE (in. wg)									
	1.2		1.4		1.6		1.8		2.0	
	rpm	bhp	rpm	bhp	rpm	bhp	rpm	bhp	rpm	bhp
5250	1688	2.88	1764	3.29	1837	3.72	1908	4.17	1976	4.63
5690	1751	3.20	1825	3.62	1896	4.06	1965	4.52	2031	4.99
6125	1817	3.54	1889	3.97	1958	4.43	2024	4.89	2088	5.37
6560	1885	3.89	1954	4.34	2021	4.80	2086	5.28	2148	5.76
7000	1955	4.27	2022	4.73	2087	5.20	2150	5.68	—	—
7440	2027	4.67	2092	5.14	2154	5.61	—	—	—	—
7875	2101	5.10	2163	5.57	—	—	—	—	—	—
8310	2177	5.56	—	—	—	—	—	—	—	—
8750	—	—	—	—	—	—	—	—	—	—

High Static 1237-2200 rpm, 10.0 maximum bhp (5.0 maximum bhp per fan motor)

RGF210 — High Static — 17.5 ton Horizontal Supply (rpm - vdc)

CFM	AVAILABLE EXTERNAL STATIC PRESSURE (in. wg)									
	0.2		0.4		0.6		0.8		1.0	
	rpm	vdc	rpm	vdc	rpm	vdc	rpm	vdc	rpm	vdc
5250	1237	5.6	1337	6.0	1432	6.5	1522	6.9	1607	7.3
5690	1323	6.0	1417	6.4	1506	6.8	1592	7.2	1673	7.6
6125	1411	6.4	1499	6.8	1583	7.2	1664	7.5	1742	7.9
6560	1499	6.8	1582	7.1	1661	7.5	1738	7.9	1813	8.2
7000	1589	7.2	1666	7.5	1742	7.9	1815	8.2	1886	8.6
7440	1678	7.6	1752	7.9	1823	8.3	1893	8.6	1961	8.9
7875	1768	8.0	1838	8.3	1906	8.6	1973	9.0	2038	9.3
8310	1859	8.4	1925	8.7	1990	9.0	2054	9.3	2116	9.6
8750	1950	8.8	2013	9.1	2075	9.4	2136	9.7	2196	10.0

CFM	AVAILABLE EXTERNAL STATIC PRESSURE (in. wg)									
	1.2		1.4		1.6		1.8		2.0	
	rpm	vdc	rpm	vdc	rpm	vdc	rpm	vdc	rpm	vdc
5250	1688	7.6	1764	8.0	1837	8.3	1908	8.7	1976	9.0
5690	1751	7.9	1825	8.3	1896	8.6	1965	8.9	2031	9.2
6125	1817	8.2	1889	8.6	1958	8.9	2024	9.2	2088	9.5
6560	1885	8.5	1954	8.9	2021	9.2	2086	9.5	2148	9.8
7000	1955	8.9	2022	9.2	2087	9.5	2150	9.8	—	—
7440	2027	9.2	2092	9.5	2154	9.8	—	—	—	—
7875	2101	9.5	2163	9.8	—	—	—	—	—	—
8310	2177	9.9	—	—	—	—	—	—	—	—
8750	—	—	—	—	—	—	—	—	—	—

High Static 1237-2200 rpm

Fan data (cont)

RGF240 — 20 Ton Horizontal Supply (rpm - bhp)

CFM	AVAILABLE EXTERNAL STATIC PRESSURE (in. wg)									
	0.2		0.4		0.6		0.8		1.0	
	rpm	bhp	rpm	bhp	rpm	bhp	rpm	bhp	rpm	bhp
6,000	1386	1.58	1475	1.90	1561	2.25	1643	2.62	1722	3.02
6,500	1487	1.92	1570	2.26	1650	2.62	1728	3.01	1803	3.42
7,000	1589	2.29	1666	2.64	1742	3.02	1815	3.42	1886	3.84
7,500	1691	2.71	1764	3.07	1835	3.46	1904	3.86	1972	4.29
8,000	1794	3.16	1863	3.54	1930	3.93	1996	4.35	2060	4.78
8,500	1898	3.65	1963	4.04	2026	4.44	2089	4.87	2150	5.31
9,000	2002	4.18	2064	4.58	2124	4.99	2183	5.41	—	—
9,500	2106	4.70	2165	5.11	—	—	—	—	—	—
10,000	—	—	—	—	—	—	—	—	—	—

CFM	AVAILABLE EXTERNAL STATIC PRESSURE (in. wg)									
	1.2		1.4		1.6		1.8		2.0	
	rpm	bhp	rpm	bhp	rpm	bhp	rpm	bhp	rpm	bhp
6,000	1798	3.44	1870	3.87	1940	4.32	2007	4.78	2072	5.26
6,500	1875	3.84	1945	4.29	2012	4.75	2077	5.22	2140	5.71
7,000	1955	4.27	2022	4.73	2087	5.20	2150	5.68	—	—
7,500	2038	4.74	2102	5.20	2164	5.67	—	—	—	—
8,000	2123	5.23	2184	5.70	—	—	—	—	—	—
8,500	—	—	—	—	—	—	—	—	—	—
9,000	—	—	—	—	—	—	—	—	—	—
9,500	—	—	—	—	—	—	—	—	—	—
10,000	—	—	—	—	—	—	—	—	—	—

High Static 1386-2200 rpm, 10.0 maximum bhp (5.0 maximum bhp per fan motor)

RGF240 — High Static — 20 Ton Horizontal Supply (rpm - vdc)

CFM	AVAILABLE EXTERNAL STATIC PRESSURE (in. wg)									
	0.2		0.4		0.6		0.8		1.0	
	rpm	vdc	rpm	vdc	rpm	vdc	rpm	vdc	rpm	vdc
6,000	1386	6.2	1475	6.7	1561	7.1	1643	7.4	1722	7.8
6,500	1487	6.7	1570	7.1	1650	7.5	1728	7.8	1803	8.2
7,000	1589	7.2	1666	7.5	1742	7.9	1815	8.2	1886	8.6
7,500	1691	7.7	1764	8.0	1835	8.3	1904	8.6	1972	8.9
8,000	1794	8.1	1863	8.4	1930	8.8	1996	9.1	2060	9.4
8,500	1898	8.6	1963	8.9	2026	9.2	2089	9.5	2150	9.8
9,000	2002	9.1	2064	9.4	2124	9.6	2183	9.9	—	—
9,500	2106	9.6	2165	9.8	—	—	—	—	—	—
10,000	—	—	—	—	—	—	—	—	—	—

CFM	AVAILABLE EXTERNAL STATIC PRESSURE (in. wg)									
	1.2		1.4		1.6		1.8		2.0	
	rpm	vdc	rpm	vdc	rpm	vdc	rpm	vdc	rpm	vdc
6,000	1798	8.1	1870	8.5	1940	8.8	2007	9.1	2072	9.4
6,500	1875	8.5	1945	8.8	2012	9.1	2077	9.4	2140	9.7
7,000	1955	8.9	2022	9.2	2087	9.5	2150	9.8	—	—
7,500	2038	9.3	2102	9.5	2164	9.8	—	—	—	—
8,000	2123	9.6	2184	9.9	—	—	—	—	—	—
8,500	—	—	—	—	—	—	—	—	—	—
9,000	—	—	—	—	—	—	—	—	—	—
9,500	—	—	—	—	—	—	—	—	—	—
10,000	—	—	—	—	—	—	—	—	—	—

High Static 1386-2200 rpm

Fan data (cont)

RGF300 — 25 Ton Horizontal Supply (rpm - bhp)

CFM	AVAILABLE EXTERNAL STATIC PRESSURE (in. wg)									
	0.2		0.4		0.6		0.8		1.0	
	rpm	bhp	rpm	bhp	rpm	bhp	rpm	bhp	rpm	bhp
7,500	1494	2.53	1571	2.94	1648	3.39	1722	3.87	1795	4.38
8,125	1606	3.13	1678	3.57	1748	4.04	1818	4.54	1886	5.07
8,750	1719	3.82	1786	4.28	1852	4.77	1917	5.29	1981	5.84
9,375	1833	4.58	1895	5.06	1957	5.57	2018	6.11	2078	6.67
10,000	1947	5.41	2005	5.90	2063	6.43	2121	6.99	2178	7.57
10,625	2062	6.29	2117	6.81	2171	7.35	—	—	—	—
11,250	2177	7.22	—	—	—	—	—	—	—	—
11,875	—	—	—	—	—	—	—	—	—	—
12,500	—	—	—	—	—	—	—	—	—	—

CFM	AVAILABLE EXTERNAL STATIC PRESSURE (in. wg)									
	1.2		1.4		1.6		1.8		2.0	
	rpm	bhp	rpm	bhp	rpm	bhp	rpm	bhp	rpm	bhp
7,500	1864	4.91	1931	5.46	1996	6.03	2058	6.61	2117	7.19
8,125	1953	5.63	2017	6.20	2079	6.79	2139	7.40	2197	8.02
8,750	2044	6.41	2105	7.01	2165	7.62	—	—	—	—
9,375	2138	7.26	2197	7.88	—	—	—	—	—	—
10,000	—	—	—	—	—	—	—	—	—	—
10,625	—	—	—	—	—	—	—	—	—	—
11,250	—	—	—	—	—	—	—	—	—	—
11,875	—	—	—	—	—	—	—	—	—	—
12,500	—	—	—	—	—	—	—	—	—	—

High Static 1494-2200 rpm, 10.0 maximum bhp (5.0 maximum bhp per fan motor)

RGF300 — High Static — 25 Ton Horizontal Supply (rpm - vdc)

CFM	AVAILABLE EXTERNAL STATIC PRESSURE (in. wg)									
	0.2		0.4		0.6		0.8		1.0	
	rpm	vdc	rpm	vdc	rpm	vdc	rpm	vdc	rpm	vdc
7,500	1494	6.7	1571	7.1	1648	7.5	1722	7.8	1795	8.1
8,125	1606	7.3	1678	7.6	1748	7.9	1818	8.2	1886	8.6
8,750	1719	7.8	1786	8.1	1852	8.4	1917	8.7	1981	9.0
9,375	1833	8.3	1895	8.6	1957	8.9	2018	9.2	2078	9.4
10,000	1947	8.8	2005	9.1	2063	9.4	2121	9.6	2178	9.9
10,625	2062	9.4	2117	9.6	2171	9.9	—	—	—	—
11,250	2177	9.9	—	—	—	—	—	—	—	—
11,875	—	—	—	—	—	—	—	—	—	—
12,500	—	—	—	—	—	—	—	—	—	—

CFM	AVAILABLE EXTERNAL STATIC PRESSURE (in. wg)									
	1.2		1.4		1.6		1.8		2.0	
	rpm	vdc	rpm	vdc	rpm	vdc	rpm	vdc	rpm	vdc
7,500	1864	8.4	1931	8.8	1996	9.1	2058	9.3	2117	9.6
8,125	1953	8.9	2017	9.2	2079	9.4	2139	9.7	2197	10.0
8,750	2044	9.3	2105	9.6	2165	9.8	—	—	—	—
9,375	2138	9.7	2197	10.0	—	—	—	—	—	—
10,000	—	—	—	—	—	—	—	—	—	—
10,625	—	—	—	—	—	—	—	—	—	—
11,250	—	—	—	—	—	—	—	—	—	—
11,875	—	—	—	—	—	—	—	—	—	—
12,500	—	—	—	—	—	—	—	—	—	—

High Static 1494-2200 rpm

Fan data (cont)

RGF336 — 27.5 Ton Horizontal Supply (rpm - bhp)

CFM	AVAILABLE EXTERNAL STATIC PRESSURE (in. wg)									
	0.2		0.4		0.6		0.8		1.0	
	rpm	bhp	rpm	bhp	rpm	bhp	rpm	bhp	rpm	bhp
8,250	1619	3.20	1689	3.64	1759	4.11	1828	4.61	1896	5.15
8,940	1743	3.97	1808	4.43	1872	4.91	1936	5.44	2000	5.99
9,625	1868	4.82	1928	5.30	1987	5.80	2048	6.35	2107	6.92
10,300	1993	5.74	2049	6.24	2105	6.77	2161	7.32	—	—
11,000	2119	6.73	2171	7.24	—	—	—	—	—	—
11,690	—	—	—	—	—	—	—	—	—	—
12,375	—	—	—	—	—	—	—	—	—	—
13,060	—	—	—	—	—	—	—	—	—	—
13,750	—	—	—	—	—	—	—	—	—	—

CFM	AVAILABLE EXTERNAL STATIC PRESSURE (in. wg)									
	1.2		1.4		1.6		1.8		2.0	
	rpm	bhp	rpm	bhp	rpm	bhp	rpm	bhp	rpm	bhp
8,250	1961	5.70	2025	6.27	2087	6.86	2147	7.47	—	—
8,940	2062	6.57	2122	7.16	2182	7.78	—	—	—	—
9,625	2165	7.50	—	—	—	—	—	—	—	—
10,300	—	—	—	—	—	—	—	—	—	—
11,000	—	—	—	—	—	—	—	—	—	—
11,690	—	—	—	—	—	—	—	—	—	—
12,375	—	—	—	—	—	—	—	—	—	—
13,060	—	—	—	—	—	—	—	—	—	—
13,750	—	—	—	—	—	—	—	—	—	—

High Static 1619-2200 rpm, 10.0 maximum bhp (maximum bhp 5.0 per fan motor)

RGF336 — High Static — 27.5 Ton Horizontal Supply (rpm - vdc)

CFM	AVAILABLE EXTERNAL STATIC PRESSURE (in. wg)									
	0.2		0.4		0.6		0.8		1.0	
	rpm	vdc	rpm	vdc	rpm	vdc	rpm	vdc	rpm	vdc
8,250	1619	7.3	1689	7.6	1759	8.0	1828	8.3	1896	8.6
8,940	1743	7.9	1808	8.2	1872	8.5	1936	8.8	2000	9.1
9,625	1868	8.5	1928	8.7	1987	9.0	2048	9.3	2107	9.6
10,300	1993	9.0	2049	9.3	2105	9.6	2161	9.8	—	—
11,000	2119	9.6	2171	9.9	—	—	—	—	—	—
11,690	—	—	—	—	—	—	—	—	—	—
12,375	—	—	—	—	—	—	—	—	—	—
13,060	—	—	—	—	—	—	—	—	—	—
13,750	—	—	—	—	—	—	—	—	—	—

CFM	AVAILABLE EXTERNAL STATIC PRESSURE (in. wg)									
	1.2		1.4		1.6		1.8		2.0	
	rpm	vdc	rpm	vdc	rpm	vdc	rpm	vdc	rpm	vdc
8,250	1961	8.9	2025	9.2	2087	9.5	2147	9.8	—	—
8,940	2062	9.4	2122	9.6	2182	9.9	—	—	—	—
9,625	2165	9.8	—	—	—	—	—	—	—	—
10,300	—	—	—	—	—	—	—	—	—	—
11,000	—	—	—	—	—	—	—	—	—	—
11,690	—	—	—	—	—	—	—	—	—	—
12,375	—	—	—	—	—	—	—	—	—	—
13,060	—	—	—	—	—	—	—	—	—	—
13,750	—	—	—	—	—	—	—	—	—	—

High Static 1619-2200 rpm

Fan data (cont)

RAF210 — 17.5 Ton Vertical Supply (rpm - bhp)

CFM	AVAILABLE EXTERNAL STATIC PRESSURE (in. wg)									
	0.2		0.4		0.6		0.8		1.0	
	rpm	bhp	rpm	bhp	rpm	bhp	rpm	bhp	rpm	bhp
5250	1048	0.86	1162	1.18	1268	1.53	1366	1.91	1457	2.32
5690	1116	1.05	1220	1.37	1322	1.74	1417	2.14	1505	2.56
6125	1185	1.25	1281	1.58	1377	1.96	1469	2.39	1555	2.83
6565	1257	1.49	1344	1.82	1435	2.22	1523	2.65	1606	3.11
7000	1329	1.75	1409	2.08	1494	2.48	1578	2.92	1658	3.39
7440	1401	2.02	1475	2.36	1555	2.77	1635	3.21	1712	3.69
7875	1475	2.32	1543	2.66	1617	3.06	1693	3.51	1768	4.00
8315	1549	2.63	1612	2.97	1681	3.36	1753	3.81	1825	4.30
8750	1623	2.95	1682	3.28	1747	3.68	1815	4.12	1883	4.61

CFM	AVAILABLE EXTERNAL STATIC PRESSURE (in. wg)									
	1.2		1.4		1.6		1.8		2.0	
	rpm	bhp	rpm	bhp	rpm	bhp	rpm	bhp	rpm	bhp
5250	1543	2.76	1623	3.21	1700	3.69	1773	4.18	1844	4.71
5690	1588	3.01	1666	3.48	1741	3.97	1813	4.48	1882	5.02
6125	1635	3.29	1712	3.78	1785	4.28	1855	4.80	1922	5.34
6565	1684	3.58	1759	4.08	1830	4.60	1899	5.14	1965	5.69
7000	1735	3.89	1808	4.40	1877	4.92	1944	5.47	2009	6.04
7440	1787	4.20	1858	4.72	1926	5.25	1992	5.81	—	—
7875	1840	4.51	1909	5.03	1976	5.58	2040	6.14	—	—
8315	1894	4.81	1962	5.35	2027	5.90	—	—	—	—
8750	1950	5.12	2016	5.65	—	—	—	—	—	—

Std/Med Static 1048-2000 rpm, 4.8 maximum bhp (2.4 maximum bhp per fan motor)

High Static 1048-2200 rpm, 10.0 maximum bhp (5.0 maximum bhp per fan motor)

RAF210 — Standard/Medium Static — 17.5 Ton Vertical Supply (rpm - vdc)

CFM	AVAILABLE EXTERNAL STATIC PRESSURE (in. wg)									
	0.2		0.4		0.6		0.8		1.0	
	rpm	vdc	rpm	vdc	rpm	vdc	rpm	vdc	rpm	vdc
5250	1048	5.1	1162	5.7	1268	6.2	1366	6.7	1457	7.2
5690	1116	5.5	1220	6.0	1322	6.5	1417	7.0	1505	7.5
6125	1185	5.8	1281	6.3	1377	6.8	1469	7.3	1555	7.7
6565	1257	6.2	1344	6.6	1435	7.1	1523	7.5	1606	8.0
7000	1329	6.5	1409	7.0	1494	7.4	1578	7.8	1658	8.2
7440	1401	6.9	1475	7.3	1555	7.7	1635	8.1	1712	8.5
7875	1475	7.3	1543	7.6	1617	8.0	1693	8.4	1768	8.8
8315	1549	7.7	1612	8.0	1681	8.4	1753	8.7	1825	9.1
8750	1623	8.1	1682	8.4	1747	8.7	1815	9.0	1883	9.4

CFM	AVAILABLE EXTERNAL STATIC PRESSURE (in. wg)									
	1.2		1.4		1.6		1.8		2.0	
	rpm	vdc	rpm	vdc	rpm	vdc	rpm	vdc	rpm	vdc
5250	1543	7.6	1623	8.1	1700	8.5	1773	8.8	1844	9.2
5690	1588	7.9	1666	8.3	1741	8.7	1813	9.0	—	—
6125	1635	8.1	1712	8.5	1785	8.9	1855	9.3	—	—
6565	1684	8.4	1759	8.8	1830	9.1	—	—	—	—
7000	1735	8.6	1808	9.0	—	—	—	—	—	—
7440	1787	8.9	1858	9.3	—	—	—	—	—	—
7875	1840	9.2	—	—	—	—	—	—	—	—
8315	—	—	—	—	—	—	—	—	—	—
8750	—	—	—	—	—	—	—	—	—	—

Std/Med Static 1048-2000 rpm

Fan data (cont)

RAF210 — High Static — 17.5 Ton Vertical Supply (rpm - vdc)

CFM	AVAILABLE EXTERNAL STATIC PRESSURE (in. wg)									
	0.2		0.4		0.6		0.8		1.0	
	rpm	vdc	rpm	vdc	rpm	vdc	rpm	vdc	rpm	vdc
5250	1048	4.7	1162	5.2	1268	5.7	1366	6.2	1457	6.6
5690	1116	5.0	1220	5.5	1322	5.9	1417	6.4	1505	6.8
6125	1185	5.3	1281	5.8	1377	6.2	1469	6.6	1555	7.0
6565	1257	5.6	1344	6.0	1435	6.5	1523	6.9	1606	7.3
7000	1329	6.0	1409	6.3	1494	6.7	1578	7.1	1658	7.5
7440	1401	6.3	1475	6.7	1555	7.0	1635	7.4	1712	7.7
7875	1475	6.7	1543	7.0	1617	7.3	1693	7.7	1768	8.0
8315	1549	7.0	1612	7.3	1681	7.6	1753	7.9	1825	8.3
8750	1623	7.3	1682	7.6	1747	7.9	1815	8.2	1883	8.5

CFM	AVAILABLE EXTERNAL STATIC PRESSURE (in. wg)									
	1.2		1.4		1.6		1.8		2.0	
	rpm	vdc	rpm	vdc	rpm	vdc	rpm	vdc	rpm	vdc
5250	1543	7.0	1623	7.3	1700	7.7	1773	8.0	1844	8.4
5690	1588	7.2	1666	7.5	1741	7.9	1813	8.2	1882	8.5
6125	1635	7.4	1712	7.7	1785	8.1	1855	8.4	1922	8.7
6565	1684	7.6	1759	8.0	1830	8.3	1899	8.6	1965	8.9
7000	1735	7.9	1808	8.2	1877	8.5	1944	8.8	2009	9.1
7440	1787	8.1	1858	8.4	1926	8.7	1992	9.0	—	—
7875	1840	8.3	1909	8.7	1976	9.0	2040	9.3	—	—
8315	1894	8.6	1962	8.9	2027	9.2	—	—	—	—
8750	1950	8.8	2016	9.2	—	—	—	—	—	—

High Static 1048-2200 rpm

Fan data (cont)

RAF240 — 20 Ton Vertical Supply (rpm - bhp)

CFM	AVAILABLE EXTERNAL STATIC PRESSURE (in. wg)									
	0.2		0.4		0.6		0.8		1.0	
	rpm	bhp	rpm	bhp	rpm	bhp	rpm	bhp	rpm	bhp
6,000	1166	1.19	1263	1.52	1361	1.90	1454	2.31	1540	2.75
6,500	1246	1.45	1335	1.79	1427	2.18	1515	2.61	1598	3.06
7,000	1329	1.75	1409	2.08	1493	2.48	1578	2.92	1658	3.39
7,500	1412	2.07	1485	2.40	1563	2.80	1643	3.26	1720	3.73
8,000	1496	2.41	1563	2.75	1635	3.14	1710	3.60	1784	4.08
8,500	1581	2.77	1642	3.10	1709	3.50	1779	3.94	1850	4.44
9,000	1666	3.14	1723	3.47	1785	3.86	1850	4.30	1917	4.78
9,500	1752	3.52	1805	3.85	1862	4.22	1923	4.65	1986	5.12
10,000	1838	3.90	1887	4.22	1941	4.59	1998	5.01	2057	5.47

CFM	AVAILABLE EXTERNAL STATIC PRESSURE (in. wg)									
	1.2		1.4		1.6		1.8		2.0	
	rpm	bhp	rpm	bhp	rpm	bhp	rpm	bhp	rpm	bhp
6,000	1621	3.21	1698	3.68	1772	4.19	1842	4.70	1911	5.25
6,500	1677	3.54	1752	4.04	1823	4.55	1892	5.08	1958	5.63
7,000	1735	3.89	1808	4.40	1877	4.92	1944	5.47	2009	6.04
7,500	1794	4.24	1865	4.76	1933	5.30	1998	5.85	2061	6.43
8,000	1855	4.59	1924	5.12	1991	5.68	2054	6.23	2116	6.81
8,500	1918	4.94	1985	5.48	2050	6.04	2112	6.60	2172	7.18
9,000	1983	5.29	2047	5.82	2110	6.37	2171	6.94	—	—
9,500	2049	5.63	2111	6.15	2172	6.70	—	—	—	—
10,000	2117	5.96	2177	6.48	—	—	—	—	—	—

Std/Med Static 1166-2000 rpm, 4.8 maximum bhp (2.4 maximum bhp per fan motor)

High Static 1166-2200 rpm, 10.0 maximum bhp (5.0 maximum bhp per fan motor)

RAF240 — Standard/Medium Static — 20 Ton Vertical Supply (rpm - vdc)

CFM	AVAILABLE EXTERNAL STATIC PRESSURE (in. wg)									
	0.2		0.4		0.6		0.8		1.0	
	rpm	vdc	rpm	vdc	rpm	vdc	rpm	vdc	rpm	vdc
6,000	1166	5.2	1263	5.7	1361	6.1	1454	6.6	1540	7.0
6,500	1246	5.6	1335	6.0	1427	6.4	1515	6.8	1598	7.2
7,000	1329	6.0	1409	6.3	1493	6.7	1578	7.1	1658	7.5
7,500	1412	6.4	1485	6.7	1563	7.1	1643	7.4	1720	7.8
8,000	1496	6.8	1563	7.1	1635	7.4	1710	7.7	1784	8.1
8,500	1581	7.1	1642	7.4	1709	7.7	1779	8.1	1850	8.4
9,000	1666	7.5	1723	7.8	1785	8.1	1850	8.4	1917	8.7
9,500	1752	7.9	1805	8.2	1862	8.4	1923	8.7	—	—
10,000	1838	8.3	1887	8.6	1941	8.8	—	—	—	—

CFM	AVAILABLE EXTERNAL STATIC PRESSURE (in. wg)									
	1.2		1.4		1.6		1.8		2.0	
	rpm	vdc	rpm	vdc	rpm	vdc	rpm	vdc	rpm	vdc
6,000	1621	7.3	1698	7.7	1772	8.0	1842	8.3	—	—
6,500	1677	7.6	1752	7.9	1823	8.3	—	—	—	—
7,000	1735	7.9	1808	8.2	—	—	—	—	—	—
7,500	1794	8.1	1865	8.5	—	—	—	—	—	—
8,000	1855	8.4	—	—	—	—	—	—	—	—
8,500	—	—	—	—	—	—	—	—	—	—
9,000	—	—	—	—	—	—	—	—	—	—
9,500	—	—	—	—	—	—	—	—	—	—
10,000	—	—	—	—	—	—	—	—	—	—

Std/Med Static 1166-2000 rpm

Fan data (cont)

RAF240 — High Static — 20 Ton Vertical Supply (rpm - vdc)

CFM	AVAILABLE EXTERNAL STATIC PRESSURE (in. wg)									
	0.2		0.4		0.6		0.8		1.0	
	rpm	vdc	rpm	vdc	rpm	vdc	rpm	vdc	rpm	vdc
6,000	1166	5.2	1263	5.7	1361	6.1	1454	6.6	1540	7.0
6,500	1246	5.6	1335	6.0	1427	6.4	1515	6.8	1598	7.2
7,000	1329	6.0	1409	6.3	1493	6.7	1578	7.1	1658	7.5
7,500	1412	6.4	1485	6.7	1563	7.1	1643	7.4	1720	7.8
8,000	1496	6.8	1563	7.1	1635	7.4	1710	7.7	1784	8.1
8,500	1581	7.1	1642	7.4	1709	7.7	1779	8.1	1850	8.4
9,000	1666	7.5	1723	7.8	1785	8.1	1850	8.4	1917	8.7
9,500	1752	7.9	1805	8.2	1862	8.4	1923	8.7	1986	9.0
10,000	1838	8.3	1887	8.6	1941	8.8	1998	9.1	2057	9.3

CFM	AVAILABLE EXTERNAL STATIC PRESSURE (in. wg)									
	1.2		1.4		1.6		1.8		2.0	
	rpm	vdc	rpm	vdc	rpm	vdc	rpm	vdc	rpm	vdc
6,000	1621	7.3	1698	7.7	1772	8.0	1842	8.3	1911	8.7
6,500	1677	7.6	1752	7.9	1823	8.3	1892	8.6	1958	8.9
7,000	1735	7.9	1808	8.2	1877	8.5	1944	8.8	2009	9.1
7,500	1794	8.1	1865	8.5	1933	8.8	1998	9.1	2061	9.4
8,000	1855	8.4	1924	8.7	1991	9.0	2054	9.3	2116	9.6
8,500	1918	8.7	1985	9.0	2050	9.3	2112	9.6	2172	9.9
9,000	1983	9.0	2047	9.3	2110	9.6	2171	9.9	—	—
9,500	2049	9.3	2111	9.6	2172	9.9	—	—	—	—
10,000	2117	9.6	2177	9.9	—	—	—	—	—	—

High Static 1166-2200 rpm

Fan data (cont)

RAF300 — 25 Ton Vertical Supply (rpm - bhp)

CFM	AVAILABLE EXTERNAL STATIC PRESSURE (in. wg)									
	0.2		0.4		0.6		0.8		1.0	
	rpm	bhp	rpm	bhp	rpm	bhp	rpm	bhp	rpm	bhp
7,500	1105	1.30	1181	1.58	1263	1.93	1351	2.37	1441	2.87
8,125	1183	1.60	1252	1.90	1326	2.25	1405	2.68	1487	3.18
8,750	1263	1.96	1326	2.26	1393	2.62	1464	3.05	1538	3.53
9,375	1343	2.35	1401	2.67	1462	3.03	1527	3.45	1595	3.94
10,000	1424	2.78	1478	3.10	1534	3.47	1593	3.89	1655	4.36
10,625	1506	3.23	1556	3.56	1608	3.93	1663	4.35	1719	4.81
11,250	1587	3.70	1635	4.05	1683	4.42	1734	4.83	1786	5.28
11,875	1669	4.23	1714	4.58	1760	4.96	1807	5.37	1856	5.81
12,500	1752	4.86	1794	5.22	1837	5.60	1881	6.01	1927	6.47

CFM	AVAILABLE EXTERNAL STATIC PRESSURE (in. wg)									
	1.2		1.4		1.6		1.8		2.0	
	rpm	bhp	rpm	bhp	rpm	bhp	rpm	bhp	rpm	bhp
7,500	1528	3.42	1611	4.01	1690	4.63	1764	5.27	1834	5.92
8,125	1570	3.74	1650	4.34	1728	4.99	1801	5.65	1871	6.33
8,750	1615	4.09	1692	4.70	1767	5.36	1839	6.04	1909	6.76
9,375	1665	4.48	1736	5.07	1808	5.73	1878	6.42	1947	7.16
10,000	1720	4.89	1786	5.48	1853	6.12	1920	6.81	1986	7.53
10,625	1778	5.32	1840	5.89	1902	6.51	1965	7.18	2028	7.89
11,250	1841	5.78	1897	6.33	1955	6.93	2014	7.57	2074	8.27
11,875	1906	6.30	1958	6.83	2012	7.41	2067	8.03	2123	8.70
12,500	1974	6.95	2023	7.48	2073	8.05	2124	8.66	2176	9.31

Std/Med Static 1105-2200 rpm, 6.0 maximum bhp (3.0 maximum bhp per fan motor)

High Static 1105-2200 rpm, 10.0 maximum bhp (5.0 maximum bhp per fan motor)

RAF300 — Standard/Medium Static — 25 Ton Vertical Supply (rpm - vdc)

CFM	AVAILABLE EXTERNAL STATIC PRESSURE (in. wg)									
	0.2		0.4		0.6		0.8		1.0	
	rpm	vdc	rpm	vdc	rpm	vdc	rpm	vdc	rpm	vdc
7,500	1105	4.9	1181	5.3	1263	5.7	1351	6.1	1441	6.5
8,125	1183	5.3	1252	5.6	1326	6.0	1405	6.3	1487	6.7
8,750	1263	5.7	1326	6.0	1393	6.3	1464	6.6	1538	6.9
9,375	1343	6.0	1401	6.3	1462	6.6	1527	6.9	1595	7.2
10,000	1424	6.4	1478	6.7	1534	6.9	1593	7.2	1655	7.5
10,625	1506	6.8	1556	7.0	1608	7.3	1663	7.5	1719	7.8
11,250	1587	7.2	1635	7.4	1683	7.6	1734	7.8	1786	8.1
11,875	1669	7.5	1714	7.8	1760	8.0	1807	8.2	1856	8.4
12,500	1752	7.9	1794	8.1	1837	8.3	—	—	—	—

CFM	AVAILABLE EXTERNAL STATIC PRESSURE (in. wg)									
	1.2		1.4		1.6		1.8		2.0	
	rpm	vdc	rpm	vdc	rpm	vdc	rpm	vdc	rpm	vdc
7,500	1528	6.9	1611	7.3	1690	7.6	1764	8.0	1834	8.3
8,125	1570	7.1	1650	7.5	1728	7.8	1801	8.2	—	—
8,750	1615	7.3	1692	7.7	1767	8.0	—	—	—	—
9,375	1665	7.5	1736	7.9	1808	8.2	—	—	—	—
10,000	1720	7.8	1786	8.1	—	—	—	—	—	—
10,625	1778	8.1	1840	8.3	—	—	—	—	—	—
11,250	1841	8.3	—	—	—	—	—	—	—	—
11,875	—	—	—	—	—	—	—	—	—	—
12,500	—	—	—	—	—	—	—	—	—	—

Std/Med Static 1105-2000 rpm

Fan data (cont)

RAF300 — High Static — 25 Ton Vertical Supply (rpm - vdc)

CFM	AVAILABLE EXTERNAL STATIC PRESSURE (in. wg)									
	0.2		0.4		0.6		0.8		1.0	
	rpm	vdc	rpm	vdc	rpm	vdc	rpm	vdc	rpm	vdc
7,500	1105	4.9	1181	5.3	1263	5.7	1351	6.1	1441	6.5
8,125	1183	5.3	1252	5.6	1326	6.0	1405	6.3	1487	6.7
8,750	1263	5.7	1326	6.0	1393	6.3	1464	6.6	1538	6.9
9,375	1343	6.0	1401	6.3	1462	6.6	1527	6.9	1595	7.2
10,000	1424	6.4	1478	6.7	1534	6.9	1593	7.2	1655	7.5
10,625	1506	6.8	1556	7.0	1608	7.3	1663	7.5	1719	7.8
11,250	1587	7.2	1635	7.4	1683	7.6	1734	7.8	1786	8.1
11,875	1669	7.5	1714	7.8	1760	8.0	1807	8.2	1856	8.4
12,500	1752	7.9	1794	8.1	1837	8.3	1881	8.5	1927	8.7

CFM	AVAILABLE EXTERNAL STATIC PRESSURE (in. wg)									
	1.2		1.4		1.6		1.8		2.0	
	rpm	vdc	rpm	vdc	rpm	vdc	rpm	vdc	rpm	vdc
7,500	1528	6.9	1611	7.3	1690	7.6	1764	8.0	1834	8.3
8,125	1570	7.1	1650	7.5	1728	7.8	1801	8.2	1871	8.5
8,750	1615	7.3	1692	7.7	1767	8.0	1839	8.3	1909	8.7
9,375	1665	7.5	1736	7.9	1808	8.2	1878	8.5	1947	8.8
10,000	1720	7.8	1786	8.1	1853	8.4	1920	8.7	1986	9.0
10,625	1778	8.1	1840	8.3	1902	8.6	1965	8.9	2028	9.2
11,250	1841	8.3	1897	8.6	1955	8.9	2014	9.1	2074	9.4
11,875	1906	8.6	1958	8.9	2012	9.1	2067	9.4	2123	9.6
12,500	1974	9.0	2023	9.2	2073	9.4	2124	9.6	2176	9.9

High Static 1105-2200 rpm

Fan data (cont)

RAF336 — 27.5 Ton Vertical Supply (rpm - bhp)

CFM	AVAILABLE EXTERNAL STATIC PRESSURE (in. wg)									
	0.2		0.4		0.6		0.8		1.0	
	rpm	bhp	rpm	bhp	rpm	bhp	rpm	bhp	rpm	bhp
8,250	1193	1.64	1260	1.94	1332	2.29	1408	2.70	1488	3.19
8,940	1281	2.04	1341	2.34	1406	2.70	1474	3.11	1546	3.59
9,625	1369	2.48	1425	2.80	1483	3.16	1545	3.57	1609	4.03
10,300	1457	2.95	1509	3.28	1563	3.65	1619	4.05	1678	4.51
11,000	1547	3.46	1595	3.79	1645	4.16	1696	4.56	1750	5.01
11,690	1636	4.00	1682	4.35	1728	4.72	1776	5.12	1825	5.56
12,375	1726	4.64	1769	5.00	1812	5.37	1857	5.78	1903	6.22
13,060	1817	5.52	1857	5.89	1898	6.29	1939	6.71	1982	7.16
13,750	1907	6.85	1945	7.27	1984	7.72	2023	8.18	2063	8.68

CFM	AVAILABLE EXTERNAL STATIC PRESSURE (in. wg)									
	1.2		1.4		1.6		1.8		2.0	
	rpm	bhp	rpm	bhp	rpm	bhp	rpm	bhp	rpm	bhp
8,250	1570	3.75	1650	4.35	1727	4.99	1801	5.65	1871	6.34
8,940	1620	4.13	1695	4.73	1770	5.39	1842	6.07	1911	6.78
9,625	1677	4.56	1746	5.15	1816	5.79	1885	6.48	1953	7.21
10,300	1739	5.02	1802	5.59	1866	6.20	1932	6.88	1996	7.59
11,000	1806	5.51	1863	6.04	1923	6.65	1983	7.29	2044	7.98
11,690	1876	6.03	1929	6.56	1984	7.14	2040	7.76	2096	8.42
12,375	1950	6.70	1999	7.22	2049	7.77	2101	8.38	2153	9.01
13,060	2026	7.65	2071	8.17	2118	8.74	2166	9.35	—	—
13,750	2104	9.20	2147	9.78	—	—	—	—	—	—

Std/Med Static 1193-2200 rpm, 6.0 maximum bhp (3.0 maximum bhp per fan motor)

High Static 1193-2200 rpm, 10.0 maximum bhp (5.0 maximum bhp per fan motor)

RAF336 — Standard/Medium Static — 27.5 Ton Vertical Supply (rpm - vdc)

CFM	AVAILABLE EXTERNAL STATIC PRESSURE (in. wg)									
	0.2		0.4		0.6		0.8		1.0	
	rpm	vdc	rpm	vdc	rpm	vdc	rpm	vdc	rpm	vdc
8,250	1193	5.4	1260	5.7	1332	6.0	1408	6.3	1488	6.7
8,940	1281	5.8	1341	6.0	1406	6.3	1474	6.6	1546	7.0
9,625	1369	6.2	1425	6.4	1483	6.7	1545	7.0	1609	7.3
10,300	1457	6.6	1509	6.8	1563	7.1	1619	7.3	1678	7.6
11,000	1547	7.0	1595	7.2	1645	7.4	1696	7.7	1750	7.9
11,690	1636	7.4	1682	7.6	1728	7.8	1776	8.0	1825	8.3
12,375	1726	7.8	1769	8.0	1812	8.2	1857	8.4	—	—
13,060	1817	8.2	1857	8.4	—	—	—	—	—	—
13,750	—	—	—	—	—	—	—	—	—	—

CFM	AVAILABLE EXTERNAL STATIC PRESSURE (in. wg)									
	1.2		1.4		1.6		1.8		2.0	
	rpm	vdc	rpm	vdc	rpm	vdc	rpm	vdc	rpm	vdc
8,250	1570	7.1	1650	7.5	1727	7.8	1801	8.2	—	—
8,940	1620	7.3	1695	7.7	1770	8.0	—	—	—	—
9,625	1677	7.6	1746	7.9	1816	8.2	—	—	—	—
10,300	1739	7.9	1802	8.2	—	—	—	—	—	—
11,000	1806	8.2	—	—	—	—	—	—	—	—
11,690	—	—	—	—	—	—	—	—	—	—
12,375	—	—	—	—	—	—	—	—	—	—
13,060	—	—	—	—	—	—	—	—	—	—
13,750	—	—	—	—	—	—	—	—	—	—

Std/Med Static 1193-2200 rpm

Fan data (cont)

RAF336 — High Static — 27.5 Ton Vertical Supply (rpm - vdc)

CFM	AVAILABLE EXTERNAL STATIC PRESSURE (in. wg)									
	0.2		0.4		0.6		0.8		1.0	
	rpm	vdc	rpm	vdc	rpm	vdc	rpm	vdc	rpm	vdc
8,250	1193	5.4	1260	5.7	1332	6.0	1408	6.3	1488	6.7
8,940	1281	5.8	1341	6.0	1406	6.3	1474	6.6	1546	7.0
9,625	1369	6.2	1425	6.4	1483	6.7	1545	7.0	1609	7.3
10,300	1457	6.6	1509	6.8	1563	7.1	1619	7.3	1678	7.6
11,000	1547	7.0	1595	7.2	1645	7.4	1696	7.7	1750	7.9
11,690	1636	7.4	1682	7.6	1728	7.8	1776	8.0	1825	8.3
12,375	1726	7.8	1769	8.0	1812	8.2	1857	8.4	1903	8.6
13,060	1817	8.2	1857	8.4	1898	8.6	1939	8.8	1982	9.0
13,750	1907	8.6	1945	8.8	1984	9.0	2023	9.2	2063	9.4

CFM	AVAILABLE EXTERNAL STATIC PRESSURE (in. wg)									
	1.2		1.4		1.6		1.8		2.0	
	rpm	vdc	rpm	vdc	rpm	vdc	rpm	vdc	rpm	vdc
8,250	1570	7.1	1650	7.5	1727	7.8	1801	8.2	1871	8.5
8,940	1620	7.3	1695	7.7	1770	8.0	1842	8.3	1911	8.7
9,625	1677	7.6	1746	7.9	1816	8.2	1885	8.5	1953	8.9
10,300	1739	7.9	1802	8.2	1866	8.5	1932	8.8	1996	9.1
11,000	1806	8.2	1863	8.4	1923	8.7	1983	9.0	2044	9.3
11,690	1876	8.5	1929	8.7	1984	9.0	2040	9.3	2096	9.5
12,375	1950	8.8	1999	9.1	2049	9.3	2101	9.5	2153	9.8
13,060	2026	9.2	2071	9.4	2118	9.6	2166	9.8	—	—
13,750	2104	9.6	2147	9.8	—	—	—	—	—	—

High Static 1193-2200 rpm

Fan data (cont)

RAF210 — 17.5 Ton Horizontal Supply (rpm - bhp)

CFM	AVAILABLE EXTERNAL STATIC PRESSURE (in. wg)									
	0.2		0.4		0.6		0.8		1.0	
	rpm	bhp	rpm	bhp	rpm	bhp	rpm	bhp	rpm	bhp
5250	1190	1.01	1293	1.30	1390	1.61	1482	1.95	1569	2.32
5690	1271	1.22	1366	1.52	1458	1.85	1546	2.20	1629	2.58
6125	1352	1.46	1442	1.77	1528	2.10	1612	2.47	1692	2.86
6560	1434	1.71	1519	2.04	1601	2.39	1680	2.76	1756	3.15
7000	1517	2.00	1597	2.33	1675	2.69	1750	3.06	1823	3.46
7440	1600	2.30	1677	2.65	1750	3.01	1822	3.39	1892	3.80
7875	1684	2.63	1757	2.98	1827	3.36	1895	3.74	1962	4.16
8310	1768	2.98	1838	3.35	1905	3.73	1970	4.12	2034	4.54
8750	1853	3.36	1920	3.73	1984	4.12	2046	4.52	2108	4.94

CFM	AVAILABLE EXTERNAL STATIC PRESSURE (in. wg)									
	1.2		1.4		1.6		1.8		2.0	
	rpm	bhp	rpm	bhp	rpm	bhp	rpm	bhp	rpm	bhp
5250	1652	2.70	1730	3.10	1805	3.53	1876	3.96	1946	4.42
5690	1709	2.97	1785	3.39	1858	3.82	1928	4.27	1995	4.73
6125	1769	3.26	1842	3.69	1913	4.13	1981	4.58	2047	5.06
6560	1830	3.56	1901	3.99	1970	4.45	2037	4.92	2101	5.39
7000	1894	3.88	1963	4.33	2029	4.78	2094	5.25	2157	5.74
7440	1960	4.23	2026	4.67	2091	5.13	2153	5.60	—	—
7875	2027	4.58	2091	5.03	2154	5.50	—	—	—	—
8310	2097	4.97	2158	5.42	—	—	—	—	—	—
8750	2168	5.38	—	—	—	—	—	—	—	—

High Static 1190-2200 rpm, 10.0 maximum bhp (5.0 maximum bhp per fan motor)

RAF210 — High Static — 17.5 Ton Horizontal Supply (rpm - vdc)

CFM	AVAILABLE EXTERNAL STATIC PRESSURE (in. wg)									
	0.2		0.4		0.6		0.8		1.0	
	rpm	vdc	rpm	vdc	rpm	vdc	rpm	vdc	rpm	vdc
5250	1190	5.3	1293	5.8	1390	6.3	1482	6.7	1569	7.1
5690	1271	5.7	1366	6.2	1458	6.6	1546	7.0	1629	7.4
6125	1352	6.1	1442	6.5	1528	6.9	1612	7.3	1692	7.7
6560	1434	6.5	1519	6.9	1601	7.2	1680	7.6	1756	8.0
7000	1517	6.8	1597	7.2	1675	7.6	1750	7.9	1823	8.3
7440	1600	7.2	1677	7.6	1750	7.9	1822	8.3	1892	8.6
7875	1684	7.6	1757	8.0	1827	8.3	1895	8.6	1962	8.9
8310	1768	8.0	1838	8.3	1905	8.6	1970	8.9	2034	9.2
8750	1853	8.4	1920	8.7	1984	9.0	2046	9.3	2108	9.6

CFM	AVAILABLE EXTERNAL STATIC PRESSURE (in. wg)									
	1.2		1.4		1.6		1.8		2.0	
	rpm	vdc	rpm	vdc	rpm	vdc	rpm	vdc	rpm	vdc
5250	1652	7.5	1730	7.8	1805	8.2	1876	8.5	1946	8.8
5690	1709	7.7	1785	8.1	1858	8.4	1928	8.7	1995	9.1
6125	1769	8.0	1842	8.3	1913	8.7	1981	9.0	2047	9.3
6560	1830	8.3	1901	8.6	1970	8.9	2037	9.2	2101	9.5
7000	1894	8.6	1963	8.9	2029	9.2	2094	9.5	2157	9.8
7440	1960	8.9	2026	9.2	2091	9.5	2153	9.8	—	—
7875	2027	9.2	2091	9.5	2154	9.8	—	—	—	—
8310	2097	9.5	2158	9.8	—	—	—	—	—	—
8750	2168	9.9	—	—	—	—	—	—	—	—

High Static 1190-2200 rpm

Fan data (cont)

RAF240 — 20 Ton Horizontal Supply (rpm - bhp)

CFM	AVAILABLE EXTERNAL STATIC PRESSURE (in. wg)									
	0.2		0.4		0.6		0.8		1.0	
	rpm	bhp	rpm	bhp	rpm	bhp	rpm	bhp	rpm	bhp
6,000	1328	1.39	1420	1.69	1508	2.03	1592	2.39	1674	2.78
6,500	1422	1.68	1508	2.00	1590	2.34	1670	2.71	1747	3.11
7,000	1517	2.00	1597	2.33	1675	2.69	1750	3.06	1823	3.46
7,500	1612	2.34	1688	2.69	1761	3.06	1832	3.44	1902	3.85
8,000	1708	2.73	1780	3.09	1849	3.46	1917	3.85	1983	4.27
8,500	1804	3.14	1873	3.51	1939	3.89	2003	4.29	2065	4.70
9,000	1901	3.58	1966	3.95	2029	4.35	2090	4.75	2150	5.17
9,500	1998	4.01	2061	4.40	2121	4.80	2179	5.21	—	—
10,000	2096	4.40	2155	4.78	—	—	—	—	—	—

CFM	AVAILABLE EXTERNAL STATIC PRESSURE (in. wg)									
	1.2		1.4		1.6		1.8		2.0	
	rpm	bhp	rpm	bhp	rpm	bhp	rpm	bhp	rpm	bhp
6,000	1751	3.18	1826	3.60	1897	4.04	1966	4.50	2032	4.96
6,500	1821	3.52	1893	3.95	1962	4.40	2029	4.87	2093	5.34
7,000	1894	3.88	1963	4.33	2029	4.78	2094	5.25	2157	5.74
7,500	1969	4.27	2035	4.72	2099	5.18	2162	5.66	—	—
8,000	2047	4.69	2110	5.14	2172	5.61	—	—	—	—
8,500	2127	5.14	2187	5.59	—	—	—	—	—	—
9,000	—	—	—	—	—	—	—	—	—	—
9,500	—	—	—	—	—	—	—	—	—	—
10,000	—	—	—	—	—	—	—	—	—	—

High Static 1328-2200 rpm, 10.0 maximum bhp (5.0 maximum bhp per fan motor)

RAF240 — High Static — 20 Ton Horizontal Supply (rpm - vdc)

CFM	AVAILABLE EXTERNAL STATIC PRESSURE (in. wg)									
	0.2		0.4		0.6		0.8		1.0	
	rpm	vdc	rpm	vdc	rpm	vdc	rpm	vdc	rpm	vdc
6,000	1328	6.0	1420	6.4	1508	6.8	1592	7.2	1674	7.6
6,500	1422	6.4	1508	6.8	1590	7.2	1670	7.6	1747	7.9
7,000	1517	6.8	1597	7.2	1675	7.6	1750	7.9	1823	8.3
7,500	1612	7.3	1688	7.6	1761	8.0	1832	8.3	1902	8.6
8,000	1708	7.7	1780	8.1	1849	8.4	1917	8.7	1983	9.0
8,500	1804	8.2	1873	8.5	1939	8.8	2003	9.1	2065	9.4
9,000	1901	8.6	1966	8.9	2029	9.2	2090	9.5	2150	9.8
9,500	1998	9.1	2061	9.4	2121	9.6	2179	9.9	—	—
10,000	2096	9.5	2155	9.8	—	—	—	—	—	—

CFM	AVAILABLE EXTERNAL STATIC PRESSURE (in. wg)									
	1.2		1.4		1.6		1.8		2.0	
	rpm	vdc	rpm	vdc	rpm	vdc	rpm	vdc	rpm	vdc
6,000	1751	7.9	1826	8.3	1897	8.6	1966	8.9	2032	9.2
6,500	1821	8.3	1893	8.6	1962	8.9	2029	9.2	2093	9.5
7,000	1894	8.6	1963	8.9	2029	9.2	2094	9.5	2157	9.8
7,500	1969	8.9	2035	9.2	2099	9.5	2162	9.8	—	—
8,000	2047	9.3	2110	9.6	2172	9.9	—	—	—	—
8,500	2127	9.7	2187	9.9	—	—	—	—	—	—
9,000	—	—	—	—	—	—	—	—	—	—
9,500	—	—	—	—	—	—	—	—	—	—
10,000	—	—	—	—	—	—	—	—	—	—

High Static 1328-2200 rpm

Fan data (cont)

RAF300 — 25 Ton Horizontal Supply (rpm - bhp)

CFM	AVAILABLE EXTERNAL STATIC PRESSURE (in. wg)									
	0.2		0.4		0.6		0.8		1.0	
	rpm	bhp	rpm	bhp	rpm	bhp	rpm	bhp	rpm	bhp
7,500	1415	2.15	1491	2.51	1568	2.92	1645	3.37	1719	3.85
8,125	1519	2.65	1589	3.03	1660	3.46	1732	3.93	1801	4.42
8,750	1623	3.21	1689	3.62	1755	4.06	1821	4.54	1886	5.04
9,375	1729	3.84	1790	4.26	1851	4.71	1912	5.20	1974	5.72
10,000	1835	4.53	1892	4.96	1949	5.42	2007	5.92	2065	6.45
10,625	1942	5.26	1995	5.70	2049	6.18	2103	6.68	2157	7.20
11,250	2049	6.02	2099	6.47	2149	6.95	2200	7.45	—	—
11,875	2156	6.79	—	—	—	—	—	—	—	—
12,500	—	—	—	—	—	—	—	—	—	—

CFM	AVAILABLE EXTERNAL STATIC PRESSURE (in. wg)									
	1.2		1.4		1.6		1.8		2.0	
	rpm	bhp	rpm	bhp	rpm	bhp	rpm	bhp	rpm	bhp
7,500	1792	4.36	1862	4.89	1929	5.44	1993	6.00	2055	6.58
8,125	1870	4.94	1937	5.49	2002	6.07	2064	6.65	2125	7.25
8,750	1951	5.58	2015	6.15	2077	6.73	2137	7.33	2196	7.95
9,375	2035	6.26	2096	6.84	2155	7.44	—	—	—	—
10,000	2123	7.01	2180	7.59	—	—	—	—	—	—
10,625	—	—	—	—	—	—	—	—	—	—
11,250	—	—	—	—	—	—	—	—	—	—
11,875	—	—	—	—	—	—	—	—	—	—
12,500	—	—	—	—	—	—	—	—	—	—

High Static 1415-2200 rpm, 10.0 maximum bhp (5.0 maximum bhp per fan motor)

RAF300 — High Static — 25 Ton Horizontal Supply (rpm - vdc)

CFM	AVAILABLE EXTERNAL STATIC PRESSURE (in. wg)									
	0.2		0.4		0.6		0.8		1.0	
	rpm	vdc	rpm	vdc	rpm	vdc	rpm	vdc	rpm	vdc
7,500	1415	6.4	1491	6.7	1568	7.1	1645	7.4	1719	7.8
8,125	1519	6.9	1589	7.2	1660	7.5	1732	7.8	1801	8.2
8,750	1623	7.3	1689	7.6	1755	7.9	1821	8.3	1886	8.6
9,375	1729	7.8	1790	8.1	1851	8.4	1912	8.7	1974	9.0
10,000	1835	8.3	1892	8.6	1949	8.8	2007	9.1	2065	9.4
10,625	1942	8.8	1995	9.1	2049	9.3	2103	9.6	2157	9.8
11,250	2049	9.3	2099	9.5	2149	9.8	2200	10.0	—	—
11,875	2156	9.8	—	—	—	—	—	—	—	—
12,500	—	—	—	—	—	—	—	—	—	—

CFM	AVAILABLE EXTERNAL STATIC PRESSURE (in. wg)									
	1.2		1.4		1.6		1.8		2.0	
	rpm	vdc	rpm	vdc	rpm	vdc	rpm	vdc	rpm	vdc
7,500	1792	8.1	1862	8.4	1929	8.7	1993	9.0	2055	9.3
8,125	1870	8.5	1937	8.8	2002	9.1	2064	9.4	2125	9.7
8,750	1951	8.9	2015	9.1	2077	9.4	2137	9.7	2196	10.0
9,375	2035	9.2	2096	9.5	2155	9.8	—	—	—	—
10,000	2123	9.6	2180	9.9	—	—	—	—	—	—
10,625	—	—	—	—	—	—	—	—	—	—
11,250	—	—	—	—	—	—	—	—	—	—
11,875	—	—	—	—	—	—	—	—	—	—
12,500	—	—	—	—	—	—	—	—	—	—

High Static 1415-2200 rpm

Fan data (cont)

RAF336 — 27.5 Ton Horizontal Supply (rpm - bhp)

CFM	AVAILABLE EXTERNAL STATIC PRESSURE (in. wg)									
	0.2		0.4		0.6		0.8		1.0	
	rpm	bhp	rpm	bhp	rpm	bhp	rpm	bhp	rpm	bhp
8250	1530	2.70	1599	3.09	1669	3.51	1739	3.97	1808	4.46
8940	1645	3.33	1709	3.74	1773	4.18	1837	4.64	1902	5.15
9625	1761	4.04	1819	4.45	1879	4.90	1939	5.39	1999	5.91
10300	1877	4.80	1932	5.23	1987	5.69	2043	6.19	2099	6.71
11000	1994	5.61	2045	6.05	2096	6.52	2149	7.02	—	—
11690	2111	6.44	2159	6.89	—	—	—	—	—	—
12375	—	—	—	—	—	—	—	—	—	—
13060	—	—	—	—	—	—	—	—	—	—
13750	—	—	—	—	—	—	—	—	—	—

CFM	AVAILABLE EXTERNAL STATIC PRESSURE (in. wg)									
	1.2		1.4		1.6		1.8		2.0	
	rpm	bhp	rpm	bhp	rpm	bhp	rpm	bhp	rpm	bhp
8250	1876	4.99	1943	5.54	2007	6.11	2070	6.70	2130	7.30
8940	1966	5.69	2028	6.25	2090	6.84	2150	7.44	—	—
9625	2059	6.45	2118	7.02	2176	7.62	—	—	—	—
10300	2155	7.26	—	—	—	—	—	—	—	—
11000	—	—	—	—	—	—	—	—	—	—
11690	—	—	—	—	—	—	—	—	—	—
12375	—	—	—	—	—	—	—	—	—	—
13060	—	—	—	—	—	—	—	—	—	—
13750	—	—	—	—	—	—	—	—	—	—

High Static 1530-2200 rpm, 10.0 maximum bhp (5.0 maximum bhp per fan motor)

RAF336 — High Static — 27.5 Ton Horizontal Supply (rpm - vdc)

CFM	AVAILABLE EXTERNAL STATIC PRESSURE (in. wg)									
	0.2		0.4		0.6		0.8		1.0	
	rpm	vdc	rpm	vdc	rpm	vdc	rpm	vdc	rpm	vdc
8250	1530	6.9	1599	7.2	1669	7.5	1739	7.9	1808	8.2
8940	1645	7.4	1709	7.7	1773	8.0	1837	8.3	1902	8.6
9625	1761	8.0	1819	8.2	1879	8.5	1939	8.8	1999	9.1
10300	1877	8.5	1932	8.8	1987	9.0	2043	9.3	2099	9.5
11000	1994	9.0	2045	9.3	2096	9.5	2149	9.8	—	—
11690	2111	9.6	2159	9.8	—	—	—	—	—	—
12375	—	—	—	—	—	—	—	—	—	—
13060	—	—	—	—	—	—	—	—	—	—
13750	—	—	—	—	—	—	—	—	—	—

CFM	AVAILABLE EXTERNAL STATIC PRESSURE (in. wg)									
	1.2		1.4		1.6		1.8		2.0	
	rpm	vdc	rpm	vdc	rpm	vdc	rpm	vdc	rpm	vdc
8250	1876	8.5	1943	8.8	2007	9.1	2070	9.4	2130	9.7
8940	1966	8.9	2028	9.2	2090	9.5	2150	9.8	—	—
9625	2059	9.3	2118	9.6	2176	9.9	—	—	—	—
10300	2155	9.8	—	—	—	—	—	—	—	—
11000	—	—	—	—	—	—	—	—	—	—
11690	—	—	—	—	—	—	—	—	—	—
12375	—	—	—	—	—	—	—	—	—	—
13060	—	—	—	—	—	—	—	—	—	—
13750	—	—	—	—	—	—	—	—	—	—

High Static 1530-2200 rpm

Electrical data

Legend and Notes

Applicable for Electrical Data Tables on pages 90 to 104

LEGEND

BRKR	—	Circuit Breaker
C.O.	—	Convenience Outlet
FLA	—	Full Load Amps
IFM	—	Indoor Fan Motor
LRA	—	Locked Rotor Amps
MCA	—	Minimum Circuit Amps
P.E.	—	Power Exhaust
PWRD C.O.	—	Powered Convenience Outlet
RLA	—	Rated Load Amps
SCCR	—	Short Circuit Current Rating
UNPWR C.O.	—	Unpowered Convenience Outlet

NOTES:

1. In compliance with NEC requirements for multi-motor and combination load equipment (refer to NEC Articles 430 and 440), the overcurrent protective device for the unit shall be fuse or HACR breaker. Canadian units may be fuse or circuit breaker.
2. For 208/230 v units, where one value is show it is the same for either 208 or 230 volts.
3. **Unbalanced 3-Phase Supply Voltage:** Never operate a motor where a phase imbalance in supply voltage is greater than 2%. Use the following formula to determine the percentage of voltage imbalance.

$$\% \text{ Voltage Imbalance} = 100 \times \frac{\text{max voltage deviation from average voltage}}{\text{average voltage}}$$

Example: Supply voltage is 230-3-60

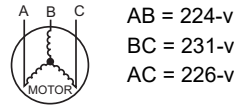

$$\text{Average Voltage} = \frac{(224 + 231 + 226)}{3} = \frac{681}{3} = 227$$

Determine maximum deviation from average voltage.

(AB) 227-224 = 3-v

(BC) 231-227 = 4-v

(AC) 227-226 = 1-v

Maximum deviation is 4-v.

Determine percent of voltage imbalance.

$$\% \text{ Voltage Imbalance} = 100 \times \frac{4}{227} = 1.78\%$$

This amount of phase imbalance is satisfactory as it is below the maximum allowable 2%.

IMPORTANT: If the supply voltage phase imbalance is more than 2%, contact your local electric utility company immediately.

Electrical data (cont)

RGF/RAF210-336 Cooling Electrical Data

RGF/RAF UNIT SIZE	V-Ph-Hz	UNIT VOLTAGE		STD SCCR kA	HIGH SCCR kA ^a	COMP 1		COMP 2		OFM (EA)		IFM			COMBUSTION FAN MOTOR (RGF SERIES ONLY)	POWER EXHAUST	
		Range				RLA	LRA	RLA	LRA	WATTS	FLA	Type	Effcy at Full Load	FLA	FLA	Motor Qty	FLA (Each motor)
		Min	Max														
210 Vertical	208-3-60	187	253	5	60	31.8	255	31.9	208	350	1.5	STD/MED HIGH	90.0% 90.0%	6.4 7.5	0.52	2	5.9
	230-3-60	187	253	5	60	31.8	255	31.9	208	350	1.5	STD/MED HIGH	90.0% 90.0%	6.4 7.5	0.52	2	5.9
	460-3-60	414	506	5	65	15.0	123	13.9	100	277	0.9	STD/MED HIGH	90.0% 90.0%	3.0 3.5	0.3	2	3.1
	575-3-60	518	633	5	—	11.9	94	10.0	78	397	0.6	STD/MED HIGH	90.0% 90.0%	2.5 3.0	0.24	2	2.4
240 Vertical	208-3-60	187	253	5	60	37.1	255	37.1	255	350	1.5	STD/MED HIGH	90.0% 90.0%	6.4 12.6	0.52	2	5.9
	230-3-60	187	253	5	60	37.1	255	37.1	255	350	1.5	STD/MED HIGH	90.0% 90.0%	6.4 12.6	0.52	2	5.9
	460-3-60	414	506	5	65	17.1	140	17.1	140	277	0.9	STD/MED HIGH	90.0% 90.0%	3.0 5.6	0.3	2	3.1
	575-3-60	518	633	5	—	14.4	108	14.4	108	397	0.6	STD/MED HIGH	90.0% 90.0%	2.5 4.6	0.24	2	2.4
300 Vertical	208-3-60	187	253	5	60	45.4	270	45.4	270	350	1.5	STD/MED HIGH	90.0% 90.0%	7.5 12.6	0.52	2	5.9
	230-3-60	187	253	5	60	45.4	270	45.4	270	350	1.5	STD/MED HIGH	90.0% 90.0%	7.5 12.6	0.52	2	5.9
	460-3-60	414	506	5	65	21.6	147	21.6	147	277	0.9	STD/MED HIGH	90.0% 90.0%	3.5 5.6	0.3	2	3.1
	575-3-60	518	633	5	—	15.3	109	15.3	109	397	0.6	STD/MED HIGH	90.0% 90.0%	3.0 4.6	0.24	2	2.4
336 Vertical	208-3-60	187	253	5	60	51.3	300	51.3	300	350	1.5	STD/MED HIGH	90.0% 90.0%	7.5 12.6	0.52	2	5.9
	230-3-60	187	253	5	60	51.3	300	51.3	300	350	1.5	STD/MED HIGH	90.0% 90.0%	7.5 12.6	0.52	2	5.9
	460-3-60	414	506	5	65	22.4	150	22.4	150	277	0.9	STD/MED HIGH	90.0% 90.0%	3.5 5.6	0.3	2	3.1
	575-3-60	518	633	5	—	19.9	109	19.9	109	397	0.6	STD/MED HIGH	90.0% 90.0%	3.0 4.6	0.24	2	2.4
210 Horizontal	208-3-60	187	253	5	60	31.8	255	31.9	208	350	1.5	HIGH	90.0%	12.6	0.52	2	5.9
	230-3-60	187	253	5	60	31.8	255	31.9	208	350	1.5	HIGH	90.0%	12.6	0.52	2	5.9
	460-3-60	414	506	5	65	15.0	123	13.9	100	277	0.9	HIGH	90.0%	5.6	0.3	2	3.1
	575-3-60	518	633	5	—	11.9	94	10.0	78	397	0.6	HIGH	90.0%	4.6	0.24	2	2.4
240 Horizontal	208-3-60	187	253	5	60	37.1	255	37.1	255	350	1.5	HIGH	90.0%	12.6	0.52	2	5.9
	230-3-60	187	253	5	60	37.1	255	37.1	255	350	1.5	HIGH	90.0%	12.6	0.52	2	5.9
	460-3-60	414	506	5	65	17.1	140	17.1	140	277	0.9	HIGH	90.0%	5.6	0.3	2	3.1
	575-3-60	518	633	5	—	14.4	108	14.4	108	397	0.6	HIGH	90.0%	4.6	0.24	2	2.4
300 Horizontal	208-3-60	187	253	5	60	45.4	270	45.4	270	350	1.5	HIGH	90.0%	12.6	0.52	2	5.9
	230-3-60	187	253	5	60	45.4	270	45.4	270	350	1.5	HIGH	90.0%	12.6	0.52	2	5.9
	460-3-60	414	506	5	65	21.6	147	21.6	147	277	0.9	HIGH	90.0%	5.6	0.3	2	3.1
	575-3-60	518	633	5	—	15.3	109	15.3	109	397	0.6	HIGH	90.0%	4.6	0.24	2	2.4
336 Horizontal	208-3-60	187	253	5	60	51.3	300	51.3	300	350	1.5	HIGH	90.0%	12.6	0.52	2	5.9
	230-3-60	187	253	5	60	51.3	300	51.3	300	350	1.5	HIGH	90.0%	12.6	0.52	2	5.9
	460-3-60	414	506	5	65	22.4	150	22.4	150	277	0.9	HIGH	90.0%	5.6	0.3	2	3.1
	575-3-60	518	633	5	—	19.9	109	19.9	109	397	0.6	HIGH	90.0%	4.6	0.24	2	2.4

NOTE(S):

a. High SCCR (Short Circuit Current Rating) is not available on the following: units with Hot Gas Re-Heat system, Low Ambient controls, Phase loss monitor, Non-fused disconnect, Powered convenience outlet, or 575V models.

Electrical data (cont)

RGF210-336 MCA MOCP Electrical Data

RGF UNIT SIZE	NOM. V-Ph-Hz	IFM TYPE	STD SCCR kA	HIGH SCCR kA ^a	NO CONVENIENCE OUTLET OR UNPOWERED CONVENIENCE OUTLET							
					No Power Exhaust				With Power Exhaust (powered from unit)			
					MCA	Fuse or HACR Breaker	Disconnect Size		MCA	Fuse or HACR Breaker	Disconnect Size	
							FLA	LRA			FLA	LRA
RGF210 Vertical	208/230-3-60	STD/MED	5	60	89	100	93	490	101	125	107	510
		HIGH			91	100	96	494	103	125	109	514
	460-3-60	STD/MED	5	65	41	50	43	237	48	60	50	249
		HIGH			42	50	44	239	49	60	52	251
	575-3-60	STD/MED	5	—	32	40	33	186	36	45	39	194
		HIGH			33	40	34	186	38	45	40	194
RGF240 Vertical	208/230-3-60	STD/MED	5	60	102	125	107	540	114	150	121	560
		HIGH			115	150	121	558	126	150	135	578
	460-3-60	STD/MED	5	65	48	60	50	296	54	60	58	308
		HIGH			53	60	56	304	60	70	63	316
	575-3-60	STD/MED	5	—	40	50	42	232	45	50	47	240
		HIGH			44	50	46	236	49	60	52	244
RGF300 Vertical	208/230-3-60	STD/MED	5	60	123	150	129	574	135	175	142	594
		HIGH			133	175	140	588	145	175	154	608
	460-3-60	STD/MED	5	65	59	80	62	312	65	80	69	324
		HIGH			63	80	67	318	70	90	74	330
	575-3-60	STD/MED	5	—	43	50	45	234	48	60	50	242
		HIGH			46	60	49	238	51	60	54	246
RGF336 Vertical	208/230-3-60	STD/MED	5	60	139	175	146	640	151	200	159	660
		HIGH			150	200	157	654	161	200	171	674
	460-3-60	STD/MED	5	65	63	80	66	322	69	90	73	334
		HIGH			67	80	71	328	73	90	78	340
	575-3-60	STD/MED	5	—	54	60	57	238	59	70	62	246
		HIGH			58	70	60	242	62	80	66	250
RGF210 Horizontal	208/230-3-60	HIGH	5	60	93	100	98	476	104	125	112	496
	460-3-60	HIGH	5	65	45	50	48	252	51	60	55	264
	575-3-60	HIGH	5	—	35	45	37	190	39	50	42	198
RGF240 Horizontal	208/230-3-60	HIGH	5	60	101	125	107	508	113	125	121	528
	460-3-60	HIGH	5	65	47	60	49	245	53	60	56	257
	575-3-60	HIGH	5	—	36	45	38	190	41	50	43	198
RGF300 Horizontal	208/230-3-60	HIGH	5	60	115	150	121	558	126	150	135	578
	460-3-60	HIGH	5	65	53	60	56	304	60	70	63	316
	575-3-60	HIGH	5	—	44	50	46	236	49	60	52	244
RGF336 Horizontal	208/230-3-60	HIGH	5	60	133	175	140	588	145	175	154	608
	460-3-60	HIGH	5	65	63	80	67	318	70	90	74	330
	575-3-60	HIGH	5	—	46	60	49	238	51	60	54	246

NOTE(S):

- a. High SCCR (Short Circuit Current Rating) is not available on the following: units with Hot Gas Re-Heat system, Low Ambient controls, Phase loss monitor, Non-fused disconnect, or 575V models.

Electrical data (cont)

RGF210-336 MCA MOCPP Electrical Data (cont)

RGF UNIT SIZE	NOM. V-Ph-Hz	IFM TYPE	STD SCCR kA	WITH POWERED CONVENIENCE OUTLET							
				No Power Exhaust				With Power Exhaust (powered from unit)			
				MCA	Fuse or HACR Breaker	Disconnect Size		MCA	Fuse or HACR Breaker	Disconnect Size	
						FLA	LRA			FLA	LRA
RGF210 Vertical	208/230-3-60	STD/MED	5	94	125	99	495	106	125	112	515
		HIGH		96	125	101	499	108	125	115	519
	460-3-60	STD/MED	5	44	50	46	239	50	60	53	251
		HIGH		45	50	47	241	51	60	54	253
	575-3-60	STD/MED	5	33	45	35	188	38	50	40	196
		HIGH		34	45	36	188	39	50	42	196
RGF240 Vertical	208/230-3-60	STD/MED	5	107	125	112	545	119	150	126	565
		HIGH		120	150	127	563	131	150	140	583
	460-3-60	STD/MED	5	50	60	53	298	56	70	60	310
		HIGH		56	60	59	306	62	70	66	318
	575-3-60	STD/MED	5	42	50	44	234	46	60	49	242
		HIGH		46	60	48	238	50	60	54	246
RGF300 Vertical	208/230-3-60	STD/MED	5	128	150	134	579	140	175	148	599
		HIGH		138	175	146	593	150	175	159	613
	460-3-60	STD/MED	5	61	80	64	314	68	80	72	326
		HIGH		66	80	69	320	72	90	76	332
	575-3-60	STD/MED	5	44	50	47	236	49	60	52	244
		HIGH		48	60	50	240	52	60	56	248
RGF336 Vertical	208/230-3-60	STD/MED	5	144	175	151	645	156	200	165	665
		HIGH		154	200	163	659	166	200	176	679
	460-3-60	STD/MED	5	65	80	68	324	71	90	75	336
		HIGH		69	90	73	330	75	90	80	342
	575-3-60	STD/MED	5	56	70	59	240	61	80	64	248
		HIGH		59	70	62	244	64	80	68	252
RGF210 Horizontal	208/230-3-60	HIGH	5	106	125	113	513	118	150	127	533
	460-3-60	HIGH	5	49	60	52	247	55	60	59	259
	575-3-60	HIGH	5	38	45	40	192	42	50	45	200
RGF240 Horizontal	208/230-3-60	HIGH	5	120	150	127	563	131	150	140	583
	460-3-60	HIGH	5	56	60	59	306	62	70	66	318
	575-3-60	HIGH	5	46	60	48	238	50	60	54	246
RGF300 Horizontal	208/230-3-60	HIGH	5	138	175	146	593	150	175	159	613
	460-3-60	HIGH	5	66	80	69	320	72	90	76	332
	575-3-60	HIGH	5	48	60	50	240	52	60	56	248
RGF336 Horizontal	208/230-3-60	HIGH	5	154	200	163	659	166	200	176	679
	460-3-60	HIGH	5	69	90	73	330	75	90	80	342
	575-3-60	HIGH	5	59	70	62	244	64	80	68	252

Electrical data (cont)

RAF210 MCA MOCP Electrical Data

RAF UNIT SIZE	NOM. V-Ph-Hz	IFM TYPE	STD SCCR kA	HIGH SCCR kA ^a	ELECTRIC HEATER				NO CONVENIENCE OUTLET or UNPOWERED CONVENIENCE OUTLET								
					STD SCCR CRHEATER ****00	HIGH SCCR CRHEATER ****00	NOM (kW)	FLA	No Power Exhaust				With Power Exhaust (powered from unit)				
									MCA	Fuse or HACR Breaker	Disconnect Size		MCA	Fuse or HACR Breaker	Disconnect Size		
											FLA	LRA			FLA	LRA	
RAF210 Vertical	208/230-3-60	STD/MED	5	60	—	—	—	—	89	100	93	490	101	125	107	510	
					454A	454A	18.8/25.0	52.1/60.1	89/91	100/100	93/93	490/490	101/106	125/125	107/107	510/510	
					455A	455A	37.6/50.0	104.2/120.3	146/136	150/150	135/153	490/490	161/151	175/175	148/167	510/510	
		456A	456A	56.3/75.0	156.4/180.4	172/196	200/225	195/222	490/490	187/211	200/225	208/236	510/510				
		HIGH	5	60	—	—	—	—	91	100	96	494	103	125	109	514	
					454A	454A	18.8/25.0	52.1/60.1	91/94	100/100	96/96	494/494	103/109	125/125	109/109	514/514	
	455A				455A	37.6/50.0	104.2/120.3	149/139	150/150	137/156	494/494	164/154	175/175	151/169	514/514		
	460-3-60	STD/MED	5	65	—	—	—	—	41	50	43	237	48	60	50	249	
					457A	457A	25.0	30.1	45	50	43	237	53	60	50	249	
					458A	458A	50.0	60.1	68	70	76	237	75	80	83	249	
		459A	459A	75.0	90.2	98	100	111	237	106	110	118	249				
		HIGH	5	65	—	—	—	—	42	50	44	239	49	60	52	251	
					457A	457A	25.0	30.1	46	50	44	239	54	60	52	251	
	458A				458A	50.0	60.1	69	80	77	239	77	80	84	251		
	575-3-60	STD/MED	5	—	—	—	—	—	32	40	33	186	36	45	39	194	
					460A	—	24.8	23.9	36	40	33	186	42	45	39	194	
					461A	—	49.6	47.7	66	70	61	186	72	80	66	194	
		462A	—	74.4	71.6	78	80	88	186	84	90	94	194				
		HIGH	5	—	—	—	—	—	33	40	34	186	38	45	40	194	
					460A	—	24.8	23.9	37	40	34	186	43	45	40	194	
	461A				—	49.6	47.7	67	70	62	186	73	80	67	194		
	462A	—	74.4	71.6	79	90	89	186	85	90	95	194					
	RAF210 Horizontal	208/230-3-60	HIGH	5	60	—	—	—	—	101	125	107	508	113	125	121	528
						463A	463A	18.8/25.0	52.1/60.1	101/107	125/125	107/107	508/508	113/121	125/125	121/121	528/528
464A						464A	37.6/50.0	104.2/120.3	162/152	175/175	149/167	508/508	176/167	200/175	162/181	528/528	
465A		465A	56.3/75.0	156.4/180.4	188/212	200/225	209/236	508/508	203/227	225/250	222/250	528/528					
460-3-60		HIGH	5	65	—	—	—	—	47	60	49	245	53	60	56	257	
					466A	466A	25.0	30.1	52	60	49	245	59	60	56	257	
					467A	467A	50.0	60.1	74	80	82	245	82	90	89	257	
					468A	468A	75.0	90.2	104	110	117	245	112	125	124	257	
575-3-60		HIGH	5	—	—	—	—	—	36	45	38	190	41	50	43	198	
					469A	—	24.8	23.9	41	45	38	190	47	50	44	198	
					470A	—	49.6	47.7	71	80	65	190	77	80	71	198	
					471A	—	74.4	71.6	83	90	93	190	89	90	98	198	

NOTE(S):

a. High SCCR (Short Circuit Current Rating) is not available on the following: units with Hot Gas Re-Heat system, Low Ambient controls, Phase loss monitor, Non-fused disconnect, or 575V models.

Electrical data (cont)

RAF210 MCA MOCP Electrical Data (cont)

RAF UNIT SIZE	NOM. V-P-Hz	IFM TYPE	STD SCCR KA	ELECTRIC HEATER			WITH POWERED CONVENIENCE OUTLET								
				STD SCCR CRHEATER ****00	NOM (kW)	FLA	No Power Exhaust				With Power Exhaust (powered from unit)				
							MCA	Fuse or HACR Breaker	Disconnect Size		MCA	Fuse or HACR Breaker	Disconnect Size		
									FLA	LRA			FLA	LRA	
RAF210 Vertical	208/230-3-60	STD/MED	5	—	—	—	94	125	99	495	106	125	112	515	
				454A	18.8/25.0	52.1/60.1	94/97	125/125	99/99	495/495	106/112	125/125	112/112	515/515	
				455A	37.6/50.0	104.2/120.3	152/142	175/150	140/159	495/495	167/157	175/175	154/172	515/515	
		456A	56.3/75.0	156.4/180.4	178/202	200/225	200/228	495/495	193/217	200/225	214/241	515/515			
		HIGH	5	—	—	—	96	125	101	499	108	125	115	519	
				454A	18.8/25.0	52.1/60.1	96/100	125/125	101/101	499/499	108/115	125/125	115/115	519/519	
	455A			37.6/50.0	104.2/120.3	155/145	175/150	143/161	499/499	170/160	175/175	156/175	519/519		
	460-3-60	STD/MED	5	—	—	—	44	50	46	239	50	60	53	251	
				457A	25.0	30.1	48	50	46	239	56	60	53	251	
				458A	50.0	60.1	70	80	79	239	78	80	86	251	
				459A	75.0	90.2	100	110	113	239	108	110	120	251	
		HIGH	5	—	—	—	45	50	47	241	51	60	54	253	
				457A	25.0	30.1	49	50	47	241	57	60	54	253	
				458A	50.0	60.1	72	80	80	241	79	80	87	253	
				459A	75.0	90.2	102	110	114	241	110	110	121	253	
		575-3-60	STD/MED	5	—	—	—	33	45	35	188	38	50	40	196
					460A	24.8	23.9	38	45	35	188	44	50	41	196
					461A	49.6	47.7	68	70	63	188	74	80	68	196
					462A	74.4	71.6	80	90	90	188	86	90	96	196
	HIGH	5	—	—	—	34	45	36	188	39	50	42	196		
			460A	24.8	23.9	40	45	36	188	46	50	42	196		
			461A	49.6	47.7	69	70	64	188	75	80	69	196		
			462A	74.4	71.6	81	90	91	188	87	90	97	196		
	RAF210 Horizontal	208/230-3-60	HIGH	5	—	—	—	106	125	113	513	118	150	127	533
463A					18.8/25.0	52.1/60.1	106/113	125/125	113/113	513/513	118/127	150/150	127/127	533/533	
464A					37.6/50.0	104.2/120.3	168/158	175/175	154/173	513/513	182/173	200/175	168/186	533/533	
465A					56.3/75.0	156.4/180.4	194/218	200/250	214/242	513/513	209/233	225/250	228/256	533/533	
460-3-60		HIGH	5	—	—	—	49	60	52	247	55	60	59	259	
				466A	25.0	30.1	54	60	52	247	62	70	59	259	
				467A	50.0	60.1	77	80	85	247	85	90	92	259	
				468A	75.0	90.2	107	125	119	247	115	125	126	259	
575-3-60		HIGH	5	—	—	—	38	45	40	192	42	50	45	200	
				469A	24.8	23.9	44	45	40	192	50	50	46	200	
				470A	49.6	47.7	73	80	67	192	79	80	73	200	
				471A	74.4	71.6	85	90	95	192	91	100	100	200	

Electrical data (cont)

RAF240 MCA MOCP Electrical Data

RAF UNIT SIZE	NOM. V-P-h-Hz	IFM TYPE	STD SCCR KA	HIGH SCCR KA ^a	ELECTRIC HEATER				NO CONVENIENCE OUTLET or UNPOWERED CONVENIENCE OUTLET								
					STD SCCR CRHEATER ****00	HIGH SCCR CRHEATER ****00	NOM (kW)	FLA	No Power Exhaust				With Power Exhaust (powered from unit)				
									MCA	Fuse or HACR Breaker	Disconnect Size		MCA	Fuse or HACR Breaker	Disconnect Size		
											FLA	LRA			FLA	LRA	
RAF240 Vertical	208/230-3-60	STD/MED	5	60	—	—	—	—	102	125	107	540	114	150	121	560	
					454A	454A	18.8/25.0	52.1/60.1	102/102	125/125	107/107	540/540	114/114	150/150	121/121	560/560	
					455A	455A	37.6/50.0	104.2/120.3	146/136	150/150	135/153	540/540	161/151	175/175	148/167	560/560	
		HIGH	5	60	456A	456A	56.3/75.0	156.4/180.4	172/196	200/225	195/222	540/540	187/211	200/225	208/236	560/560	
					—	—	—	—	115	150	121	558	126	150	135	578	
					454A	454A	18.8/25.0	52.1/60.1	115/115	150/150	121/121	558/558	126/126	150/150	135/135	578/578	
	460-3-60	STD/MED	5	65	—	—	—	—	48	60	50	296	54	60	58	308	
					457A	457A	25.0	30.1	48	60	50	296	54	60	58	308	
					458A	458A	50.0	60.1	68	70	76	296	75	80	83	308	
		HIGH	5	65	459A	459A	75.0	90.2	98	100	111	296	106	110	118	308	
					—	—	—	—	53	60	56	304	60	70	63	316	
					457A	457A	25.0	30.1	53	60	56	304	60	70	63	316	
	575-3-60	STD/MED	5	—	—	—	—	—	44	50	46	236	49	60	52	244	
					460A	—	24.8	23.9	40	50	42	232	45	50	47	240	
					461A	—	49.6	47.7	66	70	61	232	72	80	66	240	
		HIGH	5	—	462A	—	74.4	71.6	78	80	88	232	84	90	94	240	
					—	—	—	—	44	50	46	236	49	60	52	244	
					460A	—	24.8	23.9	44	50	46	236	49	60	52	244	
	RAF240 Horizontal	208/230-3-60	HIGH	5	60	—	—	—	—	115	150	121	558	126	150	135	578
						463A	463A	18.8/25.0	52.1/60.1	115/115	150/150	121/121	558/558	126/126	150/150	135/135	578/578
						464A	464A	37.6/50.0	104.2/120.3	162/152	175/175	149/167	558/558	176/167	200/175	162/181	578/578
			HIGH	5	65	465A	465A	56.3/75.0	156.4/180.4	188/212	200/225	209/236	558/558	203/227	225/250	222/250	578/578
						—	—	—	—	53	60	56	304	60	70	63	316
						466A	466A	25.0	30.1	53	60	56	304	60	70	63	316
460-3-60		HIGH	5	65	467A	467A	50.0	60.1	74	80	82	304	82	90	89	316	
					468A	468A	75.0	90.2	104	110	117	304	112	125	124	316	
					—	—	—	—	44	50	46	236	49	60	52	244	
		HIGH	5	—	469A	—	24.8	23.9	44	50	46	236	49	60	52	244	
					470A	—	49.6	47.7	71	80	65	236	77	80	71	244	
					471A	—	74.4	71.6	83	90	93	236	89	90	98	244	

NOTE(S):

- a. High SCCR (Short Circuit Current Rating) is not available on the following: units with Hot Gas Re-Heat system, Low Ambient controls, Phase loss monitor, Non-fused disconnect, or 575V models.

Electrical data (cont)

RAF240 MCA MOCP Electrical Data (cont)

RAF UNIT SIZE	NOM. V-Ph-Hz	IFM TYPE	STD SCCR KA	ELECTRIC HEATER			WITH POWERED CONVENIENCE OUTLET								
				STD SCCR CRHEATER ****00	NOM (kW)	FLA	No Power Exhaust				With Power Exhaust (powered from unit)				
							MCA	Fuse or HACR Breaker	Disconnect Size		MCA	Fuse or HACR Breaker	Disconnect Size		
									FLA	LRA			FLA	LRA	
RAF240 Vertical	208/230-3-60	STD/MED	5	—	—	—	107	125	112	545	119	150	126	565	
				454A	18.8/25.0	52.1/60.1	107/107	125/125	112/112	545/545	119/119	150/150	126/126	565/565	
				455A	37.6/50.0	104.2/120.3	152/142	175/150	140/159	545/545	167/157	175/175	154/172	565/565	
		456A	56.3/75.0	156.4/180.4	178/202	200/225	200/228	545/545	193/217	200/225	214/241	565/565			
		HIGH	5	—	—	—	120	150	127	563	131	150	140	583	
				454A	18.8/25.0	52.1/60.1	120/120	150/150	127/127	563/563	131/131	150/150	140/140	583/583	
	455A			37.6/50.0	104.2/120.3	168/158	175/175	154/173	563/563	182/173	200/175	168/186	583/583		
	460-3-60	STD/MED	5	—	—	—	50	60	53	298	56	70	60	310	
				457A	25.0	30.1	50	60	53	298	56	70	60	310	
				458A	50.0	60.1	70	80	79	298	78	80	86	310	
		459A	75.0	90.2	100	110	113	298	108	110	120	310			
		HIGH	5	—	—	—	56	60	59	306	62	70	66	318	
				457A	25.0	30.1	56	60	59	306	62	70	66	318	
	458A			50.0	60.1	77	80	85	306	85	90	92	318		
	575-3-60	STD/MED	5	—	—	—	42	50	44	234	46	60	49	242	
				460A	24.8	23.9	42	50	44	234	46	60	49	242	
				461A	49.6	47.7	68	70	63	234	74	80	68	242	
		462A	74.4	71.6	80	90	90	234	86	90	96	242			
		HIGH	5	—	—	—	46	60	48	238	50	60	54	246	
				460A	24.8	23.9	46	60	48	238	50	60	54	246	
	461A			49.6	47.7	73	80	67	238	79	80	73	246		
	RAF240 Horizontal	208/230-3-60	HIGH	5	—	—	—	120	150	127	563	131	150	140	583
					463A	18.8/25.0	52.1/60.1	120/120	150/150	127/127	563/563	131/131	150/150	140/140	583/583
					464A	37.6/50.0	104.2/120.3	168/158	175/175	154/173	563/563	182/173	200/175	168/186	583/583
465A			56.3/75.0	156.4/180.4	194/218	200/250	214/242	563/563	209/233	225/250	228/256	583/583			
HIGH			5	—	—	—	56	60	59	306	62	70	66	318	
				466A	25.0	30.1	56	60	59	306	62	70	66	318	
		467A		50.0	60.1	77	80	85	306	85	90	92	318		
460-3-60		HIGH	5	—	—	—	107	125	119	306	115	125	126	318	
				468A	75.0	90.2	107	125	119	306	115	125	126	318	
				—	—	—	46	60	48	238	50	60	54	246	
		HIGH	5	469A	24.8	23.9	46	60	48	238	50	60	54	246	
				470A	49.6	47.7	73	80	67	238	79	80	73	246	
				471A	74.4	71.6	85	90	95	238	91	100	100	246	

Electrical data (cont)

RAF300 MCA MOCP Electrical Data

RAF UNIT SIZE	NOM. V-P-Hz	IFM TYPE	STD SCCR KA	HIGH SCCR KA ^a	ELECTRIC HEATER				NO CONVENIENCE OUTLET or UNPOWERED CONVENIENCE OUTLET							
					STD SCCR CRHEATER ****00	HIGH SCCR CRHEATER ****00	NOM (kW)	FLA	No Power Exhaust				With Power Exhaust (powered from unit)			
									MCA	Fuse or HACR Breaker	Disconnect Size		MCA	Fuse or HACR Breaker	Disconnect Size	
											FLA	LRA			FLA	LRA
5RAF300 Vertical	208/230-3-60	STD/MED	5	60	—	—	—	—	123	150	129	574	135	175	142	594
					454A	454A	18.8/25.0	52.1/60.1	123/123	150/150	129/129	574/574	135/135	175/175	142/142	594/594
					455A	455A	37.6/50.0	104.2/120.3	149/139	150/150	137/156	574/574	164/154	175/175	151/169	594/594
					456A	456A	56.3/75.0	156.4/180.4	175/199	200/225	197/225	574/574	190/214	200/225	211/238	594/594
		HIGH	5	60	—	—	—	—	133	175	140	588	145	175	154	608
					454A	454A	18.8/25.0	52.1/60.1	133/133	175/175	140/140	588/588	145/145	175/175	154/154	608/608
					455A	455A	37.6/50.0	104.2/120.3	162/152	175/175	149/167	588/588	176/167	200/175	162/181	608/608
					456A	456A	56.3/75.0	156.4/180.4	188/212	200/225	209/236	588/588	203/227	225/250	222/250	608/608
	460-3-60	STD/MED	5	65	—	—	—	—	59	80	62	312	65	80	69	324
					457A	457A	25.0	30.1	59	80	62	312	65	80	69	324
					458A	458A	50.0	60.1	69	80	77	312	77	80	84	324
					459A	459A	75.0	90.2	99	100	112	312	107	110	119	324
		HIGH	5	65	—	—	—	—	63	80	67	318	70	90	74	330
					457A	457A	25.0	30.1	63	80	67	318	70	90	74	330
					458A	458A	50.0	60.1	74	80	82	318	82	90	89	330
					459A	459A	75.0	90.2	104	110	117	318	112	125	124	330
	575-3-60	STD/MED	5	—	—	—	—	—	43	50	45	234	48	60	50	242
					460A	—	24.8	23.9	43	50	45	234	48	60	50	242
					461A	—	49.6	47.7	67	70	62	234	73	80	67	242
					462A	—	74.4	71.6	79	90	89	234	85	90	95	242
		HIGH	5	—	—	—	—	—	46	60	49	238	51	60	54	246
					460A	—	24.8	23.9	46	60	49	238	51	60	54	246
					461A	—	49.6	47.7	71	80	65	238	77	80	71	246
					462A	—	74.4	71.6	83	90	93	238	89	90	98	246
RAF300 Horizontal	208/230-3-60	HIGH	5	60	—	—	—	—	133	175	140	588	145	175	154	608
					463A	463A	18.8/25.0	52.1/60.1	133/133	175/175	140/140	588/588	145/145	175/175	154/154	608/608
					464A	464A	37.6/50.0	104.2/120.3	162/152	175/175	149/167	588/588	176/167	200/175	162/181	608/608
					465A	465A	56.3/75.0	156.4/180.4	188/212	200/225	209/236	588/588	203/227	225/250	222/250	608/608
	460-3-60	HIGH	5	65	—	—	—	—	63	80	67	318	70	90	74	330
					466A	466A	25.0	30.1	63	80	67	318	70	90	74	330
					467A	467A	50.0	60.1	74	80	82	318	82	90	89	330
					468A	468A	75.0	90.2	104	110	117	318	112	125	124	330
	575-3-60	HIGH	5	—	—	—	—	—	46	60	49	238	51	60	54	246
					469A	—	24.8	23.9	46	60	49	238	51	60	54	246
					470A	—	49.6	47.7	71	80	65	238	77	80	71	246
					471A	—	74.4	71.6	83	90	93	238	89	90	98	246

NOTE(S):

- a. High SCCR (Short Circuit Current Rating) is not available on the following: units with Hot Gas Re-Heat system, Low Ambient controls, Phase loss monitor, Non-fused disconnect, or 575V models.

Electrical data (cont)

RAF300 MCA MOCP Electrical Data (cont)

RAF UNIT SIZE	NOM. V-Ph-Hz	IFM TYPE	STD SCCR KA	ELECTRIC HEATER			WITH POWERED CONVENIENCE OUTLET								
				STD SCCR CRHEATER ****00	NOM (kW)	FLA	No Power Exhaust				With Power Exhaust (powered from unit)				
							MCA	Fuse or HACR Breaker	Disconnect Size		MCA	Fuse or HACR Breaker	Disconnect Size		
									FLA	LRA			FLA	LRA	
RAF300 Vertical	208/230-3-60	STD/MED	5	—	—	—	128	150	134	579	140	175	148	599	
				454A	18.8/25.0	52.1/60.1	128/128	150/150	134/134	579/579	140/140	175/175	148/148	599/599	
				455A	37.6/50.0	104.2/120.3	155/145	175/150	143/161	579/579	170/160	175/175	156/175	599/599	
		456A	56.3/75.0	156.4/180.4	181/205	200/225	203/230	579/579	196/220	200/225	216/244	599/599			
		HIGH	5	—	—	—	138	175	146	593	150	175	159	613	
				454A	18.8/25.0	52.1/60.1	138/138	175/175	146/146	593/593	150/150	175/175	159/159	613/613	
	455A			37.6/50.0	104.2/120.3	168/158	175/175	154/173	593/593	182/173	200/175	168/186	613/613		
	460-3-60	STD/MED	5	—	—	—	61	80	64	314	68	80	72	326	
				457A	25.0	30.1	61	80	64	314	68	80	72	326	
				458A	50.0	60.1	72	80	80	314	79	80	87	326	
		459A	75.0	90.2	102	110	114	314	110	110	121	326			
		HIGH	5	—	—	—	66	80	69	320	72	90	76	332	
				457A	25.0	30.1	66	80	69	320	72	90	76	332	
	458A			50.0	60.1	77	80	85	320	85	90	92	332		
	575-3-60	STD/MED	5	—	—	—	44	50	47	236	49	60	52	244	
				460A	24.8	23.9	44	50	47	236	49	60	52	244	
				461A	49.6	47.7	69	70	64	236	75	80	69	244	
		462A	74.4	71.6	81	90	91	236	87	90	97	244			
		HIGH	5	—	—	—	48	60	50	240	52	60	56	248	
				460A	24.8	23.9	48	60	50	240	52	60	56	248	
	461A			49.6	47.7	73	80	67	240	79	80	73	248		
	RAF300 Horizontal	208/230-3-60	HIGH	5	—	—	—	138	175	146	593	150	175	159	613
					463A	18.8/25.0	52.1/60.1	138/138	175/175	146/146	593/593	150/150	175/175	159/159	613/613
					464A	37.6/50.0	104.2/120.3	168/158	175/175	154/173	593/593	182/173	200/175	168/186	613/613
465A			56.3/75.0	156.4/180.4	194/218	200/250	214/242	593/593	209/233	225/250	228/256	613/613			
HIGH			5	—	—	—	66	80	69	320	72	90	76	332	
				466A	25.0	30.1	66	80	69	320	72	90	76	332	
		467A		50.0	60.1	77	80	85	320	85	90	92	332		
460-3-60		HIGH	5	468A	75.0	90.2	107	125	119	320	115	125	126	332	
				—	—	—	48	60	50	240	52	60	56	248	
				469A	24.8	23.9	48	60	50	240	52	60	56	248	
		HIGH	5	470A	49.6	47.7	73	80	67	240	79	80	73	248	
				471A	74.4	71.6	85	90	95	240	91	100	100	248	
				—	—	—	48	60	50	240	52	60	56	248	

Electrical data (cont)

RAF336 MCA MOCP Electrical Data

RAF UNIT SIZE	NOM. V-P-Hz	IFM TYPE	STD SCCR kA	HIGH SCCR kA ^a	ELECTRIC HEATER				NO CONVENIENCE OUTLET or UNPOWERED CONVENIENCE OUTLET								
					STD SCCR CRHEATER ****00	HIGH SCCR CRHEATER ****00	NOM (kW)	FLA	No Power Exhaust				With Power Exhaust (powered from unit)				
									MCA	Fuse or HACR Breaker	Disconnect Size		MCA	Fuse or HACR Breaker	Disconnect Size		
											FLA	LRA			FLA	LRA	
RAF336 Vertical	208/230-3-60	STD/MED	5	60	—	—	—	—	139	175	146	640	151	200	159	660	
					454A	454A	18.8/25.0	52.1/60.1	139/139	175/175	146/146	640/640	151/151	200/200	159/159	660/660	
					455A	455A	37.6/50.0	104.2/120.3	149/139	175/175	146/156	640/640	164/154	200/200	159/169	660/660	
		HIGH	5	60	456A	456A	56.3/75.0	156.4/180.4	175/199	200/225	197/225	640/640	190/214	200/225	211/238	660/660	
					—	—	—	—	150	200	157	654	161	200	171	674	
					454A	454A	18.8/25.0	52.1/60.1	150/150	200/200	157/157	654/654	161/161	200/200	171/171	674/674	
	460-3-60	STD/MED	5	65	—	—	—	—	63	80	66	322	69	90	73	334	
					457A	457A	25.0	30.1	63	80	66	322	69	90	73	334	
					458A	458A	50.0	60.1	69	80	77	322	77	90	84	334	
		HIGH	5	65	459A	459A	75.0	90.2	99	100	112	322	107	110	119	334	
					—	—	—	—	67	80	71	328	73	90	78	340	
					457A	457A	25.0	30.1	67	80	71	328	73	90	78	340	
	575-3-60	STD/MED	5	—	—	—	—	—	54	60	57	238	59	70	62	246	
					460A	—	24.8	23.9	54	60	57	238	59	70	62	246	
					461A	—	49.6	47.7	67	70	62	238	73	80	67	246	
		HIGH	5	—	462A	—	74.4	71.6	79	90	89	238	85	90	95	246	
					—	—	—	—	58	70	60	242	62	80	66	250	
					460A	—	24.8	23.9	58	70	60	242	62	80	66	250	
	RAF336 Horizontal	208/230-3-60	HIGH	5	60	—	—	—	—	150	200	157	654	161	200	171	674
						463A	463A	18.8/25.0	52.1/60.1	150/150	200/200	157/157	654/654	161/161	200/200	171/171	674/674
						464A	464A	37.6/50.0	104.2/120.3	162/152	200/200	157/167	654/654	176/167	200/200	171/181	674/674
			HIGH	5	65	465A	465A	56.3/75.0	156.4/180.4	188/212	200/225	209/236	654/654	203/227	225/250	222/250	674/674
						—	—	—	—	67	80	71	328	73	90	78	340
						466A	466A	25.0	30.1	67	80	71	328	73	90	78	340
460-3-60		HIGH	5	65	467A	467A	50.0	60.1	74	80	82	328	82	90	89	340	
					468A	468A	75.0	90.2	104	110	117	328	112	125	124	340	
					—	—	—	—	58	70	60	242	62	80	66	250	
		HIGH	5	—	469A	—	24.8	23.9	58	70	60	242	62	80	66	250	
					470A	—	49.6	47.7	71	80	65	242	77	80	71	250	
					471A	—	74.4	71.6	83	90	93	242	89	90	98	250	

NOTE(S):

- a. High SCCR (Short Circuit Current Rating) is not available on the following: units with Hot Gas Re-Heat system, Low Ambient controls, Phase loss monitor, Non-fused disconnect, or 575V models.

Electrical data (cont)

RAF336 MCA MOCP Electrical Data (cont)

RAF UNIT SIZE	NOM. V-P-Hz	IFM TYPE	STD SCCR kA	ELECTRIC HEATER			WITH POWERED CONVENIENCE OUTLET							
				STD SCCR CRHEATER ****00	NOM (kW)	FLA	No Power Exhaust				With Power Exhaust (powered from unit)			
							MCA	Fuse or HACR Breaker	Disconnect Size		MCA	Fuse or HACR Breaker	Disconnect Size	
									FLA	LRA			FLA	LRA
RAF336 Vertical	208/230-3-60	STD/MED	5	—	—	—	144	175	151	645	156	200	165	665
				454A	18.8/25.0	52.1/60.1	144/144	175/175	151/151	645/645	156/156	200/200	165/165	665/665
				455A	37.6/50.0	104.2/120.3	155/145	175/175	151/161	645/645	170/160	200/200	165/175	665/665
		456A	56.3/75.0	156.4/180.4	181/205	200/225	203/230	645/645	196/220	200/225	216/244	665/665		
		HIGH	5	—	—	—	154	200	163	659	166	200	176	679
				454A	18.8/25.0	52.1/60.1	154/154	200/200	163/163	659/659	166/166	200/200	176/176	679/679
	455A			37.6/50.0	104.2/120.3	168/158	200/200	163/173	659/659	182/173	200/200	176/186	679/679	
	456A	56.3/75.0	156.4/180.4	194/218	200/250	214/242	659/659	209/233	225/250	228/256	679/679			
	460-3-60	STD/MED	5	—	—	—	65	80	68	324	71	90	75	336
				457A	25.0	30.1	65	80	68	324	71	90	75	336
				458A	50.0	60.1	72	80	80	324	79	90	87	336
		459A	75.0	90.2	102	110	114	324	110	110	121	336		
		HIGH	5	—	—	—	69	90	73	330	75	90	80	342
				457A	25.0	30.1	69	90	73	330	75	90	80	342
	458A			50.0	60.1	77	90	85	330	85	90	92	342	
	459A	75.0	90.2	107	125	119	330	115	125	126	342			
	575-3-60	STD/MED	5	—	—	—	56	70	59	240	61	80	64	248
				460A	24.8	23.9	56	70	59	240	61	80	64	248
				461A	49.6	47.7	69	70	64	240	75	80	69	248
		462A	74.4	71.6	81	90	91	240	87	90	97	248		
		HIGH	5	—	—	—	59	70	62	244	64	80	68	252
				460A	24.8	23.9	59	70	62	244	64	80	68	252
	461A			49.6	47.7	73	80	67	244	79	80	73	252	
	462A	74.4	71.6	85	90	95	244	91	100	100	252			
RAF336 Horizontal	208/230-3-60	HIGH	5	—	—	—	154	200	163	659	166	200	176	679
				463A	18.8/25.0	52.1/60.1	154/154	200/200	163/163	659/659	166/166	200/200	176/176	679/679
				464A	37.6/50.0	104.2/120.3	168/158	200/200	163/173	659/659	182/173	200/200	176/186	679/679
				465A	56.3/75.0	156.4/180.4	194/218	200/250	214/242	659/659	209/233	225/250	228/256	679/679
	460-3-60	HIGH	5	—	—	—	69	90	73	330	75	90	80	342
				466A	25.0	30.1	69	90	73	330	75	90	80	342
				467A	50.0	60.1	77	90	85	330	85	90	92	342
				468A	75.0	90.2	107	125	119	330	115	125	126	342
	575-3-60	HIGH	5	—	—	—	59	70	62	244	64	80	68	252
				469A	24.8	23.9	59	70	62	244	64	80	68	252
				470A	49.6	47.7	73	80	67	244	79	80	73	252
				471A	74.4	71.6	85	90	95	244	91	100	100	252

Electrical data (cont)

RAF210 Electric Heat Data — Standard SCCR Unit

RAF UNIT SIZE	NOM. V-Ph-Hz	IFM TYPE	STD SCCR kA	STD ELECTRIC HEATER PART NUMBER	NOMINAL (kW)	APPLICATION (kW)	APPLICATION OUTPUT (MBH)	STD SCCR SINGLE POINT OR JUNCTION KIT PART NUMBER CRSINGLEXXA00			
								No C.O. or Unpowered C.O.		With PWRD C.O.	
								No P.E.	With P.E. (pwrd fr/unit)	No P.E.	With P.E. (pwrd fr/unit)
RAF210 Vertical	208/230-3-60	STD/MED	5	CRHEATER454A00	25.0	18.8/23.0	64.1/78.3	—	—	—	—
				CRHEATER455A00	50.0	37.6/45.9	128.1/156.7	056	056	056	056
				CRHEATER456A00	75.0	56.3/68.9	192.2/235.0	056	056	056	056
		HIGH	5	CRHEATER454A00	25.0	18.8/23.0	64.1/78.3	—	—	—	—
				CRHEATER455A00	50.0	37.6/45.9	128.1/156.7	056	056	056	056
				CRHEATER456A00	75.0	56.3/68.9	192.2/235.0	056	056	056	056
	460-3-60	STD/MED	5	CRHEATER457A00	25.0	23.0	78.3	—	—	—	—
				CRHEATER458A00	50.0	45.9	156.7	—	057	057	057
				CRHEATER459A00	75.0	68.9	235.0	057	057	057	057
		HIGH	5	CRHEATER457A00	25.0	23.0	78.3	—	—	—	—
				CRHEATER458A00	50.0	45.9	156.7	057	057	057	057
				CRHEATER459A00	75.0	68.9	235.0	057	057	057	057
	575-3-60	STD/MED	5	CRHEATER460A00	24.8	22.8	77.7	—	—	—	—
				CRHEATER461A00	49.6	45.6	155.4	—	057	—	057
				CRHEATER462A00	74.4	68.3	233.1	057	057	057	057
		HIGH	5	CRHEATER460A00	24.8	22.8	77.7	—	—	—	—
				CRHEATER461A00	49.6	45.6	155.4	—	057	—	057
				CRHEATER462A00	74.4	68.3	233.1	057	057	057	057
RAF210 Horizontal	208/230-3-60	HIGH	5	CRHEATER463A00	25.0	18.8/23.0	64.1/78.3	—	—	—	056
				CRHEATER464A00	50.0	37.6/45.9	128.1/156.7	056	056	056	056
				CRHEATER465A00	75.0	56.3/68.9	192.2/235.0	056	056	056	056
	460-3-60	HIGH	5	CRHEATER466A00	25.0	23.0	78.3	—	—	—	—
				CRHEATER467A00	50.0	45.9	156.7	057	057	057	057
				CRHEATER468A00	75.0	68.9	235.0	057	057	057	057
	575-3-60	HIGH	5	CRHEATER469A00	24.8	22.8	77.7	—	—	—	—
				CRHEATER470A00	49.6	45.6	155.4	057	057	057	057
				CRHEATER471A00	74.4	68.3	233.1	057	057	057	057

RAF210 Electric Heat Data — High SCCR Unit

RAF UNIT SIZE	NOM. V-Ph-Hz	IFM TYPE	HIGH SCCR kA	HIGH SCCR ELECTRIC HEATER PART NUMBER	NOMINAL (kW)	APPLICATION (kW)	APPLICATION OUTPUT (MBH)	HIGH SCCR SINGLE POINT OR JUNCTION KIT PART NUMBER CRSINGLEXXA00	
								No C.O. or Unpowered C.O.	
								No P.E.	With P.E. (pwrd fr/unit)
RAF210 Vertical	208/230-3-60	STD/MED	60	CRHEATER454A00	25.0	18.8/23.0	64.1/78.3	—	—
				CRHEATER455A00	50.0	37.6/45.9	128.1/156.7	058	058
				CRHEATER456A00	75.0	56.3/68.9	192.2/235.0	058	058
		HIGH	60	CRHEATER454A00	25.0	18.8/23.0	64.1/78.3	—	—
				CRHEATER455A00	50.0	37.6/45.9	128.1/156.7	058	058
				CRHEATER456A00	75.0	56.3/68.9	192.2/235.0	058	058
	460-3-60	STD/MED	65	CRHEATER457A00	25.0	23.0	78.3	—	—
				CRHEATER458A00	50.0	45.9	156.7	—	059
				CRHEATER459A00	75.0	68.9	235.0	059	059
		HIGH	65	CRHEATER457A00	25.0	23.0	78.3	—	—
				CRHEATER458A00	50.0	45.9	156.7	059	059
				CRHEATER459A00	75.0	68.9	235.0	059	059
RAF210 Horizontal	208/230-3-60	HIGH	60	CRHEATER463A00	25.0	18.8/23.0	64.1/78.3	—	—
				CRHEATER464A00	50.0	37.6/45.9	128.1/156.7	058	058
				CRHEATER465A00	75.0	56.3/68.9	192.2/235.0	058	058
	460-3-60	HIGH	65	CRHEATER466A00	25.0	23.0	78.3	—	—
				CRHEATER467A00	50.0	45.9	156.7	059	059
				CRHEATER468A00	75.0	68.9	235.0	059	059

Electrical data (cont)

RAF240 Electric Heat Data — Standard SCCR Unit

RAF UNIT SIZE	NOM. V-Ph-Hz	IFM TYPE	STD SCCR kA	STD ELECTRIC HEATER PART NUMBER	NOMINAL (kW)	APPLICATION (kW)	APPLICATION OUTPUT (MBH)	STD SCCR SINGLE POINT OR JUNCTION KIT PART NUMBER CRSINGLEXXA00			
								No C.O. or Unpowered C.O.		With PWRD C.O.	
								No P.E.	With P.E. (pwrd fr/unit)	No P.E.	With P.E. (pwrd fr/unit)
RAF240 Vertical	208/230-3-60	STD/MED	5	CRHEATER454A00	25.0	18.8/23.0	64.1/78.3	—	056	—	056
				CRHEATER455A00	50.0	37.6/45.9	128.1/156.7	056	056	056	056
				CRHEATER456A00	75.0	56.3/68.9	192.2/235.0	056	056	056	056
		HIGH	5	CRHEATER454A00	25.0	18.8/23.0	64.1/78.3	056	056	056	056
				CRHEATER455A00	50.0	37.6/45.9	128.1/156.7	056	056	056	056
				CRHEATER456A00	75.0	56.3/68.9	192.2/235.0	056	056	056	056
	460-3-60	STD/MED	5	CRHEATER457A00	25.0	23.0	78.3	—	—	—	—
				CRHEATER458A00	50.0	45.9	156.7	—	057	057	057
				CRHEATER459A00	75.0	68.9	235.0	057	057	057	057
		HIGH	5	CRHEATER457A00	25.0	23.0	78.3	—	—	—	—
				CRHEATER458A00	50.0	45.9	156.7	057	057	057	057
				CRHEATER459A00	75.0	68.9	235.0	057	057	057	057
	575-3-60	STD/MED	5	CRHEATER460A00	24.8	22.8	77.7	—	—	—	—
				CRHEATER461A00	49.6	45.6	155.4	—	057	—	057
				CRHEATER462A00	74.4	68.3	233.1	057	057	057	057
		HIGH	5	CRHEATER460A00	24.8	22.8	77.7	—	—	—	—
				CRHEATER461A00	49.6	45.6	155.4	057	057	057	057
				CRHEATER462A00	74.4	68.3	233.1	057	057	057	057
RAF240 Horizontal	208/230-3-60	HIGH	5	CRHEATER463A00	25.0	18.8/23.0	64.1/78.3	056	056	056	056
				CRHEATER464A00	50.0	37.6/45.9	128.1/156.7	056	056	056	056
				CRHEATER465A00	75.0	56.3/68.9	192.2/235.0	056	056	056	056
	460-3-60	HIGH	5	CRHEATER466A00	25.0	23.0	78.3	—	—	—	—
				CRHEATER467A00	50.0	45.9	156.7	057	057	057	057
				CRHEATER468A00	75.0	68.9	235.0	057	057	057	057
	575-3-60	HIGH	5	CRHEATER469A00	24.8	22.8	77.7	—	—	—	—
				CRHEATER470A00	49.6	45.6	155.4	057	057	057	057
				CRHEATER471A00	74.4	68.3	233.1	057	057	057	057

RAF240 Electric Heat Data — High SCCR Unit

RAF UNIT SIZE	NOM. V-Ph-Hz	IFM TYPE	HIGH SCCR kA	HIGH SCCR ELECTRIC HEATER PART NUMBER	NOMINAL (kW)	APPLICATION (kW)	APPLICATION OUTPUT (MBH)	HIGH SCCR SINGLE POINT OR JUNCTION KIT PART NUMBER CRSINGLEXXA00	
								No C.O. or Unpowered C.O.	
								No P.E.	With P.E. (pwrd fr/unit)
RAF240 Vertical	208/230-3-60	STD/MED	60	CRHEATER454A00	25.0	18.8/23.0	64.1/78.3	—	058
				CRHEATER455A00	50.0	37.6/45.9	128.1/156.7	058	058
				CRHEATER456A00	75.0	56.3/68.9	192.2/235.0	058	058
		HIGH	60	CRHEATER454A00	25.0	18.8/23.0	64.1/78.3	058	058
				CRHEATER455A00	50.0	37.6/45.9	128.1/156.7	058	058
				CRHEATER456A00	75.0	56.3/68.9	192.2/235.0	058	058
	460-3-60	STD/MED	65	CRHEATER457A00	25.0	23.0	78.3	—	—
				CRHEATER458A00	50.0	45.9	156.7	—	059
				CRHEATER459A00	75.0	68.9	235.0	059	059
		HIGH	65	CRHEATER457A00	25.0	23.0	78.3	—	—
				CRHEATER458A00	50.0	45.9	156.7	059	059
				CRHEATER459A00	75.0	68.9	235.0	059	059
RAF240 Horizontal	208/230-3-60	HIGH	60	CRHEATER463A00	25.0	18.8/23.0	64.1/78.3	058	058
				CRHEATER464A00	50.0	37.6/45.9	128.1/156.7	058	058
				CRHEATER465A00	75.0	56.3/68.9	192.2/235.0	058	058
	460-3-60	HIGH	65	CRHEATER466A00	25.0	23.0	78.3	—	—
				CRHEATER467A00	50.0	45.9	156.7	059	059
				CRHEATER468A00	75.0	68.9	235.0	059	059

Electrical data (cont)

RAF300 Electric Heat Data — Standard SCCR Unit

RAF UNIT SIZE	NOM. V-Ph-Hz	IFM TYPE	STD SCCR kA	STD ELECTRIC HEATER PART NUMBER	NOMINAL (kW)	APPLICATION (kW)	APPLICATION OUTPUT (MBH)	STD SCCR SINGLE POINT OR JUNCTION KIT PART NUMBER CRSINGLEXXA00			
								No C.O. or Unpowered C.O.		With PWRD C.O.	
								No P.E.	With P.E. (pwrd fr/unit)	No P.E.	With P.E. (pwrd fr/unit)
RAF300 Vertical	208/230-3-60	STD/MED	5	CRHEATER454A00	25.0	18.8/23.0	64.1/78.3	056	056	056	056
				CRHEATER455A00	50.0	37.6/45.9	128.1/156.7	056	056	056	056
				CRHEATER456A00	75.0	56.3/68.9	192.2/235.0	056	056	056	056
		HIGH	5	CRHEATER454A00	25.0	18.8/23.0	64.1/78.3	056	056	056	056
				CRHEATER455A00	50.0	37.6/45.9	128.1/156.7	056	056	056	056
				CRHEATER456A00	75.0	56.3/68.9	192.2/235.0	056	056	056	056
	460-3-60	STD/MED	5	CRHEATER457A00	25.0	23.0	78.3	057	057	057	057
				CRHEATER458A00	50.0	45.9	156.7	057	057	057	057
				CRHEATER459A00	75.0	68.9	235.0	057	057	057	057
		HIGH	5	CRHEATER457A00	25.0	23.0	78.3	057	057	057	057
				CRHEATER458A00	50.0	45.9	156.7	057	057	057	057
				CRHEATER459A00	75.0	68.9	235.0	057	057	057	057
	575-3-60	STD/MED	5	CRHEATER460A00	24.8	22.8	77.7	—	—	—	—
				CRHEATER461A00	49.6	45.6	155.4	—	057	—	057
				CRHEATER462A00	74.4	68.3	233.1	057	057	057	057
		HIGH	5	CRHEATER460A00	24.8	22.8	77.7	—	—	—	—
				CRHEATER461A00	49.6	45.6	155.4	057	057	057	057
				CRHEATER462A00	74.4	68.3	233.1	057	057	057	057
RAF300 Horizontal	208/230-3-60	HIGH	5	CRHEATER463A00	25.0	18.8/23.0	64.1/78.3	056	056	056	056
				CRHEATER464A00	50.0	37.6/45.9	128.1/156.7	056	056	056	056
				CRHEATER465A00	75.0	56.3/68.9	192.2/235.0	056	056	056	056
	460-3-60	HIGH	5	CRHEATER466A00	25.0	23.0	78.3	057	057	057	057
				CRHEATER467A00	50.0	45.9	156.7	057	057	057	057
				CRHEATER468A00	75.0	68.9	235.0	057	057	057	057
	575-3-60	HIGH	5	CRHEATER469A00	24.8	22.8	77.7	—	—	—	—
				CRHEATER470A00	49.6	45.6	155.4	057	057	057	057
				CRHEATER471A00	74.4	68.3	233.1	057	057	057	057

RAF300 Electric Heat Data — High SCCR Unit

RAF UNIT SIZE	NOM. V-Ph-Hz	IFM TYPE	HIGH SCCR kA	HIGH SCCR ELECTRIC HEATER PART NUMBER	NOMINAL (kW)	APPLICATION (kW)	APPLICATION OUTPUT (MBH)	HIGH SCCR SINGLE POINT OR JUNCTION KIT PART NUMBER CRSINGLEXXA00	
								No C.O. or Unpowered C.O.	
								No P.E.	With P.E. (pwrd fr/unit)
RAF300 Vertical	208/230-3-60	STD/MED	60	CRHEATER454A00	25.0	18.8/23.0	64.1/78.3	058	058
				CRHEATER455A00	50.0	37.6/45.9	128.1/156.7	058	058
				CRHEATER456A00	75.0	56.3/68.9	192.2/235.0	058	058
		HIGH	60	CRHEATER454A00	25.0	18.8/23.0	64.1/78.3	058	058
				CRHEATER455A00	50.0	37.6/45.9	128.1/156.7	058	058
				CRHEATER456A00	75.0	56.3/68.9	192.2/235.0	058	058
	460-3-60	STD/MED	65	CRHEATER457A00	25.0	23.0	78.3	059	059
				CRHEATER458A00	50.0	45.9	156.7	059	059
				CRHEATER459A00	75.0	68.9	235.0	059	059
		HIGH	65	CRHEATER457A00	25.0	23.0	78.3	059	059
				CRHEATER458A00	50.0	45.9	156.7	059	059
				CRHEATER459A00	75.0	68.9	235.0	059	059
RAF300 Horizontal	208/230-3-60	HIGH	60	CRHEATER463A00	25.0	18.8/23.0	64.1/78.3	058	058
				CRHEATER464A00	50.0	37.6/45.9	128.1/156.7	058	058
				CRHEATER465A00	75.0	56.3/68.9	192.2/235.0	058	058
	460-3-60	HIGH	65	CRHEATER466A00	25.0	23.0	78.3	059	059
				CRHEATER467A00	50.0	45.9	156.7	059	059
				CRHEATER468A00	75.0	68.9	235.0	059	059

Electrical data (cont)

RAF336 Electric Heat Data — Standard SCCR Unit

RAF UNIT SIZE	NOM. V-Ph-Hz	IFM TYPE	STD SCCR kA	STD ELECTRIC HEATER PART NUMBER	NOMINAL (kW)	APPLICATION (kW)	APPLICATION OUTPUT (MBH)	STD SCCR SINGLE POINT OR JUNCTION KIT PART NUMBER CRSINGLEXXXA00			
								No C.O. or Unpowered C.O.		With PWRD C.O.	
								No P.E.	With P.E. (pwrd fr/unit)	No P.E.	With P.E. (pwrd fr/unit)
RAF336 Vertical	208/230-3-60	STD/MED	5	CRHEATER454A00	25.0	18.8/23.0	64.1/78.3	056	056	056	056
				CRHEATER455A00	50.0	37.6/45.9	128.1/156.7	056	056	056	056
				CRHEATER456A00	75.0	56.3/68.9	192.2/235.0	056	056	056	056
		HIGH	5	CRHEATER454A00	25.0	18.8/23.0	64.1/78.3	056	056	056	056
				CRHEATER455A00	50.0	37.6/45.9	128.1/156.7	056	056	056	056
				CRHEATER456A00	75.0	56.3/68.9	192.2/235.0	056	056	056	056
	460-3-60	STD/MED	5	CRHEATER457A00	25.0	23.0	78.3	057	057	057	057
				CRHEATER458A00	50.0	45.9	156.7	057	057	057	057
				CRHEATER459A00	75.0	68.9	235.0	057	057	057	057
		HIGH	5	CRHEATER457A00	25.0	23.0	78.3	057	057	057	057
				CRHEATER458A00	50.0	45.9	156.7	057	057	057	057
				CRHEATER459A00	75.0	68.9	235.0	057	057	057	057
	575-3-60	STD/MED	5	CRHEATER460A00	24.8	22.8	77.7	—	—	—	057
				CRHEATER461A00	49.6	45.6	155.4	—	057	—	057
				CRHEATER462A00	74.4	68.3	233.1	057	057	057	057
		HIGH	5	CRHEATER460A00	24.8	22.8	77.7	—	057	—	057
				CRHEATER461A00	49.6	45.6	155.4	057	057	057	057
				CRHEATER462A00	74.4	68.3	233.1	057	057	057	057
RAF336 Horizontal	208/230-3-60	HIGH	5	CRHEATER463A00	25.0	18.8/23.0	64.1/78.3	056	056	056	056
				CRHEATER464A00	50.0	37.6/45.9	128.1/156.7	056	056	056	056
				CRHEATER465A00	75.0	56.3/68.9	192.2/235.0	056	056	056	056
	460-3-60	HIGH	5	CRHEATER466A00	25.0	23.0	78.3	057	057	057	057
				CRHEATER467A00	50.0	45.9	156.7	057	057	057	057
				CRHEATER468A00	75.0	68.9	235.0	057	057	057	057
	575-3-60	HIGH	5	CRHEATER469A00	24.8	22.8	77.7	—	057	—	057
				CRHEATER470A00	49.6	45.6	155.4	057	057	057	057
				CRHEATER471A00	74.4	68.3	233.1	057	057	057	057

RAF336 Electric Heat Data — High SCCR Unit

RAF UNIT SIZE	NOM. V-Ph-Hz	IFM TYPE	HIGH SCCR kA	HIGH SCCR ELECTRIC HEATER PART NUMBER	NOMINAL (kW)	APPLICATION (kW)	APPLICATION OUTPUT (MBH)	HIGH SCCR SINGLE POINT OR JUNCTION KIT PART NUMBER CRSINGLEXXXA00	
								No C.O. or Unpowered C.O.	
								No P.E.	With P.E. (pwrd fr/unit)
RAF336 Vertical	208/230-3-60	STD/MED	60	CRHEATER454A00	25.0	18.8/23.0	64.1/78.3	058	058
				CRHEATER455A00	50.0	37.6/45.9	128.1/156.7	058	058
				CRHEATER456A00	75.0	56.3/68.9	192.2/235.0	058	058
		HIGH	60	CRHEATER454A00	25.0	18.8/23.0	64.1/78.3	058	058
				CRHEATER455A00	50.0	37.6/45.9	128.1/156.7	058	058
				CRHEATER456A00	75.0	56.3/68.9	192.2/235.0	058	058
	460-3-60	STD/MED	65	CRHEATER457A00	25.0	23.0	78.3	059	059
				CRHEATER458A00	50.0	45.9	156.7	059	059
				CRHEATER459A00	75.0	68.9	235.0	059	059
		HIGH	65	CRHEATER457A00	25.0	23.0	78.3	059	059
				CRHEATER458A00	50.0	45.9	156.7	059	059
				CRHEATER459A00	75.0	68.9	235.0	059	059
RAF336 Horizontal	208/230-3-60	HIGH	60	CRHEATER463A00	25.0	18.8/23.0	64.1/78.3	058	058
				CRHEATER464A00	50.0	37.6/45.9	128.1/156.7	058	058
				CRHEATER465A00	75.0	56.3/68.9	192.2/235.0	058	058
	460-3-60	HIGH	65	CRHEATER466A00	25.0	23.0	78.3	059	059
				CRHEATER467A00	50.0	45.9	156.7	059	059
				CRHEATER468A00	75.0	68.9	235.0	059	059

Typical wiring diagrams (cont)

RGF210-300 Power Wiring Diagram, Electromechanical with POL224 Controller

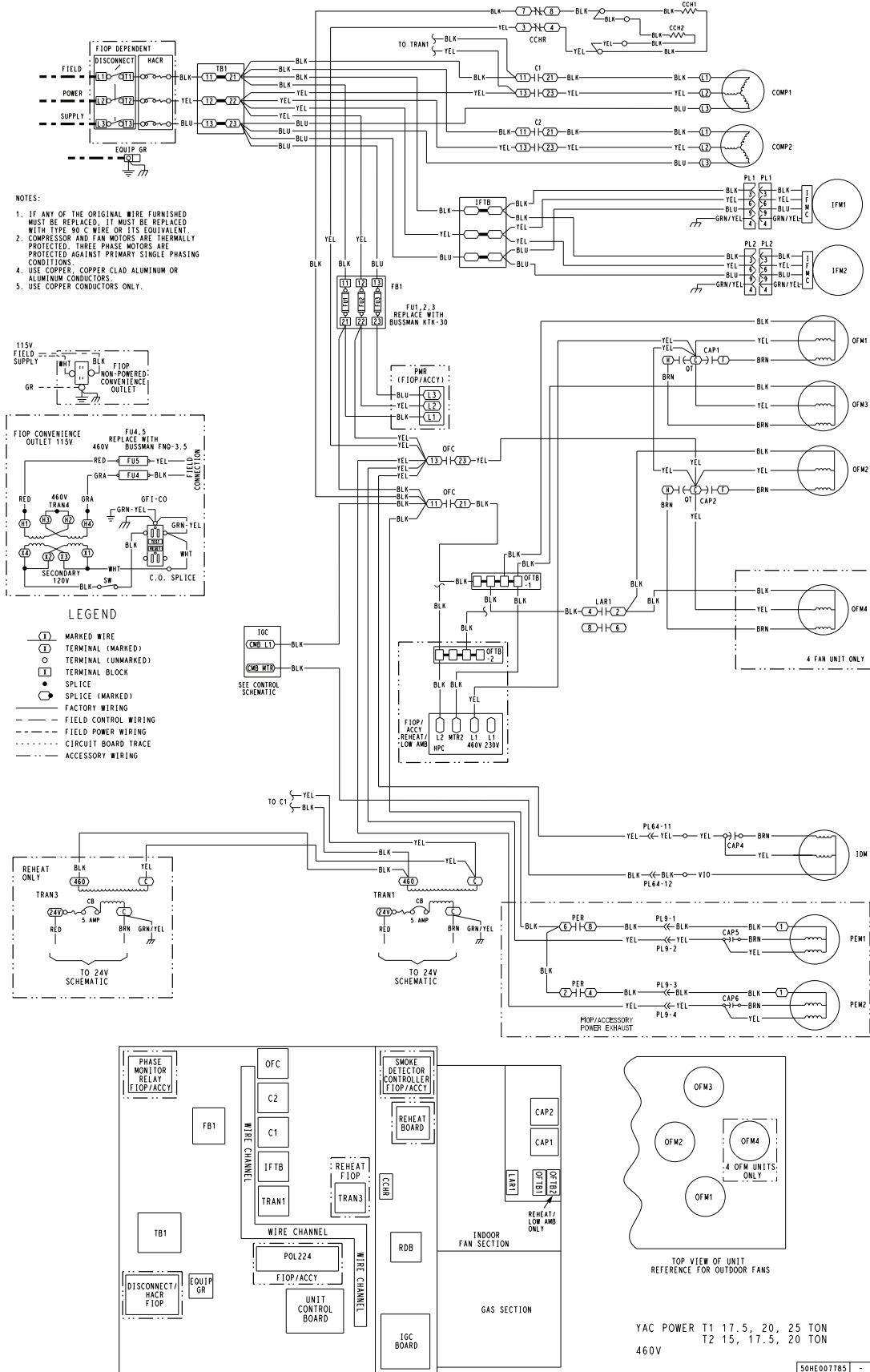

Typical wiring diagrams (cont)

RGF336 Power Wiring Diagram, Electromechanical with POL224 Controller

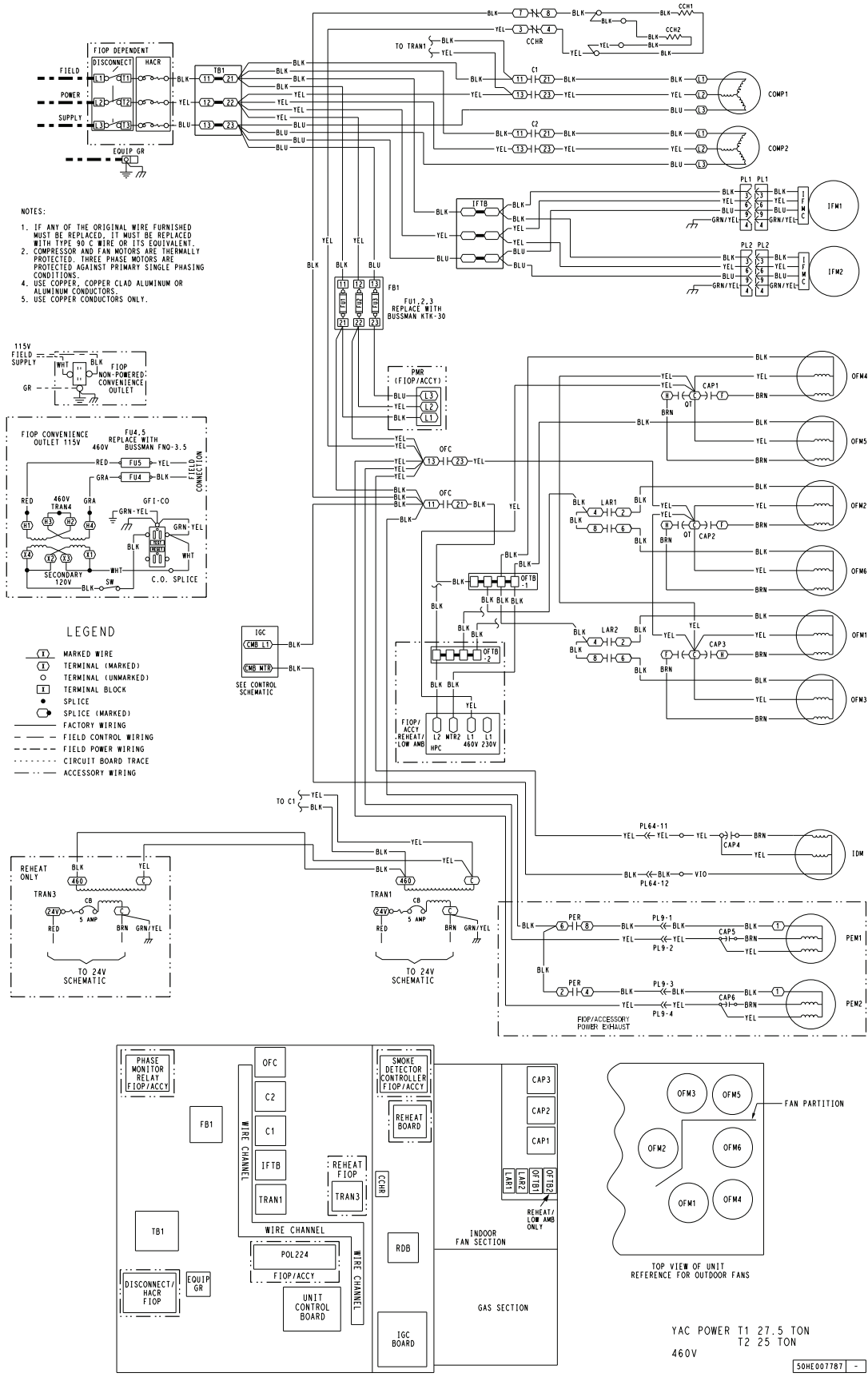

Typical wiring diagrams (cont)

RAF210-336 Control Wiring Diagram, Electromechanical with POL224 Controller

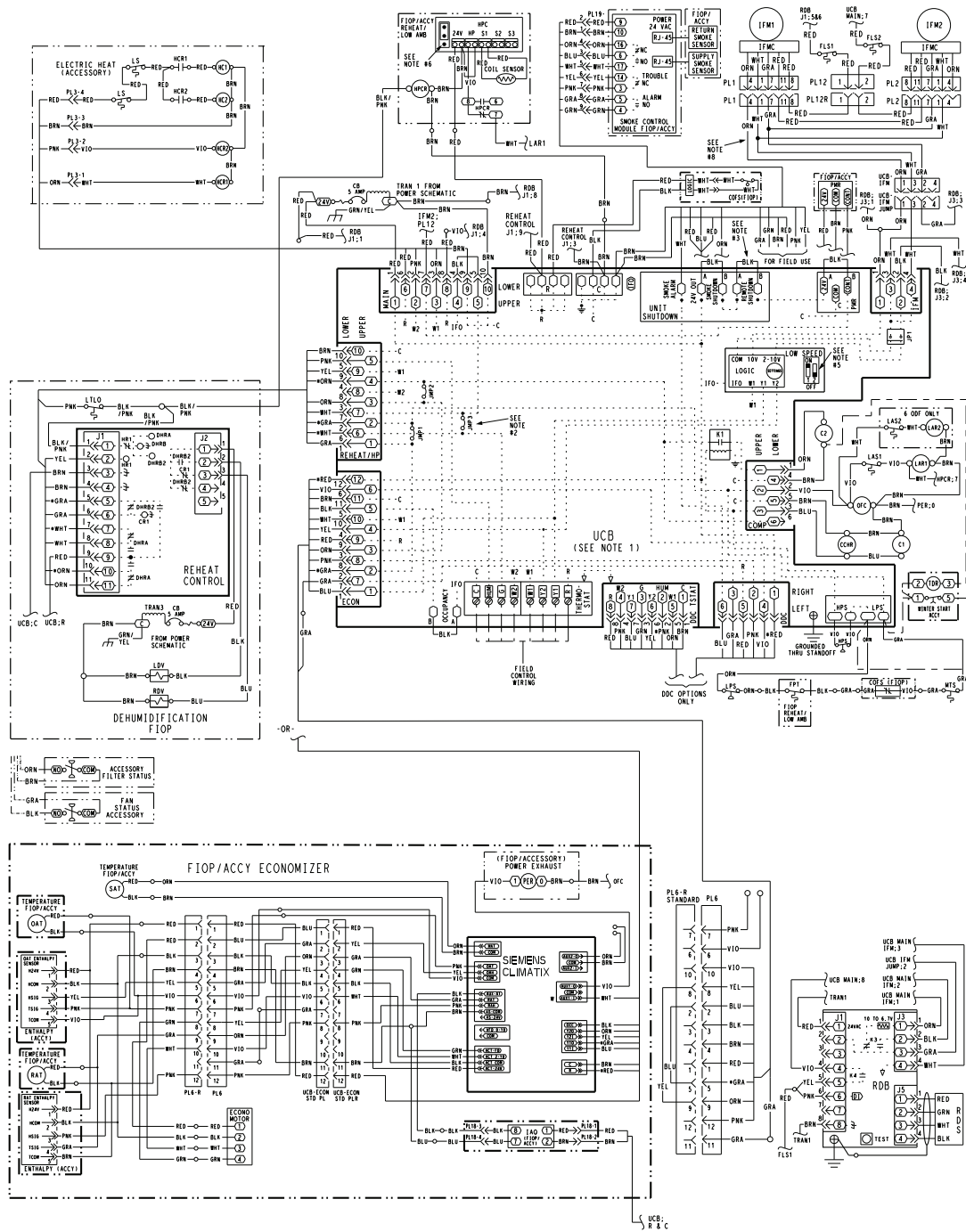

- NOTES:
- TERMINAL BOARD SCHEMATIC LAYOUT DOES NOT MATCH ACTUAL TERMINAL BOARD LAYOUT.
 - TERMINAL BOARD JUMPERS 1, 2 AND 3 ARE CUT FOR REHEAT UNITS ONLY.
 - REMOVE DESIGNATED JUMPERS ON TERMINAL BOARD WHEN ADDING SMOKE DETECTORS, OCCUPANCY AND REMOTE SHUTDOWN.
 - USE ABC AS COARSE AND POT AS FINE ADJUSTMENTS FOR SETTING HIGH FAN SPEED. LOW SPEED IS AN OFFSET BASED ON DIP SWITCHES.
 - 2-PIN LOW SPEED DIP SWITCH POSITIONS ARE FACTORY SET AS SHOWN. EXCEPT FOR 11.25 TON, POSITIONS WILL BE 1-OFF AND 2-ON.
 - HARDSTART AND CUTOFF SET TO "MIN". JUMPER PIN ON TOP 2-PINS AS SHOWN.
 - THE 4 WIRE COLOR IS FOR DIFFERENTIAL BOARD WITHIN THIS SCHEMATIC.
 - ON HORIZONTAL SUPPLY UNITS: IFM2 GRN AND WHT WIRES WILL INCLUDE IN-LINE RESISTORS TO REDUCE 11'S SPEED.
 - CONTROL BOARDS SHOWN HERE ARE IN THE UNPOWERED STATE.
- | | | | | | |
|------|------------------------------|------|-------------------------------|------|--------------------------------|
| ACCY | ACCESSORY | HS | HALL EFFECT SENSOR | OFM | OUTDOOR FAN MOTOR |
| AMB | AMBIENT | I | IGNITOR | OFR | OUTDOOR FAN RELAY |
| C | CONTACTOR/COMPRESSOR | IAD | INDOOR AIR QUALITY SENSORS | OL | OVERLOAD |
| CAP | CAPACITOR | IDM | INDUCED DRAFT MOTOR | PL | PLUS ASSEMBLY |
| CB | CIRCUIT BREAKER | IFCB | INDOOR FAN CIRCUIT BREAKER | POT | POTENTIOMETER |
| CH | CRANKCASE HEATER | IFM | INDOOR FAN MOTOR | PRM | PHASE MONITOR RELAY |
| CCHR | CRANKCASE HEATER RELAY | IFMC | INDOOR FAN CONTROLLER | QT | QUADRUPEL TERMINAL |
| CMB | COMBUSTION | IGC | INTEGRATED GAS CONTROL | RARH | RETURN AIR RELATIVE HUMIDITY |
| COS | CONDENSATE OVERFLOW SWT | JMP | JUMPER | RET | RETURN AIR TEMP. SENSOR |
| COMP | COMPRESSOR MOTOR | LA | LOW AMBIENT | RDB | REFRIGERANT DISSIPATION BOARD |
| DC | DIRECT DIGITAL CONTROL | LDV | LIQUID DIVERTER VALVE | RDS | REFRIGERANT DISSIPATION SENSOR |
| ERV | ENERGY RECOVERY VENTILATOR | LS | LIMIT SWITCH (MANUAL RESET) | RDV | REFRIGERANT DISCHARGE VALVE |
| FIOP | FACTORY INSTALLED OPTION | LSM | LIMIT SWITCH | RS | ROLLOUT SWITCH |
| FLS | FREEZE PROTECTION THERMOSTAT | LTLO | LOW TEMPERATURE LOCKOUT | SAT | SUPPLY AIR TEMP. SENSOR |
| FSD | FIRE SHUT DOWN | LV | LOW VOLTAGE RESTRICTOR | SEN | SENSOR |
| FS | FLAME SENSOR | MV | MIXED AIR TEMPERATURE SWITCH | SPRH | SPACE RELATIVE HUMIDITY |
| FU | FUSE | MTR | MOTOR | SPT | SPACE TEMPERATURE SENSOR |
| GN | GROUND | MTS | MIXED AIR TEMPERATURE SWITCH | SPO | SPACE TEMPERATURE OFFSET |
| GND | GROUND | OAG | OUTDOOR AIR QUALITY | STD | STANDARD |
| GVR | GAS VALVE RELAY | OARH | OUTDOOR AIR RELATIVE HUMIDITY | TB | TERMINAL BLOCK |
| HPC | HEAD PRESSURE CONTROL | OAT | OUTDOOR AIR TEMP. SENSOR | TDR | TIME DELAY RELAY(WINTER START) |
| HPS | HIGH PRESSURE SWITCH | | | TRAN | TRANSFORMER |
| | | | | UCB | UNIT CONTROL BOARD |
- PAC CONTROL
T1 17.5 - 27.5 TON
T2 15 - 25 TON
460V, 575V
- 50HQ007753 A

Typical wiring diagrams (cont)

RAF210-300 Power Wiring Diagram, Electromechanical with POL224 Controller

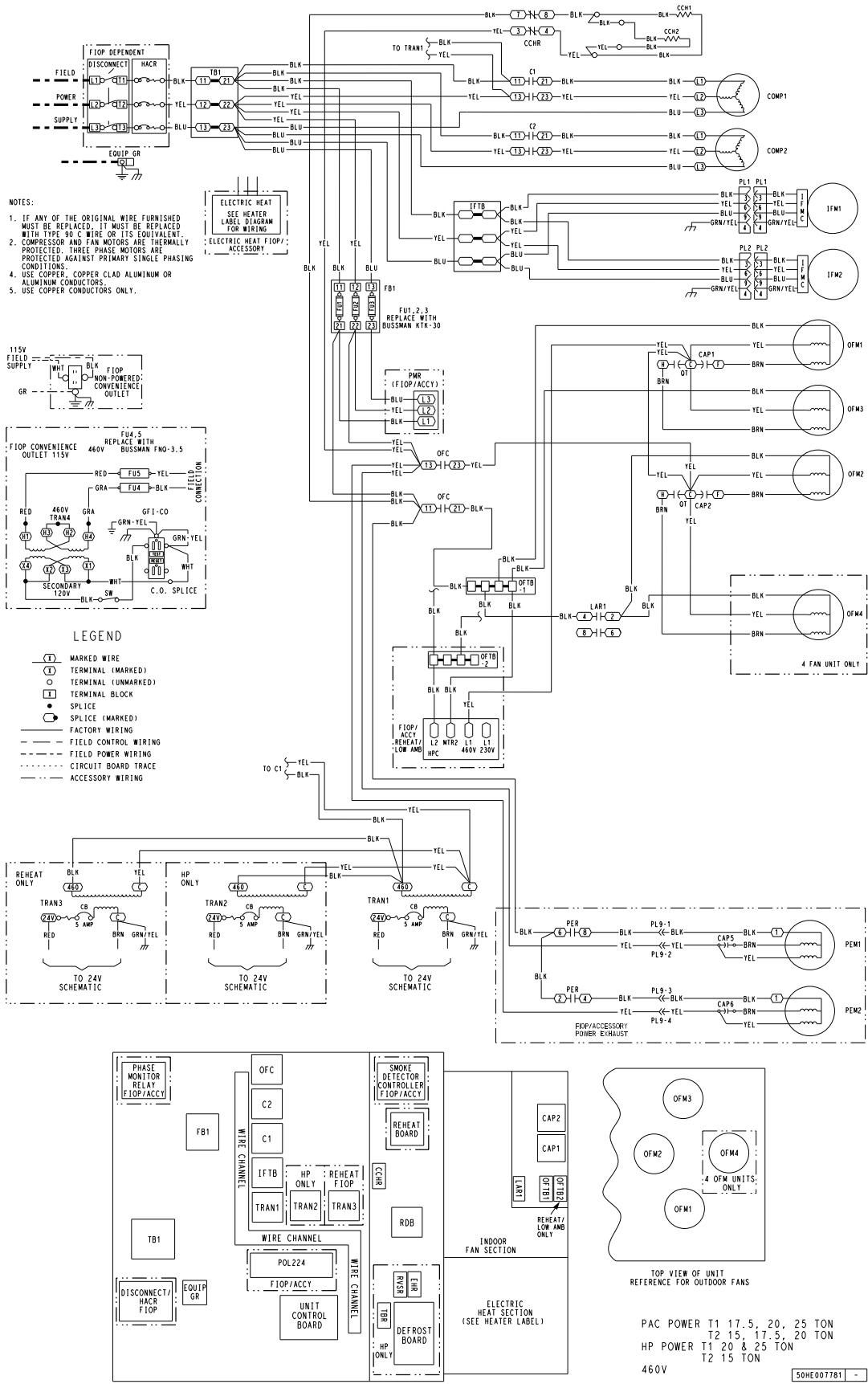

Typical wiring diagrams (cont)

RAF336 Power Wiring Diagram, Electromechanical with POL224 Controller

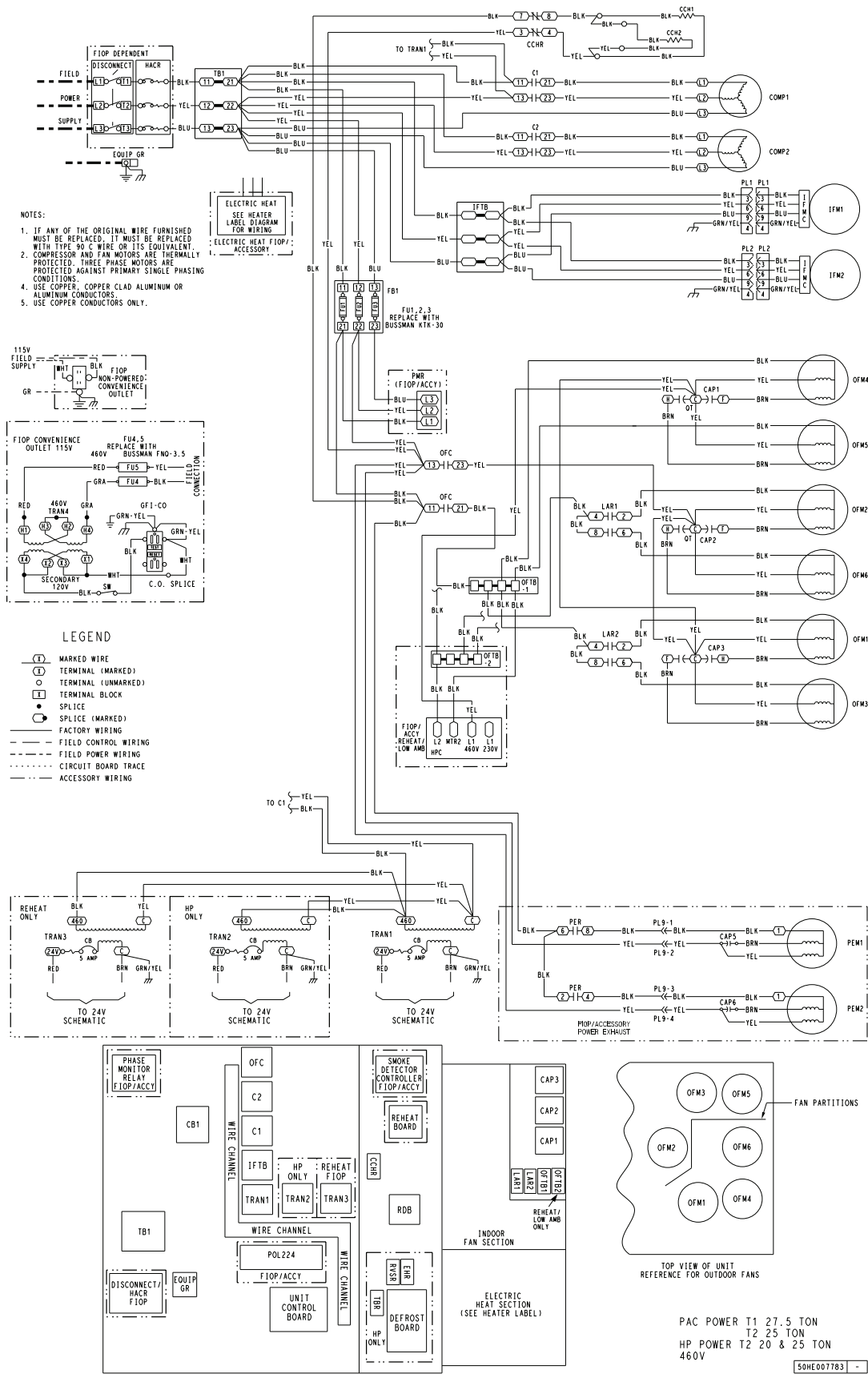

Sequence of operation

General

The sequence below describes the sequence of operation for an electromechanical unit with and without a factory-installed EconomizerONE (POL224 controller). For information regarding a direct digital controller, see the start-up, operations, and troubleshooting manual for the applicable controller.

Electromechanical Units without Economizer

Cooling (2-stage units)

When the thermostat calls for cooling, terminals G and Y1 are energized. The indoor fan will run at the low fan speed and the C1 compressor contactor (CC) is energized causing the compressor and outdoor fan to run. The low indoor fan speed is 60% or 66% of the user set fan speed depending on unit size.

If additional cooling is needed, the thermostat will add the call for Y2. This will increase the indoor fan speed to the user set fan speed and energize the C2 contactor and second compressor for full compressor capacity. The outdoor fan is the same speed for Y1 and Y2.

When the thermostat removes the call for Y2 but leaves the Y1, the indoor fan will slow to the reduced percentage of the user set fan speed, the C2 contactor will de-energize, the second compressor will turn off, and the outdoor fan will remain on. When the thermostat removes the call for Y1 the compressor contactor will de-energize shutting down the compressor and the outdoor fan. When the thermostat removes the call for G, the indoor fan will turn off after the specific unit fan off delay.

NOTE: Per ASHRAE 90.1-2019 and IECC-2018 standards, during the first stage cooling operation the Unit Control Board (UCB) will adjust the fan motor speed to provide 60% or 66% of the total cfm established for the unit.

Gas Heating (RGF units)

NOTE: RGF units have 2 stages of gas heat.

When the thermostat calls for heating, power is sent to W on the Integrated Gas Controller (IGC) board. An LED (light-emitting diode) on the IGC board turns on and remains on during normal operation. A check is made to ensure that the roll-out switch and limit switch are closed. If the check was successful, the induced-draft motor is energized, and when its speed is satisfactory, as proven by the flue gas pressure switch, the ignition activation period begins. The burners will ignite within 5 seconds. If the burners do not light, there is a 22 second delay before another 5 second attempt. This sequence is repeated for 15 minutes or until the burners light. If, after the 15 minutes, the burners still have not lit, heating is locked out. To reset the control, break 24-v power to the thermostat.

When ignition occurs, the IGC board will continue to monitor the condition of the roll-out switch, the limit switches, the flue gas pressure switch, as well as the flame sensor. 45 seconds after ignition occurs, assuming the unit is controlled through a room thermostat set for fan auto, the indoor-fan motor will energize (and the outdoor-air dampers will open to their minimum position). If, for some reason, the over-temperature limit opens prior to the start of the indoor

fan blower, the unit will shorten the 45 second delay to 5 seconds less than the time from initiation of heat to when the limit tripped. Gas will not be interrupted to the burners and heating will continue. Once the fan-on delay has been modified, it will not change back to 45 seconds until power is reset to the control. On units with 2 stages of heat, when additional heat is required, W2 closes and initiates power to the second stage of the main gas valve. When the thermostat is satisfied, W1 and W2 open and the gas valve closes, interrupting the flow of gas to the main burners. If the unit is controlled through a room thermostat set for fan auto, the indoor-fan motor will continue to operate for an additional 45 seconds then stop. A LED indicator is provided on the IGC to monitor operation.

Electric Heating (RAF units)

NOTE: RAF units are sold as cooling only. If electric heaters are required, use only factory-approved heaters. They will operate as follows.

Units have either 1 or 2 stages of electric heat. When the thermostat calls for heating, power is applied to G and the W1 terminals at the unit. The unit control will energize the indoor fan contactor and the first stage of electric heat. On units with 2-stage heating, when additional heating is required, the second stage of electric heat (if equipped) will be energized when power is applied at the W2 terminal on the unit.

IMPORTANT: The thermostat must be configured for Electric Heat so it will energize G with the W1 call.

Electromechanical Units with Factory-Installed EconomizerONE

When free cooling is not available, the compressors will be controlled by the zone thermostat. When free cooling is available, the outdoor-air damper is modulated by the EconomizerONE control to provide a 50°F (10°C) to 55°F (13°C) mixed-air temperature into the zone. As the mixed air temperature fluctuates above 55°F (13°C) or below 50°F (10°C) dampers will be modulated (open or close) to bring the mixed-air temperature back within control. If mechanical cooling is utilized with free cooling, the outdoor-air damper will maintain its current position at the time the compressor is started. If the increase in cooling capacity causes the mixed-air temperature to drop below 45°F (7°C), then the outdoor-air damper position will be decreased to the minimum position. If the mixed-air temperature continues to fall, the outdoor-air damper will close. Control returns to normal once the mixed-air temperature rises above 48°F (9°C). The power exhaust fans will be energized and de-energized, if installed, as the outdoor-air damper opens and closes.

If field-installed accessory CO₂ sensors are connected to the EconomizerONE control, a demand controlled ventilation strategy will begin to operate. As the CO₂ level in the zone increases above the CO₂ setpoint (on the EconomizerONE controller), the minimum position of the damper will be increased proportionally until the Maximum Ventilation setting is reached. As the CO₂ level decreases because of the increase in fresh air, the outdoor-air damper will follow the higher demand condition from either the DCV mode or from the free cooling mode. For

Sequence of operation (cont)

EconomizerONE operation, there must be a thermostat call for the fan (G). If the unit is occupied and the fan is on, the damper will operate at minimum position. Otherwise, the damper will be closed.

When the EconomizerONE control is in the occupied mode and a call for cooling exists (Y1 on the thermostat), the control will first check for indoor fan operation. If the fan is not on, then cooling will not be activated. If the fan is on, then the control will open the EconomizerONE damper to the minimum position.

On the initial power to the EconomizerONE control, it will take the damper up to 2 1/2 minutes before it begins to position itself. After the initial power-up, further changes in damper position can take up to 90 seconds to initiate. Damper movement from full closed to full open (or vice versa) will take between 1 1/2 and 2 1/2 minutes. If free cooling can be used as determined from the appropriate changeover command (dry bulb, outdoor enthalpy, differential dry bulb, or differential enthalpy), then the control will modulate the dampers open and closed to maintain the mixed-air temperature setpoint at 50°F (10°C) to 55°F (13°C). If there is a further demand for cooling (cooling second stage — Y2 is energized), then the control will bring on compressor stage 1 to maintain the mixed-air temperature setpoint. The EconomizerONE damper will be open at maximum position.

2-Speed Note: The EconomizerONE controller will adjust the damper position as the Indoor Fan Speed changes, per its configured values.

Heating

The sequence of operation for heating is the same as an electromechanical unit without an economizer. The only difference is how the economizer acts. The economizer will stay at the Economizer Minimum Position while the evaporator fan is operating. The outdoor-air damper is closed when the indoor fan is not operating. Refer to Service and Maintenance manual for further details.

Optional Hot Gas Re-Heat dehumidification system

Units with the factory equipped Hot Gas Re-Heat system option are capable of providing multiple modes of improved dehumidification as a variation of the normal cooling cycle. The Hot Gas Re-Heat system option includes additional valves in the liquid line and discharge line of each refrigerant circuit, a small reheat condenser coil downstream of the evaporator, and variable-speed control of some or all outdoor fans. Operation of the revised refrigerant circuit for each mode is described below.

The Hot Gas Re-Heat system provides 3 sub-modes of operation: Cool, Reheat1, and Reheat2.

Cool mode — Provides a normal ratio of Sensible and Latent Cooling effect from the evaporator coil.

Reheat1 — Provides increased Latent Cooling while slightly reducing the Sensible Cooling effect.

Reheat2 — Provides normal Latent Cooling but with null or minimum Sensible Cooling effect delivered to the space.

The Reheat1 and Reheat2 modes are available when the unit is not in a Heating mode and when the Low Ambient Lockout switch is closed.

Refer to the following figures for piping flow diagrams.

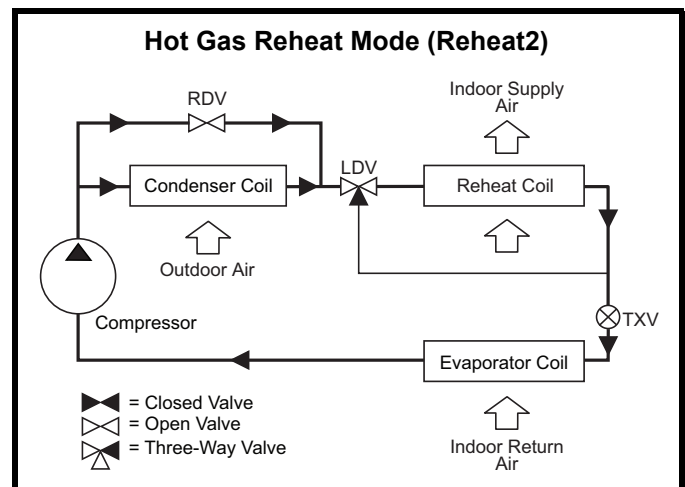
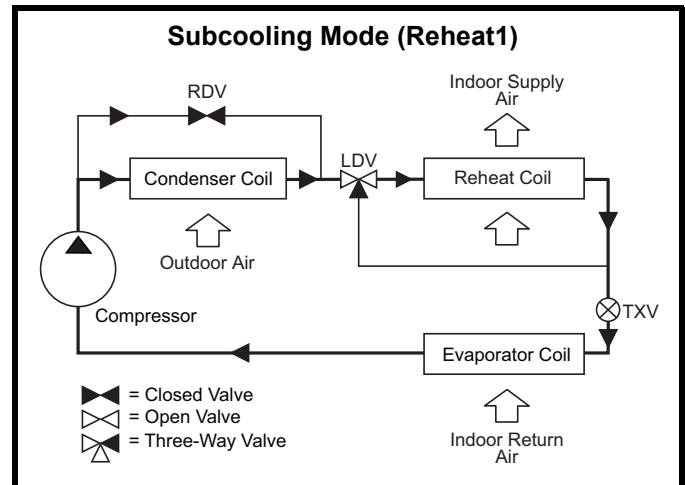
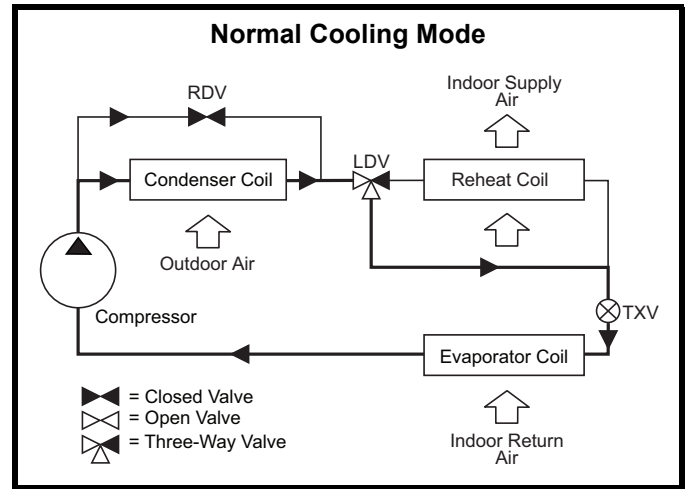

LEGEND

- LDV — Liquid Diverter Valve
- RDV — Reheat Discharge Valve
- TXV — Thermostatic Expansion Valve

Application data

Minimum operating ambient temperature (cooling)

In mechanical cooling mode, your RGF/RAF rooftop unit can safely operate down to an outdoor ambient temperature of 40°F (4°C). It is possible to provide cooling at lower outdoor ambient temperatures by using less outside air, economizers, and/or accessory low ambient kits.

Maximum operating ambient temperature (cooling)

The maximum operating ambient temperature for cooling mode is 115°F (46°C). While cooling operation above 115°F (46°C) may be possible, it could cause either a reduction in performance, reliability, or a protective action by the unit's internal safety devices.

Multiple motor and drive packages

Some applications need larger horsepower motors, some need more airflow, and some need both. Regardless of the case, your RGF/RAF expert has a factory installed combination to meet your application. A wide selection of motors are available, factory installed, to handle nearly any application.

Stainless steel heat exchanger (RGF units only)

The stainless steel heat exchanger option provides the tubular heat exchanger be made out of a minimum 20 gauge type 409 stainless steel for applications where the mixed air to the heat exchanger is expected to drop below 45°F (7°C). Stainless steel may be specified on applications where the presence of airborne contaminants require its use (applications such as paper mills) or in area with very high outdoor humidity that may result in severe condensation in the heat exchanger during cooling operation.

Minimum mixed air temperature (heating) (RGF units only)

Using the factory settings, the minimum temperatures for the mixed air (the combined temperature of the warm return air and the cold outdoor air) entering the dimpled, gas heat exchangers are shown in the following table.

Minimum Temperature for Mixed Air Temperature

ALUMINIZED	STAINLESS STEEL
50°F (10°C) Continuous	40°F (4°C) Continuous
45°F (7°C) Intermittent	35°F (2°C) Intermittent

Operating at lower mixed-air temperatures may be possible, if a field-supplied, outdoor air thermostat initiates both heat stages when the temperature is less than the minimum temperatures listed above. Please contact your local representative for assistance.

Minimum and maximum airflow (heating and cooling)

To maintain safe and reliable operation of your rooftop, operate within the heating airflow limits during heating mode and cooling airflow limits during cooling mode. Operating above the maximum may cause blow-off, undesired airflow noise, or airflow related problems with the rooftop unit. Operating below the minimum may cause problems with coil freeze-up and unsafe heating operation. Heating and cooling limitations differ when evaluating operating cfm, minimum value is the HIGHER

of the cooling and heating minimum cfm values published on page 7 and the maximum value is the LOWER of the cooling and heating minimum values published on page 7.

Heating-to-cooling changeover

Your unit will automatically change from heating to cooling mode when using a thermostat with an auto-change-over feature.

Airflow

All units are draw-through in cooling mode and blow-through in heating mode.

Outdoor air application strategies

Economizers reduce operating expenses and compressor run time by providing a free source of cooling and a means of ventilation to match application changing needs. In fact, they should be considered for most applications. Also, consider the various economizer control methods and their benefits, as well as sensors required to accomplish your application goals. Please contact your local representative for assistance.

Motor limits, brake horsepower (bhp)

Due to internal design of RGF/RAF units, the air path, and specially designed motors, the full horsepower (maximum continuous bhp) band, as listed in the Fan Performance tables, can be used with the utmost confidence. There is no need for extra safety factors, as RGF/RAF motors are designed and rigorously tested to use the entire, listed bhp range without either nuisance tripping or premature motor failure.

Propane heating (RGF units only)

Propane has different physical qualities than natural gas. As a result, propane requires different fuel to air mixture. To optimize the fuel/air mixture for propane, we sell different burner orifices in an easy to install accessory kit. To select the correct burner orifices or determine the heat capacity for a propane application, use either the selection software, or the unit's service manual.

High altitude heating

High altitudes have less oxygen, which affects the fuel/air mixture in heat exchangers. In order to maintain a proper fuel/air mixture, heat exchangers operating in altitudes above 2000 ft (610 m) require different orifices. To select the correct burner orifices or determine the heat capacity for a high altitude application, use either the selection software, or the unit's service manual.

High altitudes have less oxygen, which means heat exchangers need less fuel. The new gas orifices in this field-installed kit make the necessary adjustment for high altitude applications. They restore the optimal fuel to air mixture and maintain healthy combustion on altitudes above 2000 ft (610 m).

NOTE: Typical natural gas heating value ranges from 975 to 1050 Btu/ft³ at sea level nationally. The heating value goes down approximately 1.7% per every thousand feet elevation. Standard factory orifices can typically be used up to 2000 ft (610 m) elevation without any operational issues.

Application data (cont)

Sizing a rooftop

Bigger is not necessarily better. While an air conditioner needs to have enough capacity to meet the design loads, it does not need excess capacity. In fact, excess capacity typically results in very poor part load performance and humidity control.

Using higher design temperatures than ASHRAE recommends for your location, adding “safety factors” to the calculated load, are all signs of oversizing air conditioners. Oversizing the air conditioner leads to poor humidity control, reduced efficiency, higher utility bills, larger indoor temperature swings, excessive noise, and increased wear and tear on the air conditioner.

Rather than oversizing an air conditioner, engineers should “right-size” or even slightly “under-size” air conditioners. Correctly sizing an air conditioner controls humidity better; promotes efficiency; reduces utility bills;

extends equipment life, and maintains even, comfortable temperatures. Please contact your local representative for assistance.

Low ambient applications

The optional economizer can adequately cool your space by bringing in fresh, cool outside air. In fact, when so equipped, accessory low-ambient kit may not be necessary. In low ambient conditions, unless the outdoor air is excessively humid or contaminated, economizer-based “free cooling” is the preferred less costly and energy conscious method. In low ambient applications where outside air might not be desired (such as contaminated or excessively humid outdoor environments), your RGF/RAF rooftop can operate to ambient temperatures down to -0°F (-18°C) using the recommended accessory low ambient controller.

Guide specifications — RGF

Note about this specification:

This specification is in the "Masterformat" as published by the Construction Specification Institute. Please feel free to copy this specification directly into your building spec.

Gas Heat/Electric Cooling Packaged Rooftop

HVAC Guide Specifications

Size Range: **17.5 to 27.5 Nominal Tons**

Model Number: **RGF210-336**

Part 1 — (23 06 80) Schedules for Decentralized HVAC Equipment

- 1.01 (23 06 80.13) Decentralized Unitary HVAC Equipment Schedule
- A. (23 06 80.13.A.) Rooftop Unit (RTU) Schedule:
Schedule is per the project specification requirements.

Part 2 — (23 07 16) HVAC Equipment Insulation

- 2.01 (23 07 16.13) Decentralized, Rooftop Units:
- A. (23 07 16.13.A.) Evaporator Fan Compartment:
1. Interior cabinet surfaces shall be insulated with a minimum 1/2 in. thick, minimum 1 1/2 lb density, flexible fiberglass insulation bonded with a phenolic binder, neoprene coated on the air side.
 2. Insulation and adhesive shall meet NFPA 90A requirements for flame spread and smoke generation.
- B. (23 07 16.13.B.) Gas Heat Compartment:
1. Aluminum foil-faced fiberglass insulation shall be used.
 2. Insulation and adhesive shall meet NFPA 90A requirements for flame spread and smoke generation.

Part 3 — (23 09 13) Instrumentation and Control Devices for HVAC

- 3.01 (23 09 13.23) Sensors and Transmitters
- A. (23 09 13.23.A.) Thermostats:
1. Thermostat must:
 - a. energize both "W" and "G" when calling for heat.
 - b. have capability to energize 1 or 2 stages of cooling, and 2 different stages of heating.
 - c. include capability for occupancy scheduling.

Part 4 — (23 09 33) Electric and Electronic Control System for HVAC

- 4.01 (23 09 33.13) Decentralized, Rooftop Units:
- A. (23 09 33.13.A.) General:
1. Shall be complete with self-contained low-voltage control circuit protected by a resettable circuit breaker on the 24-v transformer side. Transformer shall have 75VA capability.
 2. Shall utilize color-coded wiring.

3. Shall include a Unit Control Board to conveniently and safely provide connection points for vital control functions such as: smoke detectors, phase monitor, gas controller, economizer, thermostat, and low and high pressure switches. Controller shall also provide an intuitive means to adjust the indoor fan speed through a simple switch and pot adjustment design.
 4. The heat exchanger shall be controlled by an integrated gas controller (IGC) microprocessor. See gas heat section of this specification.
 5. Unit shall include a minimum of one 8-pin screw terminal connection board for connection of control wiring.
- B. (23 09 33.13.B.) Safeties:
1. Compressor over-temperature, over-current. High internal pressure differential.
 2. Low Pressure Switch.
 - a. Low pressure switch shall use different color wire than the high pressure switch. The purpose is to assist the installer and service technician to correctly wire and or troubleshoot the rooftop unit.
 3. High Pressure Switch.
 - a. High pressure switch shall use different color wire than the low pressure switch. The purpose is to assist the installer and service technician to correctly wire and or troubleshoot the rooftop unit.
 4. Mixed Air Auto Reset Temperature Switch.
 - a. All cooling units contain a low return air (or mixed air - depending on unit configuration) temperature switch for compressor protection. The switch prevents compressor operation at mixed air temperatures below 60°F (16°C) to ensure long term reliability but allows continued fan and economizer operation (if installed). The switch will automatically reset when the return/mixed air temperature warms above 65°F (18°C) and will allow compressor operation to continue.
 5. Automatic Reset, Motor Thermal Overload Protector.
 6. Heating section shall be provided with the following minimum protections:
 - a. High temperature limit switches.
 - b. Induced draft motor speed sensor.
 - c. Flame rollout switch.
 - d. Flame proving controls.
 7. A2L Refrigerant Leak Dissipation System (Electromechanical)
 - a. Leak dissipation system shall consist of control board and A2L sensor certified to UL 60335-2-40.

Guide specifications — RGF (cont)

- b. System shall be designed for the life of the unit.
 - c. Dissipation system shall be automatic, ship pre-wired, and require no additional field connections to thermostat to function.
 - d. Refrigerant leak sensor shall be installed in UL certified location and orientation. Sensor shall be self-correcting and resettable. Single use refrigerant leak sensor shall not be permitted.
 - e. Factory installed dissipation controller shall use onboard microprocessor and include:
 - 1) Automatic reset after a dissipation event has occurred
 - 2) Onboard LED with flash code to indicate current unit status and hardware failures
 - 3) Depressible “Test” button to allow for a system test and recall/reset of leak detection history
 - 4) 24V dry contact alarm terminal to allow for external notification of leak detection
 - f. Dissipation control board shall be accessible via normal maintenance locations and LED shall be visible.
 - g. Dissipation system shall “Fail Safe” per UL requirements.
 - h. Dissipation shall allow smoke and building fire systems to override in case of event.
- 2. Factory assembled, single-piece heating and cooling rooftop unit. Contained within the unit enclosure shall be all factory wiring, piping, controls, and special features required prior to field start-up.
 - 3. Unit shall use R-454B refrigerant.
 - 4. Unit shall be installed in accordance with the manufacturer’s instructions.
 - 5. Unit must be selected and installed in compliance with local, state, and federal codes.
- B. (23 81 19.13.B.) Quality Assurance:
- 1. Unit meets DOE and ASHRAE 90.1 minimum efficiency requirements.
 - 2. Unit shall be rated in accordance with AHRI Standards 340/360.
 - 3. Unit shall be designed to conform to ASHRAE 15.
 - 4. Unit shall be UL-tested and certified in accordance with ANSI Z21.47 Standards and UL-listed and certified under Canadian standards as a total package for safety requirements.
 - 5. Insulation and adhesive shall meet NFPA 90A requirements for flame spread and smoke generation.
 - 6. Unit casing shall be capable of withstanding 500 hour salt spray exposure per ASTM B117 (scribed specimen).
 - 7. Unit shall be designed in accordance with ISO 9001, and shall be manufactured in a facility registered by ISO 9001:2015.
 - 8. Roof curb shall be designed to conform to NRCA Standards.
 - 9. Unit shall be subjected to a completely automated run test on the assembly line. The data for each unit will be stored at the factory, and must be available upon request.
 - 10. Unit shall be designed in accordance with UL Standard 600335-1 and 60335-2-40, to withstand rain. Unit shall be IPX4 rated.
 - 11. Unit shall be constructed to prevent intrusion of snow and tested to prevent snow intrusion into the control box up to 40 mph.
 - 12. Unit shake tested to assurance level 1, ASTM D4169 to ensure shipping reliability.

Part 5 — (23 09 93) Sequence of Operation for HVAC Controls

5.01 (23 09 93.13) Decentralized, Rooftop Units:

- A. (23 09 93.13.A.) INSERT SEQUENCE OF OPERATION

Part 6 — (23 40 13) Panel Air Filters

6.01 (23 40 13.13) Decentralized, Rooftop Units:

- A. (23 40 13.13.A.) Standard Filter Section:
 - 1. Shall consist of factory installed, low velocity, disposable 2 in. thick fiberglass filters of commercially available sizes.
 - 2. Unit shall use only one filter size. Multiple sizes are not acceptable.
 - 3. Filters shall be accessible through an access panel with “no-tool” removal as described in the unit cabinet section of this specification (23 81 19.13.G).

Part 7 — (23 81 19) Self-Contained Air Conditioners

7.01 (23 81 19.13) Small-Capacity Self-Contained Air Conditioners:

- A. (23 81 19.13.A.) General:
 - 1. Outdoor, rooftop mounted, electrically controlled, heating and cooling unit utilizing a fully hermetic scroll compressor(s) for cooling duty and gas combustion for heating duty.

- C. (23 81 19.13.C.) Delivery, Storage, and Handling:
 - 1. Unit shall be stored and handled per manufacturer’s recommendations.
 - 2. Lifted by crane requires either shipping top panel or spreader bars.
 - 3. Unit shall only be stored or positioned in the upright position.
- D. (23 81 19.13.D.) Project Conditions:
 - 1. As specified in the contract.

Guide specifications — RGF (cont)

E. (23 81 19.13.E.) Operating Characteristics:

1. Unit shall be capable of starting and running at 115°F (46°C) ambient outdoor temperature meeting maximum load criteria of AHRI Standard 340/360 at ±10% voltage.
2. Compressor with standard controls shall be capable of operation down to 40°F (4°C) ambient outdoor temperatures.
3. Unit shall discharge supply air vertically or horizontally as shown on contract drawings.
4. Unit shall be factory configured for vertical supply and return configurations or horizontal supply and return configurations. Unit shall not require field conversion.

F. (23 81 19.13.F.) Electrical Requirements:

1. Main power supply voltage, phase, and frequency must match those required by the manufacturer.

G. (23 81 19.13.G.) Unit Cabinet:

1. Unit cabinet shall be constructed of galvanized steel, and shall be bonderized and coated with a prepainted baked enamel finish on all externally exposed surfaces.
2. Unit cabinet exterior paint shall be: film thickness, (dry) 0.003 inches minimum, gloss (per ASTM D523, 60°F/16°C): 60, Hardness: H-2H Pencil hardness.
3. Evaporator fan compartment interior cabinet insulation shall conform to AHRI Standards 340/360 minimum exterior sweat criteria. Interior surfaces shall be insulated with a minimum 1/2 in. thick, 1 lb density, flexible fiberglass insulation, neoprene coated on the air side. Aluminum foil-faced fiberglass insulation shall be used in the heat compartment.
4. Base of unit shall have a minimum of 4 locations for thru-the-base gas and electrical connections (factory-installed, standard).
5. Base Rail:
 - a. Unit shall have base rails on a minimum of 2 sides.
 - b. Holes shall be provided in the base rails for rigging shackles to facilitate maneuvering and overhead rigging.
 - c. Holes shall be provided in the base rail for moving the rooftop by fork truck.
 - d. Base rail shall be a minimum of 16 gauge thickness.
6. Condensate Pan and Connections:
 - a. Shall be a sloped condensate drain pan made of a corrosion resistant material.
 - b. Shall comply with ASHRAE Standard 62.
 - c. Shall use a 3/4 in. 14 NPT drain connection, possible either through the bottom or side of the drain pan. Connection shall be made per manufacturer's recommendations.

7. Top Panel:

- a. Shall be a multi-top panel linked with water-tight flanges and locking systems.

8. Gas Connections:

- a. All gas piping connecting to unit gas valve shall enter the unit cabinet at a single location on side of unit (horizontal plane).
- b. Thru-the-base capability.
 - 1) Standard unit shall have thru-the-base gas-line location using a raised, embossed portion of the unit basepan standard. No additional accessory necessary.
 - 2) No basepan penetration, other than those authorized by the manufacturer, is permitted.

9. Electrical Connections:

- a. All unit power wiring shall enter unit cabinet at a single, factory prepared, knockout location.
- b. Thru-the-base capability.
 - 1) Thru-the-base provisions/connections are available as standard with every unit. When bottom connections are required, field furnished couplings are require.
 - 2) No basepan penetration, other than those authorized by the manufacturer, is permitted.

10. Component Access Panels (standard):

- a. Cabinet panels shall be easily removable for servicing.
- b. Unit shall have one factory installed, tool-less, filter access panel.
- c. Panels covering control box, indoor fan, indoor fan motor, gas components (where applicable), and compressors shall have molded composite handles.
- d. Handles shall be UV modified, composite. They shall be permanently attached, and recessed into the panel.
- e. Screws on the vertical portion of all removable access panel shall engage into heat resistant, molded composite collars.
- f. Collars shall be removable and easily replaceable using manufacturer recommended parts.

H. (23 81 19.13.H.) Gas Heat:

1. General:

- a. Heat exchanger shall be an induced draft design. Positive pressure heat exchanger designs shall not be allowed.
- b. Shall incorporate a direct-spark ignition system and redundant main gas valve.

Guide specifications — RGF (cont)

- c. Gas supply pressure at the inlet to the roof-top unit gas valve must match that required by the manufacturer.
 2. The heat exchanger shall be controlled by an integrated gas controller (IGC) microprocessor.
 - a. IGC board shall notify users of fault using an LED (light-emitting diode).
 - b. The LED shall be visible without removing the control box access panel.
 - c. IGC board shall contain algorithms that modify evaporator fan operation to prevent future cycling on high temperature limit switch.
 - d. Unit shall be equipped with anti-cycle protection with one short cycle on unit flame rollout switch or 4 continuous short cycles on the high temperature limit switch. Fault indication shall be made using an LED.
 3. Standard Heat Exchanger Construction:
 - a. Heat exchanger shall be of the tubular-section type constructed of a minimum of 20 gauge steel coated with a nominal 1.2 mil aluminum-silicone alloy for corrosion resistance.
 - b. Burners shall be of the in-shot type constructed of aluminum-coated steel.
 - c. Burners shall incorporate orifices for rated heat output up to 2000 ft (610 m) elevation. Additional accessory kits may be required for applications above 2000 ft (610 m) elevation, depending on local gas supply conditions.
 - d. Each heat exchanger tube shall contain multiple dimples for increased heating effectiveness.
 4. Optional Stainless Steel Heat Exchanger Construction:
 - a. Use energy saving, direct-spark ignition system.
 - b. Use a redundant main gas valve.
 - c. Burners shall be of the in-shot type constructed of aluminum-coated steel.
 - d. All gas piping shall enter the unit cabinet at a single location on side of unit (horizontal plane).
 - e. The optional stainless steel heat exchanger shall be of the tubular-section type, constructed of a minimum of 20 gauge type 409 stainless steel.
 - f. Type 409 stainless steel shall be used in heat exchanger tubes and vestibule plate.
 - g. Complete stainless steel heat exchanger allows for greater application flexibility.
 5. Induced Draft Combustion Motor and Blower:
 - a. Shall be a direct-drive, single inlet, forward-curved centrifugal type.
 - b. Shall be made from steel with a corrosion resistant finish.
 - c. Shall have permanently lubricated sealed bearings.
 - d. Shall have inherent thermal overload protection.
 - e. Shall have an automatic reset feature.
- I. (23 81 19.13.I.) Coils:
 1. Standard Aluminum Fin-Copper Tube Coils:
 - a. Standard evaporator and condenser coils shall have aluminum lanced plate fins mechanically bonded to seamless internally grooved copper tubes with all joints brazed.
 - b. Evaporator coils shall be leak tested to 150 psig, pressure tested to 450 psig, and qualified to UL 1995 burst test at 1775 psig.
 - c. Condenser coils shall be leak tested to 150 psig, pressure tested to 650 psig, and qualified to UL 60335-2-40 burst test at 1980 psig.
 2. Optional Pre-coated Aluminum-Fin Condenser Coils:
 - a. Shall have a durable epoxy-phenolic coating to provide protection in mildly corrosive coastal environments.
 - b. Coating shall be applied to the aluminum fin stock prior to the fin stamping process to create an inert barrier between the aluminum fin and copper tube.
 - c. Epoxy-phenolic barrier shall minimize galvanic action between dissimilar metals.
 - d. Corrosion durability of fin stock shall be confirmed through testing to be no less than 1000 hours salt spray per ASTM B117.
 - e. Corrosion durability of fin stock shall be confirmed through testing to have no visible corrosion after 48 hour immersion in a room temperature solution of 5% salt, 1% acetic acid.
 - f. Fin stock coating shall pass 2000 hours of the following: one week exposure in the prohesion chamber followed by one week of accelerated ultraviolet light testing. Prohesion chamber: the solution shall contain 3.5% sodium chloride and 0.35% ammonium sulfate. The exposure cycle is one hour of salt fog application at ambient followed by one hour drying at 95°F (35°C).
 3. Optional Copper-fin Evaporator and Condenser Coils:
 - a. Shall be constructed of copper fins mechanically bonded to copper tubes and copper tube sheets.
 - b. Galvanized steel tube sheets shall not be acceptable.

Guide specifications — RGF (cont)

- c. A polymer strip shall prevent coil assembly from contacting the sheet metal coil pan to minimize potential for galvanic corrosion between coil and pan.
- 4. Optional E-coated Aluminum-Fin Evaporator and Condenser Coils:
 - a. Shall have a flexible epoxy polymer coating uniformly applied to all coil surface areas without material bridging between fins.
 - b. Coating process shall ensure complete coil encapsulation of tubes, fins and headers.
 - c. Color shall be high gloss black with gloss per ASTM D523-89.
 - d. Uniform dry film thickness from 0.8 to 1.2 mil on all surface areas including fin edges.
 - e. Superior hardness characteristics of 2H per ASTM D3363- and cross-hatch adhesion of 4B-5B per ASTM D3359.
 - f. Impact resistance shall be up to 160 in. lb (ASTM D2794).
 - g. Humidity and water immersion resistance shall be up to minimum 1000 and 250 hours respectively (ASTM D2247 and ASTM D870).
 - h. Corrosion durability shall be confirmed through testing to be no less than 1000 hours salt spray per ASTM B117.
- J. (23 81 19.13.J.) Refrigerant Components:
 - 1. Refrigerant circuit shall include the following control, safety, and maintenance features:
 - a. Thermostatic Expansion Valve (TXV) shall help provide optimum performance across the entire operating range. Shall contain removable power element to allow change out of power element and bulb without removing the valve body.
 - b. Refrigerant filter drier — Solid core design with pre and post filter service gauge connections for filter diagnostics and maintenance.
 - c. Service gauge connections on suction and discharge lines.
 - d. Pressure gauge access through a specially designed access port in the unit.
 - 2. There shall be gauge line access port in the skin of the rooftop, covered by a black, removable plug.
 - a. The plug shall be easy to remove and replace.
 - b. When the plug is removed, the gauge access port shall enable maintenance personnel to route their pressure gauge lines.
 - c. This gauge access port shall facilitate correct and accurate condenser pressure readings by enabling the reading with the compressor access panel on.
- d. The plug shall be made of leak proof, UV-resistant, composite material.
- 3. Compressors:
 - a. Unit shall use tandem scroll compressor assembly on single independent refrigeration circuit with two stages of cooling for efficient comfort cooling operation.
 - b. Evaporator coils shall be a full active design to help better control comfort latent removal and minimize unconditioned bypass air.
 - c. Compressor motors shall be cooled by refrigerant gas passing through motor windings.
 - d. Compressors shall be internally protected from high discharge temperature conditions.
 - e. Compressors shall be protected from an over-temperature and over-amperage conditions by an internal, motor overload device.
 - f. Compressor shall be factory-mounted on rubber grommets.
 - g. Compressor motors shall have internal line break thermal, current overload and high pressure differential protection.
 - h. Crankcase heaters shall not be required for normal operating range, unless required by the manufacturer due to refrigerant charge limits.
- K. (23 81 19.13.K.) Filter Section:
 - 1. Filters access is specified in the unit cabinet section of this specification.
 - 2. Filters shall be held in place by a pivoting filter tray, facilitating easy removal and installation.
 - 3. Shall consist of factory installed, low velocity, throw-away 2 in. thick fiberglass filters.
 - 4. Filters shall be standard, commercially available sizes.
 - 5. Only one size filter per unit is allowed.
- L. (23 81 19.13.L.) Evaporator Fan and Motor with X-Vane™ Fan Technology:
 - 1. Direct Drive Evaporator Fan Motor:
 - a. Shall be a ECM motor design.
 - b. Shall be direct drive design for all static options.
 - c. Shall have permanently lubricated bearings.
 - d. Shall have inherent automatic-reset thermal overload protection.
 - e. Shall have slow ramp up to speed capabilities.
 - f. Shall require no fan/motor belts for operation, adjustments and or initial fan speed set up.
 - g. Fan DC voltage set up on Unit Control Board shall eliminate the need of removal

Guide specifications — RGF (cont)

of blower access door, required on conventional belt drive systems.

- h. Shall be internally protected from electrical phase reversal.

2. Evaporator Fan:

- a. Shall be easily set with dedicated selection switch and adjustment pot on unit control board.
- b. Shall provide 2 stage cooling capacity control, the indoor fan speed is automatically controlled to meet the code-compliant low fan speed and 100% at full fan speed operation.
- c. Blower fans shall be a Vane Axial fan design with fan assembly secured directly to ECM motor. Additional shafts, belts, pulleys/sheaves, and bearing blocks to drive fan shall not be permitted or necessary.
- d. Additional variable frequency drive to control fan motor speed shall not be permitted or necessary. All speed control electronics must be onboard fan motor assembly.
- e. Shall be constructed of a cast aluminum stator and high impact composite material on rotor and air inlet casing.
- f. Shall be a patented / pending design with a corrosion resistant material.
- g. Fan assembly design shall be integrated to fan deck, dynamically balanced, and require no additional vibration isolation for normal operation.
- h. Shall have slow ramp up to speed capabilities to help reduce sound and comfort issues typically associated with single speed belt drive systems.
- i. Units shall contain 2 separate vane axial fan assemblies.
- j. Shall be a slide out design with removal of a few support brackets.

- 3. Shall include an easily accessible Unit Control Board to conveniently and safely provide connection points for vital control functions such as: smoke detectors, phase monitor, gas controller, economizer, thermostat, and low and high pressure switches. Controller shall also provide an intuitive means to adjust the indoor fan speed through a simple switch and pot adjustment design.

M. (23 81 19.13.M.) Condenser Fans and Motors:

1. Condenser Fan Motors:

- a. Shall be a totally enclosed motor.
- b. Shall use permanently lubricated bearings.
- c. Shall have inherent thermal overload protection with an automatic reset feature.
- d. Shall use a shaft-down design on all sizes.

2. Condenser Fans:

- a. Shall be a direct-driven propeller type fan.

- b. Shall have galvalum blades riveted to steel spider that have corrosion-resistant properties and shall be dynamically balanced.

N. (23 81 19.13.N.) Special Features Options and Accessories:

1. Integrated EconomizerONE Low Leak Rate Models.

- a. Integrated, gear driven opposing modulating blade design type capable of simultaneous economizer and compressor operation.
- b. Independent modules for vertical or horizontal return configuration shall be available. Vertical return modules shall be available as a factory installed option.
- c. Damper blades shall be galvanized steel with composite gears. Plastic or composite blades on intake or return shall not be acceptable.
- d. Shall include all hardware and controls to provide free cooling with outdoor air when temperature and/or humidity are below set points.
- e. Shall be equipped with gear driven dampers for both the outdoor ventilation air and the return air for positive air stream control.
- f. Low leak rate shall be equipped with dampers not to exceed 2% leakage at 1 in. wg pressure differential.
- g. Economizer controller on EconomizerONE models shall be Siemens POL224 that provides:
 - 1) Combined minimum and DCV maximum damper position potentiometers with compressor staging relay.
 - 2) Optional configuration via WLAN stick and Siemens Climatix™¹ smartphone app for easy setup.
 - 3) Functions with solid-state analog enthalpy or dry bulb changeover control sensing.
 - 4) LED indication for free cooling, sensor, and damper operation.
 - 5) One-line LCD interface screen for setup, configuration and troubleshooting.
 - 6) On-board Fault Detection and Diagnostics (FDD) that senses and alerts when the economizer is not operating properly, per California Title 24, ASHRAE 90.1 and IECC®¹.
 - 7) Sensor failure loss of communication identification.
 - 8) Capabilities for use with multiple-speed or single speed indoor fan systems.

1. Third-party trademarks and logos are the property of their respective owners.

Guide specifications — RGF (cont)

- 9) Digital sensors: Dry bulb and Enthalpy.
 - h. Shall be capable of introducing up to 100% outdoor air.
 - i. Shall be equipped with a barometric relief damper capable of relieving up to 100% return air and contain seals that meet ASHRAE 90.1 requirements.
 - j. Shall be designed to close damper(s) during loss-of-power situations with spring return built into motor.
 - k. Dry bulb outdoor air temperature sensor shall be provided as standard. Enthalpy sensor is also available on factory-installed economizers only. Outdoor air sensor set-point shall be adjustable and shall range from 40°F to 100°F (4°C to 38°C). Additional sensor options shall be available as accessories.
 - l. The economizer controller shall also provide control of an accessory power exhaust unit function. Factory set at 100%, with a range of 0% to 100%.
 - m. The economizer shall maintain minimum airflow into the building during occupied period and provide design ventilation rate for full occupancy.
 - n. Dampers shall be completely closed when the unit is in the unoccupied mode.
 - o. Economizer controller shall accept a 0 to 10 vdc CO₂ sensor input for IAQ/DCV control. In this mode, dampers shall modulate the outdoor air damper to provide ventilation based on the sensor input.
 - p. Compressor lockout temperature on POL224 control is adjustable from -45°F to 80°F (-43°C to 26°C), set at a factory default of 32°F (0°C).
 - q. Actuator shall be direct coupled to economizer gear. No linkage arms or control rods shall be acceptable.
 - r. Contain LED indication for free cooling, sensor, and damper operation.
2. Integrated EconomizerONE Ultra Low Leak Rate Models.
- a. Integrated, gear driven opposing modulating blade design type capable of simultaneous economizer and compressor operation.
 - b. Independent modules for vertical or horizontal return configuration shall be available. Vertical return modules shall be available as a factory installed option.
 - c. Damper blades shall be galvanized steel with composite gears. Plastic or composite blades on intake or return shall not be acceptable.
 - d. Shall include all hardware and controls to provide free cooling with outdoor air when temperature and/or humidity are below setpoints.
 - e. Shall be equipped with gear driven dampers for both the outdoor ventilation air and the return air for positive air stream control.
 - f. Ultra Low Leak design meets California Title 24 section 140.4 and ASHRAE 90.1 requirements for 4 cfm per sq ft on the outside air dampers and 10 cfm per sq ft on the return dampers.
 - g. Economizer controller on EconomizerONE models shall be the Siemens POL224 that provides:
 - 1) One-line LCD interface screen for setup, configuration and troubleshooting.
 - 2) Optional configuration via WLAN stick and Siemens Climatix™ smartphone app for easy setup.
 - 3) On-board Fault Detection and Diagnostics (FDD) that senses and alerts when the economizer is not operating properly, per California Title 24, ASHRAE 90.1 and IECC.
 - 4) Sensor failure loss of communication identification.
 - 5) Capabilities for use with multiple-speed indoor fan systems.
 - 6) Digital sensors: Dry bulb and Enthalpy.
 - h. Shall be capable of introducing up to 100% outdoor air.
 - i. Shall be equipped with a barometric relief damper capable of relieving up to 100% return air and contain seals that meet ASHRAE 90.1 requirements.
 - j. Shall be designed to close damper(s) during loss-of-power situations with spring return built into motor.
 - k. Dry bulb outdoor air temperature sensor shall be provided as standard. Enthalpy sensor is also available on factory-installed economizers only. Outdoor air sensor set-point shall be adjustable and shall range from 40°F to 100°F (4°C to 38°C). Additional sensor options shall be available as accessories.
 - l. The economizer controller shall also provide control of an accessory power exhaust unit function. Factory set at 100%, with a range of 0% to 100%.
 - m. The economizer shall maintain minimum airflow into the building during occupied period and provide design ventilation rate for full occupancy.
 - n. Dampers shall be completely closed when the unit is in the unoccupied mode.

Guide specifications — RGF (cont)

- o. Economizer controller shall accept a 0 to 10 vdc CO₂ sensor input for IAQ/DCV control. In this mode, dampers shall modulate the outdoor air damper to provide ventilation based on the sensor input.
 - p. Compressor lockout temperature on POL224 control is adjustable from -45°F to 80°F (-43°C to 26°C), set at a factory default of 32°F (0°C).
 - q. Actuator shall be direct coupled to economizer gear. No linkage arms or control rods shall be acceptable.
 - r. Contains LED indication for free cooling, sensor, and damper operation.
3. Wi-Fi/WLAN Stick for EconomizerONE POL224 (field-installed):
This item allows use of the Siemens Climatix™ mobile application.
4. Two-Position Damper (Field-installed only):
- a. Damper shall be a Two-Position Damper. Damper travel shall be from the full closed position to the field adjustable %-open setpoint.
 - b. Damper shall include adjustable damper travel from 25% to 100% (full open).
 - c. Damper shall include single or dual blade, gear driven dampers and actuator motor.
 - d. Actuator shall be direct coupled to damper gear. No linkage arms or control rods shall be acceptable.
 - e. Damper will admit up to 100% outdoor air for applicable rooftop units.
 - f. Damper shall close upon indoor (evaporator) fan shutoff and/or loss of power.
 - g. The damper actuator shall plug into the rooftop unit's wiring harness plug. No hard wiring shall be required.
 - h. Outside air hood shall include aluminum water entrainment filter.
5. Manual Damper (Field-installed only):
- a. Manual damper package shall consist of damper, air inlet screen, and rain hood which can be preset to admit up to 25 or 50% outdoor air for year round ventilation.
6. Hot Gas Re-Heat Dehumidification System:
The Hot Gas Re-Heat Dehumidification System shall be factory installed and shall provide greater dehumidification of the occupied space by 2 modes of dehumidification operations in addition to its normal design cooling mode:
- a. Subcooling mode further sub cools the hot liquid refrigerant leaving the condenser coil when both temperature and humidity in the space are not satisfied.
 - b. Hot gas reheat mode shall mix a portion of the hot gas from the discharge of the compressor with the hot liquid refrigerant leaving the condenser coil to create a 2-phase heat transfer in the system, resulting in a neutral leaving air temperature when only humidity in the space is not satisfied.
- c. Includes low ambient controller.
7. Low Ambient Control Package:
- a. Controller shall control coil head pressure by condenser fan speed modulation or condenser fan cycling and wind baffles.
 - b. Shall consist of solid-state control and condenser coil temperature sensor to maintain condensing temperature between 90°F (32°C) and 110°F (43°C) at outdoor ambient temperatures down to -20°F (-29°C). For full low ambient control range Winter Start kit is required.
8. Propane Gas Conversion Kit:
- a. Package shall contain all the necessary hardware and instructions to convert a standard natural gas unit for use with liquefied propane, up to 2000 ft (610 m) elevation.
 - b. Additional accessory kits may be required for applications above 2000 ft (610 m) elevation.
9. Flue Shield:
Flue shield shall provide protection from the hot sides of the gas flue hood.
10. Condenser Coil Hail Guard Assembly (Factory or field installed):
- a. Shall protect against hail and additional coil damage.
 - b. Shall be louvered type.
11. Unit-Mounted, Non-Fused Disconnect Switch:
- a. Available on 17.5 to 27.5 ton units with FLA of 100 amps (460/575V) or 200 amps or less (208/230V).
 - b. Switch shall be factory installed, internally mounted.
 - c. National Electric Code (NEC) and UL approved non-fused switch shall provide unit power shut-off.
 - d. Shall be accessible from outside the unit.
 - e. Shall provide local shutdown and lockout capability.
 - f. Sized **only** for the unit as ordered from the factory. Does not accommodate field-installed devices.
12. Convenience Outlet:
- a. Factory-Installed Powered Convenience Outlet.
 - 1) Outlet shall be powered from main line power to the rooftop unit.
 - 2) Outlet shall be powered from line side or load side of disconnect by installing

Guide specifications — RGF (cont)

- contractor, as required by code. If outlet is powered from load side of disconnect, unit electrical ratings shall be UL certified and rated for additional outlet amperage.
- 3) Outlet shall be factory-installed and internally mounted with easily accessible 115-v female receptacle.
 - 4) Outlet shall include 15 amp GFI receptacles with independent fuse protection.
 - 5) Voltage required to operate convenience outlet shall be provided by a factory installed step-down transformer.
 - 6) Outlet shall be accessible from outside the unit.
 - 7) Outlet shall include a field installed "Wet in Use" cover.
- b. Factory-Installed Non-Powered Convenience Outlet.
- 1) Outlet shall be powered from a separate 115/120v power source.
 - 2) A transformer shall not be included.
 - 3) Outlet shall be factory-installed and internally mounted with easily accessible 115-v female receptacle.
 - 4) Outlet shall include 15 amp GFI receptacles with independent fuse protection.
 - 5) Outlet shall be accessible from outside the unit.
 - 6) Outlet shall include a field installed "Wet in Use" cover.
- c. Field-Installed Non-Powered Convenience Outlet.
- 1) Outlet shall be powered from a separate 115/120v power source.
 - 2) A transformer shall not be included.
 - 3) Outlet shall be field-installed and internally mounted with easily accessible 115-v female receptacle.
 - 4) Outlet shall include 20 amp GFI receptacles. This kit provides a flexible installation method which allows code compliance for height requirements of the GFCI outlet from the finished roof surface as well as the capability to relocate the outlet to a more convenient location.
 - 5) Outlet shall be accessible from outside the unit.
 - 6) Outlet shall include a field installed "Wet in Use" cover.
13. Flue Discharge Deflector:
- a. Flue discharge deflector shall direct unit exhaust vertically instead of horizontally.
 - b. Deflector shall be defined as a "natural draft" device by the National Fuel and Gas (NFG) code.
14. Thru-the-Base Connectors:
- a. Kits shall provide connectors to permit gas and electrical connections to be brought to the unit through the unit basepan.
 - b. Minimum of 4 connection locations per unit.
15. Centrifugal Fan Power Exhaust:
- a. Power exhaust shall be used in conjunction with an integrated economizer.
 - b. Horizontal power exhaust shall be mounted in return ductwork.
 - c. Power exhaust shall be controlled by economizer controller operation. Exhaust fans shall be energized when dampers open past the 0 to 100% adjustable setpoint on the economizer control.
16. Roof Curbs (Vertical):
- a. Full perimeter roof curb with exhaust capability providing separate air streams for energy recovery from the exhaust air without supply air contamination.
 - b. Formed galvanized steel with wood nailer strip and shall be capable of supporting entire unit weight.
 - c. Permits installation and securing of ductwork to curb prior to mounting unit on the curb.
17. High Altitude Gas Conversion Kit:
- Package shall contain all the necessary hardware and instructions to convert a standard natural gas unit to operate from 2000 to 7000 ft (610 to 2134 m) elevation with natural gas or from 0 to 7000 ft (0 to 2134 m) elevation with liquefied propane.
18. Outdoor Air Enthalpy Sensor:
- The outdoor air enthalpy sensor shall be used to provide single enthalpy control. When used in conjunction with a return air enthalpy sensor, the unit will provide differential enthalpy control. The sensor allows the unit to determine if outside air is suitable for free cooling.
19. Return Air Enthalpy Sensor:
- The return air enthalpy sensor shall be used in conjunction with an outdoor air enthalpy sensor to provide differential enthalpy control.
20. Indoor Air Quality (CO₂) Sensor:
- a. Shall be able to provide demand ventilation indoor air quality (IAQ) control.
 - b. The IAQ sensor shall be available in duct mount, wall mount, or wall mount with LED display. The setpoint shall have adjustment capability.

Guide specifications — RGF (cont)

21. Smoke Detectors:
 - a. Shall be a 4-Wire Controller and Detector.
 - b. Shall be environmental compensated with differential sensing for reliable, stable, and drift-free sensitivity.
 - c. Shall use magnet-activated test/reset sensor switches.
 - d. Shall have tool-less connection terminal access.
 - e. Shall have a recessed momentary switch for testing and resetting the detector.
 - f. Controller shall include:
 - 1) One set of normally open alarm initiation contacts for connection to an initiating device circuit on a fire alarm control panel.
 - 2) Two Form-C auxiliary alarm relays for interface with rooftop unit or other equipment.
 - 3) One Form-C supervision (trouble) relay to control the operation of the Trouble LED on a remote test/reset station.
 - 4) Capable of direct connection to 2 individual detector modules.
 - 5) Can be wired to up to 14 other duct smoke detectors for multiple fan shut-down applications.
22. Winter Start Kit:
 - a. Shall contain a bypass device around the low pressure switch.
 - b. Shall be required when mechanical cooling is required down to 40°F (4°C).
 - c. Shall not be required to operate on an economizer when below an outdoor ambient of 40°F (4°C).
23. Time Guard:
 - a. Shall prevent compressor short-cycling by providing a 5-minute delay (± 2 minutes) before restarting a compressor after shut-down for any reason.
 - b. One device shall be required per compressor.
24. Hinged Access Panels:
 - a. Shall provide easy access through integrated quarter turn latches.
 - b. Shall be on major panels of: filter, control box, fan motor, and compressor.
25. Condensate Overflow Switch:

The sensor and related controller monitors the condensate level in the drain pan and shuts down compression operation when overflow conditions occur. It includes:

 - a. Indicator light — solid red (more than 10 seconds on water contact — compressors disabled), blinking red (sensor disconnected).
 - b. 10 second delay to break — eliminates nuisance trips from splashing or eaves in pan (sensor needs 10 seconds of constant water contact before tripping).
 - c. Disables the compressor(s) operation when condensate plug is detected, but still allows fans to run for Economizer.
26. 4 in. Return Air Rack (Field Installed Only);
 - a. Accessory kit is designed to hold 4 in. MERV-8 or MERV-13 filters. Filters not included in kit.
27. Phase Monitor Control:
 - a. Shall monitor the sequence of 3-phase electrical system to provide a phase reversal protection.
 - b. Shall monitor the 3-phase voltage inputs to provide a phase loss protection for the 3-phase device.
 - c. Will work on either a Delta or Wye power connection.
28. Horn/Strobe Annunciator:
 - a. Provides an audible/visual signaling device for use with factory-installed option or field installed accessory smoke detectors.
 - b. Requires installation of a field-supplied 24-v transformer suitable for 4.2 VA (AC) or 3.0 VA (DC) per horn/strobe accessory.
 - c. Requires field-supplied electrical box, North American 1-gang box, 2 in. x 4 in. (51 mm x 102 mm).
 - d. Shall have a clear colored lens.
29. High Short Circuit Current Rating (SCCR) Protection:
 - a. Factory-installed option provides high short circuit current protection to each compressor, plus all indoor and outdoor fan motors of 60 kA for 208/230-3-60 units and 65 kA for 460-3-60 units against high potential fault current situations. (Standard unit comes with 5 kA rating.)
 - b. This option is not available with factory installed Hot Gas Re-Heat system, Powered Convenience Outlet, Non-Fused Disconnect, Low Ambient controls, Phase Loss monitor/protection and 575 Volt models.

Guide specifications — RAF

Note about this specification:

This specification is in the "Masterformat" as published by the Construction Specification Institute. Please feel free to copy this specification directly into your building spec.

Electric Cooling Packaged Rooftop

HVAC Guide Specifications

Size Range: **17.5 to 27.5 Nominal Tons**

Model Number: **RAF210-336**

Part 1 — (23 06 80) Schedules for Decentralized HVAC Equipment

1.01 (23 06 80.13) Decentralized Unitary HVAC Equipment Schedule:

- A. (23 06 80.13.A.) Rooftop Unit (RTU) Schedule:
Schedule is per the project specification requirements.

Part 2 — (23 07 16) HVAC Equipment Insulation

2.01 (23 07 16.13) Decentralized, Rooftop Units:

- A. (23 07 16.13.A.) Evaporator Fan Compartment:
1. Interior cabinet surfaces shall be insulated with a minimum 1/2 in. thick, minimum 1 1/2 lb density, flexible fiberglass insulation bonded with a phenolic binder, neoprene coated on the air side.
 2. Insulation and adhesive shall meet NFPA 90A requirements for flame spread and smoke generation.
- B. (23 07 16.13.B.) Electric Heat Compartment:
1. Aluminum foil-faced fiberglass insulation shall be used.
 2. Insulation and adhesive shall meet NFPA 90A requirements for flame spread and smoke generation.

Part 3 — (23 09 13) Instrumentation and Control Devices for HVAC

3.01 (23 09 13.23) Sensors and Transmitters:

- A. (23 09 13.23.A.) Thermostats:
1. Thermostat must:
 - a. energize both "W" and "G" when calling for heat.
 - b. have capability to energize 1 or 2 stages of cooling, and 2 different stages of heating.
 - c. include capability for occupancy scheduling.

Part 4 — (23 09 33) Electric and Electronic Control System for HVAC

4.01 (23 09 33.13) Decentralized, Rooftop Units:

- A. (23 09 33.13.A.) General:
1. Shall be complete with self-contained low-voltage control circuit protected by a resettable circuit breaker on the 24-v transformer side. Transformer shall have 75VA capability.
 2. Shall utilize color-coded wiring.
 3. Shall include a Unit Control Board to conveniently and safely provide connection points for vital control functions such as: smoke

detectors, phase monitor, economizer, thermostat, and low and high pressure switches. Controller shall also provide an intuitive means to adjust the indoor fan speed through a simple switch and pot adjustment design.

4. Unit shall include a minimum of one 8-pin screw terminal connection board for connection of control wiring.

B. (23 09 33.13.B.) Safeties:

1. Compressor over-temperature, over-current. High internal pressure differential.

2. Low Pressure Switch.

Low pressure switch shall use different color wire than the high pressure switch. The purpose is to assist the installer and service technician to correctly wire and or troubleshoot the rooftop unit.

3. High Pressure Switch.

High pressure switch shall use different color wire than the low pressure switch. The purpose is to assist the installer and service technician to correctly wire and or troubleshoot the rooftop unit.

4. Mixed Air Auto Reset Temperature Switch.

All cooling units contain a low return air (or mixed air - depending on unit configuration) temperature switch for compressor protection. The switch prevents compressor operation at mixed air temperatures below 60°F (16°C) to ensure long term reliability but allows continued fan and economizer operation (if installed). The switch will automatically reset when the return/mixed air temperature warms above 65°F (18°C) and will allow compressor operation to continue.

5. Heating section shall be provided with the following minimum protections:

High temperature limit switches.

6. A2L Refrigerant Leak Dissipation System (Electromechanical)

a. Leak dissipation system shall consist of control board and A2L sensor certified to UL 60335-2-40.

b. System shall be designed for the life of the unit.

c. Dissipation system shall be automatic, ship pre-wired, and require no additional field connections to thermostat to function.

d. Refrigerant leak sensor shall be installed in UL certified location and orientation. Sensor shall be self-correcting and resettable. Single use refrigerant leak sensor shall not be permitted.

e. Factory installed dissipation controller shall use onboard microprocessor and include:

- 1) Automatic reset after a dissipation event has occurred

Guide specifications — RAF (cont)

- 2) Onboard LED with flash code to indicate current unit status and hardware failures
 - 3) Depressible “Test” button to allow for a system test and recall/reset of leak detection history
 - 4) 24V dry contact alarm terminal to allow for external notification of leak detection
- f. Dissipation control board shall be accessible via normal maintenance locations and LED shall be visible.
- g. Dissipation system shall “Fail Safe” per UL requirements.
- h. Dissipation shall allow smoke and building fire systems to override in case of event.

Part 5 — (23 09 93) Sequence of Operation for HVAC Controls

5.01 (23 09 93.13) Decentralized, Rooftop Units:

- A. (23 09 93.13.A.) INSERT SEQUENCE OF OPERATION

Part 6 — (23 40 13) Panel Air Filters

6.01 (23 40 13.13) Decentralized, Rooftop Units:

- A. (23 40 13.13.A.) Standard Filter Section:
1. Shall consist of factory installed, low velocity, disposable 2 in. thick fiberglass filters of commercially available sizes.
 2. Unit shall use only one filter size. Multiple sizes are not acceptable.
 3. Filters shall be accessible through an access panel with “no-tool” removal as described in the unit cabinet section of this specification (23 81 19.13.G).

Part 7 — (23 81 19) Self-Contained Air Conditioners

7.01 (23 81 19.13) Small-Capacity Self-Contained Air Conditioners:

- A. (23 81 19.13.A.) General:
1. Outdoor, rooftop mounted, electrically controlled, cooling unit utilizing fully hermetic scroll compressors for cooling duty.
 2. Factory assembled, single-piece cooling rooftop unit. Contained within the unit enclosure shall be all factory wiring, piping, controls, and special features required prior to field start-up.
 3. Unit shall use R-454B refrigerant.
 4. Unit shall be installed in accordance with the manufacturer’s instructions.
 5. Unit must be selected and installed in compliance with local, state, and federal codes.
- B. (23 81 19.13.B.) Quality Assurance:
1. Unit meets ASHRAE 90.1 minimum efficiency requirements.

2. Unit shall be rated in accordance with AHRI Standards 340/360.
 3. Unit shall be designed to conform to ASHRAE 15.
 4. Unit shall be UL-tested and certified in accordance with ANSI Z21.47 Standards and UL-listed and certified under Canadian standards as a total package for safety requirements.
 5. Insulation and adhesive shall meet NFPA 90A requirements for flame spread and smoke generation.
 6. Unit casing shall be capable of withstanding 500 hour salt spray exposure per ASTM B117 (scribed specimen).
 7. Unit shall be designed in accordance with ISO 9001, and shall be manufactured in a facility registered by ISO 9001:2015.
 8. Roof curb shall be designed to conform to NRCA Standards.
 9. Unit shall be subjected to a completely automated run test on the assembly line. The data for each unit will be stored at the factory, and must be available upon request.
 10. Unit shall be designed in accordance with UL Standard 60335-1 and 60335-2-40, including testing to withstand rain. Unit shall be IPX4 rated.
 11. Unit shall be constructed to prevent intrusion of snow and tested to prevent snow intrusion into the control box up to 40 mph.
 12. Unit shake tested to assurance level 1, ASTM D4169 to ensure shipping reliability.
- C. (23 81 19.13.C.) Delivery, Storage, and Handling:
1. Unit shall be stored and handled per manufacturer’s recommendations.
 2. Lifted by crane requires either shipping top panel or spreader bars.
 3. Unit shall only be stored or positioned in the upright position.
- D. (23 81 19.13.D.) Project Conditions:
1. As specified in the contract.
- E. (23 81 19.13.E.) Operating Characteristics:
1. Unit shall be capable of starting and running at 115°F (46°C) ambient outdoor temperature meeting maximum load criteria of AHRI Standard 340/360 at ±10% voltage.
 2. Compressor with standard controls shall be capable of operation down to 40°F (4°C) ambient outdoor temperatures.
 3. Unit shall discharge supply air vertically or horizontally as shown on contract drawings.
 4. Unit shall be factory configured for either vertical or horizontal supply and return configurations. Unit shall not require field conversion.

Guide specifications — RAF (cont)

F. (23 81 19.13.F.) Electrical Requirements:

1. Main power supply voltage, phase, and frequency must match those required by the manufacturer.

G. (23 81 19.13.G.) Unit Cabinet:

1. Unit cabinet shall be constructed of galvanized steel, and shall be bonderized and coated with a prepainted baked enamel finish on all externally exposed surfaces.
2. Unit cabinet exterior paint shall be: film thickness, (dry) 0.003 in. minimum, gloss (per ASTM D523, 60°F/16°C): 60, Hardness: H-2H Pencil hardness.
3. Evaporator fan compartment interior cabinet insulation shall conform to AHRI Standards 340/360 minimum exterior sweat criteria. Interior surfaces shall be insulated with a minimum 1/2 in. thick, 1 lb density, flexible fiberglass insulation, neoprene coated on the air side. Aluminum foil-faced fiberglass insulation shall be used in the heat compartment.
4. Base of unit shall have a minimum of 4 locations for thru-the-base gas and electrical connections (factory-installed or field-installed), standard.
5. Base Rail:
 - a. Unit shall have base rails on a minimum of 2 sides.
 - b. Holes shall be provided in the base rails for rigging shackles to facilitate maneuvering and overhead rigging.
 - c. Holes shall be provided in the base rail for moving the rooftop by fork truck.
 - d. Base rail shall be a minimum of 16 gauge thickness.
6. Condensate Pan and Connections:
 - a. Shall be a sloped condensate drain pan made of a corrosion resistant material.
 - b. Shall comply with ASHRAE Standard 62.
 - c. Shall use a 3/4 in. 14 NPT drain connection, possible either through the bottom or side of the drain pan. Connection shall be made per manufacturer's recommendations.
7. Top Panel:
 - a. Shall be a multi-top panel with watertight flanges and locking systems.
8. Electrical Connections:
 - a. All unit power wiring shall enter unit cabinet at a single, factory prepared, knockout location.
 - b. Thru-the-base capability.
 - 1) Thru-the-base provisions/connections are available as standard with every unit. When bottom connections are required, field furnished couplings are required.

- 2) No basepan penetration, other than those authorized by the manufacturer, is permitted.

9. Component Access Panels (standard):

- a. Cabinet panels shall be easily removable for servicing.
- b. Unit shall have one factory installed, tool-less, removable, filter access panel.
- c. Panels covering control box, indoor fan, indoor fan motor, gas components (where applicable), and compressors shall have molded composite handles.
- d. Handles shall be UV modified, composite. They shall be permanently attached, and recessed into the panel.
- e. Screws on the vertical portion of all removable access panel shall engage into heat resistant, molded composite collars.
- f. Collars shall be removable and easily replaceable using manufacturer recommended parts.

H. (23 81 19.13.H.) Coils:

1. Standard Aluminum Fin-Copper Tube Coils:
 - a. Standard evaporator and condenser coils shall have aluminum lanced plate fins mechanically bonded to seamless internally grooved copper tubes with all joints brazed.
 - b. Evaporator coils shall be leak tested to 150 psig, pressure tested to 450 psig, and qualified to UL 60335-2-40 burst test at 1775 psig.
 - c. Condenser coils shall be leak tested to 150 psig, pressure tested to 650 psig, and qualified to UL 60335-2-40burst test at 1980 psig.
2. Optional Pre-coated Aluminum-Fin Condenser Coils:
 - a. Shall have a durable epoxy-phenolic coating to provide protection in mildly corrosive coastal environments.
 - b. Coating shall be applied to the aluminum fin stock prior to the fin stamping process to create an inert barrier between the aluminum fin and copper tube.
 - c. Epoxy-phenolic barrier shall minimize galvanic action between dissimilar metals.
 - d. Corrosion durability of fin stock shall be confirmed through testing to be no less than 1000 hours salt spray per ASTM B117.
 - e. Corrosion durability of fin stock shall be confirmed through testing to have no visible corrosion after 48 hour immersion in a room temperature solution of 5% salt, 1% acetic acid.
 - f. Fin stock coating shall pass 2000 hours of the following: one week exposure in the

Guide specifications — RAF (cont)

prohesion chamber followed by one week of accelerated ultraviolet light testing. Prohesion chamber: the solution shall contain 3.5% sodium chloride and 0.35% ammonium sulfate. The exposure cycle is one hour of salt fog application at ambient followed by one hour drying at 95°F (35°C).

3. Optional Copper-Fin Evaporator and Condenser Coils:
 - a. Shall be constructed of copper fins mechanically bonded to copper tubes and copper tube sheets.
 - b. Galvanized steel tube sheets shall not be acceptable.
 - c. A polymer strip shall prevent coil assembly from contacting the sheet metal coil pan to minimize potential for galvanic corrosion between coil and pan.
4. Optional E-coated Aluminum-Fin Evaporator and Condenser Coils:
 - a. Shall have a flexible epoxy polymer coating uniformly applied to all coil surface areas without material bridging between fins.
 - b. Coating process shall ensure complete coil encapsulation of tubes, fins and headers.
 - c. Color shall be high gloss black with gloss per ASTM D523.
 - d. Uniform dry film thickness from 0.8 to 1.2 mil on all surface areas including fin edges.
 - e. Superior hardness characteristics of 2H per ASTM D3363 and cross-hatch adhesion of 4B-5B per ASTM D3359.
 - f. Impact resistance shall be up to 160 in.-lb (ASTM D2794).
 - g. Humidity and water immersion resistance shall be up to minimum 1000 and 250 hours respectively (ASTM D2247 and ASTM D870).
 - h. Corrosion durability shall be confirmed through testing to be no less than 1000 hours salt spray per ASTM B117.
- I. (23 81 19.13.I.) Refrigerant Components:
 1. Refrigerant circuit shall include the following control, safety, and maintenance features:
 - a. Thermostatic Expansion Valve (TXV) shall help provide optimum performance across the entire operating range. Shall contain removable power element to allow change out of power element and bulb without removing the valve body.
 - b. Refrigerant filter drier — Solid core design with pre and post filter service gauge connections for filter diagnostics and maintenance.
 - c. Service gauge connections on suction and discharge lines.
 - d. Pressure gauge access through a specially designed access port in the unit.
2. There shall be gauge line access port in the skin of the rooftop, covered by a black, removable plug.
 - a. The plug shall be easy to remove and replace.
 - b. When the plug is removed, the gauge access port shall enable maintenance personnel to route their pressure gauge lines.
 - c. This gauge access port shall facilitate correct and accurate condenser pressure readings by enabling the reading with the compressor access panel on.
 - d. The plug shall be made of a leak proof, UV-resistant, composite material.
3. Compressors:
 - a. Unit shall use tandem scroll compressor assembly on a on single independent refrigeration circuit with two stages of cooling for efficient comfort cooling operation.
 - b. Evaporator coils shall be a full active design to help better control comfort latent removal and minimize unconditioned bypass air.
 - c. Compressor motors shall be cooled by refrigerant gas passing through motor windings.
 - d. Compressors shall be internally protected from high discharge temperature conditions.
 - e. Compressors shall be protected from an over-temperature and over-ampage conditions by an internal, motor overload device.
 - f. Compressor shall be factory mounted on rubber grommets.
 - g. Compressor motors shall have internal line break thermal, current overload and high pressure differential protection.
 - h. Crankcase heaters shall not be required for normal operating range, unless required by compressor manufacturer due to refrigerant charge limits.
- J. (23 81 19.13.J.) Filter Section:
 1. Filters access is specified in the unit cabinet section of this specification.
 2. Filters shall be held in place by a pivoting filter tray, facilitating easy removal and installation.
 3. Shall consist of factory installed, low velocity, throw-away 2 in. thick fiberglass filters.
 4. Filters shall be standard, commercially available sizes.
 5. Only one size filter per unit is allowed.
- K. (23 81 19.13.K.) Evaporator Fan and Motor with X-Vane™ Fan Technology:
 1. Direct Drive Evaporator fan motor:
 - a. Shall be a ECM motor design.

Guide specifications — RAF (cont)

- b. Shall be direct drive design for all static options.
 - c. Shall have permanently lubricated bearings.
 - d. Shall have inherent automatic-reset thermal overload protection.
 - e. Shall have slow ramp up to speed capabilities.
 - f. Shall require no fan/motor belts for operation, adjustments and or initial fan speed set up.
 - g. Fan DC voltage set up on Unit Control Board can eliminate the need of removal of blower access door, required on conventional belt drive systems.
 - h. Shall be internally protected from electrical phase reversal and loss.
2. Evaporator Fan:
- a. Shall be easily set with dedicated selection switch and adjustment pot on unit control board.
 - b. Shall provide 2 stage cooling capacity control, the indoor fan speed is automatically controlled to meet the code-compliant low fan speed and 100% at full fan speed operation.
 - c. Blower fan shall be a Vane Axial fan design with fan assembly secured directly to ECM motor. Additional shafts, belts, pulleys/sheaves, and bearing blocks to drive fan shall not be permitted or necessary.
 - d. Additional variable frequency drive to control fan motor speed shall not be permitted or necessary. All speed control electronics must be onboard fan motor assembly.
 - e. Shall be constructed of a cast aluminum stator and high impact composite material on rotor and air inlet casing.
 - f. Shall be a patented / pending design with a corrosion resistant material.
 - g. Shall have slow ramp up to speed capabilities to help reduce sound and comfort issues typically associated with single speed belt drive systems.
 - h. Units shall contain 2 separate vane axial fan assemblies.
 - i. Shall be a slide out design with removal of a few support brackets.
3. Shall include an easily accessible Unit Control Board to conveniently and safely provide connection points for vital control functions such as: smoke detectors, phase monitor, gas controller, economizer, thermostat, and low, high and mixed air temperature switches. Controller shall also provide an intuitive means to adjust the indoor fan speed through a simple switch and pot adjustment design.
- L. (23 81 19.13.L.) Condenser Fans and Motors:
- 1. Condenser Fan Motors:
 - a. Shall be a totally enclosed motor.
 - b. Shall use permanently lubricated bearings.
 - c. Shall have inherent thermal overload protection with an automatic reset feature.
 - d. Shall use a shaft-down design on all sizes.
 - 2. Condenser Fans:
 - a. Shall be a direct-driven propeller type fan.
 - b. Shall have galvalum blades riveted to steel spider that have corrosion-resistant properties and shall be dynamically balanced.
- M. (23 81 19.13.M.) Special Features Options and Accessories:
- 1. Integrated EconomizerONE Low Leak Rate Models.
 - a. Integrated, gear driven opposing modulating blade design type capable of simultaneous economizer and compressor operation.
 - b. Independent modules for vertical or horizontal return configuration shall be available. Vertical return modules shall be available as a factory installed option.
 - c. Damper blades shall be galvanized steel with composite gears. Plastic or composite blades on intake or return shall not be acceptable.
 - d. Shall include all hardware and controls to provide free cooling with outdoor air when temperature and/or humidity are below set points.
 - e. Shall be equipped with gear driven dampers for both the outdoor ventilation air and the return air for positive air stream control.
 - f. Low leak rate shall be equipped with dampers not to exceed 2% leakage at 1 in. wg pressure differential.
 - g. Economizer controller on EconomizerONE models shall be Siemens POL224 that provides:
 - 1) Combined minimum and DCV maximum damper position potentiometers with compressor staging relay.
 - 2) Optional configuration via WLAN stick and Siemens Climatix™¹ smartphone app for easy setup.
 - 3) Functions with solid-state analog enthalpy or dry bulb changeover control sensing.
 - 4) LED indication for free cooling, sensor, and damper operation.
 - 5) One-line LCD interface screen for setup, configuration and troubleshooting.

1. Third-party trademarks and logos are the property of their respective owners.

Guide specifications — RAF (cont)

- 6) On-board Fault Detection and Diagnostics (FDD) that senses and alerts when the economizer is not operating properly, per California Title 24, ASHRAE 90.1 and IECC®1.
- 7) Sensor failure loss of communication identification.
- 8) Capabilities for use with multiple-speed or single speed indoor fan systems.
- 9) Utilize digital sensors: Dry bulb and Enthalpy.
- h. Shall be capable of introducing up to 100% outdoor air.
- i. Shall be equipped with a barometric relief damper capable of relieving up to 100% return air and contain seals that meet ASHRAE 90.1 requirements.
- j. Shall be designed to close damper(s) during loss-of-power situations with spring return built into motor.
- k. Dry bulb outdoor air temperature sensor shall be provided as standard. Enthalpy sensor is also available on factory installed only. Outdoor air sensor set point shall be adjustable and shall range from 40°F to 100°F (4°C to 38°C). Additional sensor options shall be available as accessories.
- l. The economizer controller shall also provide control of an accessory power exhaust unit function. Factory set at 100%, with a range of 0% to 100%.
- m. The economizer shall maintain minimum airflow into the building during occupied period and provide design ventilation rate for full occupancy.
- n. Dampers shall be completely closed when the unit is in the unoccupied mode.
- o. Economizer controller shall accept a 0 to 10 vdc CO₂ sensor input for IAQ/DCV control. In this mode, dampers shall modulate the outdoor air damper to provide ventilation based on the sensor input.
- p. Compressor lockout temperature on POL224 control is adjustable from -45°F to 80°F (-43°C to 26°C), set at a factory default of 32°F (0°C).
- q. Actuator shall be direct coupled to economizer gear. No linkage arms or control rods shall be acceptable.
- r. Shall contain LED indication for free cooling, sensor, and damper operation.
2. Integrated EconomizerONE Ultra Low Leak Rate Models.
 - a. Integrated, gear driven opposing modulating blade design type capable of simultaneous economizer and compressor operation.
 - b. Independent modules for vertical or horizontal return configuration shall be available. Vertical return modules shall be available as a factory-installed option.
 - c. Damper blades shall be galvanized steel with composite gears. Plastic or composite blades on intake or return shall not be acceptable.
 - d. Shall include all hardware and controls to provide free cooling with outdoor air when temperature and/or humidity are below set points.
 - e. Shall be equipped with gear driven dampers for both the outdoor ventilation air and the return air for positive air stream control.
 - f. Ultra Low Leak design meets California Title 24 section 140.4 and ASHRAE 90.1 requirements for 4 cfm per sq ft on the outside air dampers and 10 cfm per sq ft on the return dampers.
 - g. Economizer controller on EconomizerONE models shall be the Siemens POL224 that provides:
 - 1) One-line LCD interface screen for setup, configuration and troubleshooting.
 - 2) Optional configuration via WLAN stick and Siemens Climatix™ smartphone app for easy setup.
 - 3) On-board Fault Detection and Diagnostics (FDD) that senses and alerts when the economizer is not operating properly, per California Title 24, ASHRAE 90.1 and IECC.
 - 4) Sensor failure loss of communication identification.
 - 5) Capabilities for use with multiple-speed indoor fan systems.
 - 6) Digital sensors: Dry bulb and Enthalpy.
 - h. Shall be capable of introducing up to 100% outdoor air.
 - i. Shall be equipped with a barometric relief damper capable of relieving up to 100% return air and contain seals that meet ASHRAE 90.1 requirements.
 - j. Shall be designed to close damper(s) during loss-of-power situations with spring return built into motor.
 - k. Dry bulb outdoor air temperature sensor shall be provided as standard. Enthalpy sensor is also available on factory installed only. Outdoor air sensor setpoint shall be adjustable and shall range from 40°F to 100°F (4°C to 38°C). Additional sensor options shall be available as accessories.
 - l. The economizer controller shall also provide control of an accessory power exhaust unit function. Factory set at 100%, with a range of 0% to 100%.

Guide specifications — RAF (cont)

- m. The economizer shall maintain minimum airflow into the building during occupied period and provide design ventilation rate for full occupancy.
 - n. Dampers shall be completely closed when the unit is in the unoccupied mode.
 - o. Economizer controller shall accept a 0 to 10 vdc CO₂ sensor input for IAQ/DCV control. In this mode, dampers shall modulate the outdoor air damper to provide ventilation based on the sensor input.
 - p. Compressor lockout temperature on POL224 control is adjustable from -45°F to 80°F (-43°C to 26°C), set at a factory default of 32°F (0°C).
 - q. Actuator shall be direct coupled to economizer gear. No linkage arms or control rods shall be acceptable.
 - r. Contains LED indication for free cooling, sensor, and damper operation.
3. Wi-Fi/WLAN Stick for EconomizerONE POL224 (field-installed):
This item allows use of the Siemens Climatix™ mobile application.
4. Two-Position Damper (Field-installed only):
- a. Damper shall be a Two-Position Damper. Damper travel shall be from the full closed position to the field adjustable %-open set point.
 - b. Damper shall include adjustable damper travel from 25% to 100% (full open).
 - c. Damper shall include single or dual blade, gear driven dampers and actuator motor.
 - d. Actuator shall be direct coupled to damper gear. No linkage arms or control rods shall be acceptable.
 - e. Damper will admit up to 100% outdoor air for applicable rooftop units.
 - f. Damper shall close upon indoor (evaporator) fan shutoff and/or loss of power.
 - g. The damper actuator shall plug into the rooftop unit's wiring harness plug. No hard wiring shall be required.
 - h. Outside air hood shall include aluminum water entrainment filter.
5. Manual Damper (Field-installed only):
Manual damper package shall consist of damper, air inlet screen, and rain hood which can be preset to admit up to 25% or 50% outdoor air for year round ventilation.
6. Hot Gas Re-Heat Dehumidification System:
The Hot Gas Re-Heat Dehumidification System shall be factory installed and shall provide greater dehumidification of the occupied space by 2 modes of dehumidification operations in addition to its normal design cooling mode:
- a. Subcooling mode further sub cools the hot liquid refrigerant leaving the condenser coil when both temperature and humidity in the space are not satisfied.
 - b. Hot gas reheat mode shall mix a portion of the hot gas from the discharge of the compressor with the hot liquid refrigerant leaving the condenser coil to create a 2-phase heat transfer in the system, resulting in a neutral leaving air temperature when only humidity in the space is not satisfied.
 - c. Includes low ambient controller.
7. Low Ambient Control Package:
- a. Controller shall control coil head pressure by condenser fan speed modulation or condenser fan cycling and wind baffles.
 - b. Shall consist of solid-state control and condenser coil temperature sensor to maintain condensing temperature between 90°F (32°C) and 110°F (43°C) at outdoor ambient temperatures down to -20°F (-29°C). For full low ambient control range, Winter Start kit is required.
8. Condenser Coil Hail Guard Assembly:
- a. Shall protect against hail and additional coil damage.
 - b. Shall be louvered type.
9. Unit-Mounted, Non-Fused Disconnect Switch:
- a. Available on 17.5 to 27.5 ton units with FLA of 100 amps or less (460/575V) or 200 amps or less (208/230V).
 - b. Switch shall be factory installed, internally mounted.
 - c. National Electric Code (NEC) and UL approved non-fused switch shall provide unit power shutoff.
 - d. Shall be accessible from outside the unit.
 - e. Shall provide local shutdown and lockout capability.
 - f. Sized **only** for the unit as ordered from the factory. Does not accommodate field-installed devices.
10. Convenience Outlet:
- a. Factory Installed Powered Convenience Outlet.
 - 1) Outlet shall be powered from main line power to the rooftop unit.
 - 2) Outlet shall be powered from line side or load side of disconnect by installing contractor, as required by code. If outlet

Guide specifications — RAF (cont)

- is powered from load side of disconnect, unit electrical ratings shall be UL certified and rated for additional outlet amperage.
- 3) Outlet shall be factory-installed and internally mounted with easily accessible 115-v female receptacle.
 - 4) Outlet shall include 15 amp GFI receptacles with independent fuse protection.
 - 5) Voltage required to operate convenience outlet shall be provided by a factory installed step-down transformer.
 - 6) Outlet shall be accessible from outside the unit.
 - 7) Outlet shall include a field installed "Wet in Use" cover.
- b. Factory-Installed Non-Powered Convenience Outlet.
- 1) Outlet shall be powered from a separate 115/120v power source.
 - 2) A transformer shall not be included.
 - 3) Outlet shall be factory-installed and internally mounted with easily accessible 115-v female receptacle.
 - 4) Outlet shall include 15 amp GFI receptacles with independent fuse protection.
 - 5) Outlet shall be accessible from outside the unit.
 - 6) Outlet shall include a field installed "Wet in Use" cover.
- c. Field-Installed Non-Powered Convenience Outlet.
- 1) Outlet shall be powered from a separate 115/120v power source.
 - 2) A transformer shall not be included.
 - 3) Outlet shall be field-installed and internally mounted with easily accessible 115-v female receptacle.
 - 4) Outlet shall include 20 amp GFI receptacles. This kit provides a flexible installation method which allows code compliance for height requirements of the GFCI outlet from the finished roof surface as well as the capability to relocate the outlet to a more convenient location.
 - 5) Outlet shall be accessible from outside the unit.
 - 6) Outlet shall include a field installed "Wet in Use" cover.
11. Thru-the-Base Connectors:
- a. Kits shall provide connectors to permit gas and electrical connections to be brought to the unit through the unit basepan.
 - b. Minimum of 4 connection location per unit.
12. Centrifugal Fan Power Exhaust:
- a. Power exhaust shall be used in conjunction with an integrated economizer.
 - b. Horizontal power exhaust shall be mounted in return ductwork.
 - c. Power exhaust shall be controlled by economizer controller operation. Exhaust fans shall be energized when dampers open past the 0 to 100% adjustable setpoint on the economizer control.
13. Roof Curbs (Vertical):
- a. Full perimeter roof curb with exhaust capability providing separate air streams for energy recovery from the exhaust air without supply air contamination.
 - b. Formed galvanized steel with wood nailer strip and shall be capable of supporting entire unit weight.
 - c. Permits installation and securing of ductwork to curb prior to mounting unit on the curb.
14. Outdoor Air Enthalpy Sensor:
The outdoor air enthalpy sensor shall be used to provide single enthalpy control. When used in conjunction with a return air enthalpy sensor, the unit will provide differential enthalpy control. The sensor allows the unit to determine if outside air is suitable for free cooling.
15. Return Air Enthalpy Sensor:
The return air enthalpy sensor shall be used in conjunction with an outdoor air enthalpy sensor to provide differential enthalpy control.
16. Indoor Air Quality (CO₂) Sensor:
- a. Shall be able to provide demand ventilation indoor air quality (IAQ) control.
 - b. The IAQ sensor shall be available in duct mount, wall mount, or wall mount with LED display. The setpoint shall have adjustment capability.
17. Smoke Detectors:
- a. Shall be a 4-wire controller and detector.
 - b. Shall be environmental compensated with differential sensing for reliable, stable, and drift-free sensitivity.
 - c. Shall use magnet-activated test/reset sensor switches.
 - d. Shall have tool-less connection terminal access.
 - e. Shall have a recessed momentary switch for testing and resetting the detector.
 - f. Controller shall include:
 - 1) One set of normally open alarm initiation contacts for connection to an initiating device circuit on a fire alarm control panel.

Guide specifications — RAF (cont)

- 2) Two Form-C auxiliary alarm relays for interface with rooftop unit or other equipment.
 - 3) One Form-C supervision (trouble) relay to control the operation of the Trouble LED on a remote test/reset station.
 - 4) Capable of direct connection to 2 individual detector modules.
 - 5) Can be wired to up to 14 other duct smoke detectors for multiple fan shut-down applications.
18. Winter Start Kit:
- a. Shall contain a bypass device around the low pressure switch.
 - b. Shall be required when mechanical cooling is required down to 40°F (4°C).
 - c. Shall not be required to operate on an economizer when below an outdoor ambient of 40°F (4°C).
19. Time Guard:
- a. Shall prevent compressor short-cycling by providing a 5 minute delay (± 2 minutes) before restarting a compressor after shut-down for any reason.
 - b. One device shall be required per compressor.
20. Hinged Access Panels:
- a. Shall provide easy access through integrated quarter turn latches.
 - b. Shall be on major panels of: filter, control box, fan motor, and compressor.
21. Condensate Overflow Switch:
- This sensor and related controller monitors the condensate level in the drain pan and shuts down compression operation when overflow conditions occur. It includes:
- a. Indicator light — solid red (more than 10 seconds on water contact — compressors disabled), blinking red (sensor disconnected).
 - b. 10 second delay to break — eliminates nuisance trips from splashing or waves in pan (sensor needs 10 seconds of constant water contact before tripping).
 - c. Disables the compressor(s) operation when condensate plug is detected, but still allows fans to run for Economizer.
22. 4 in. Return Air Rack (Field Installed Only):
- a. Accessory kit is designed to hold 4 in. MERV-8 or MERV-13 filters. Filters not included in kit.
23. Phase Monitor Control:
- a. Shall monitor the sequence of 3-phase electrical system to provide a phase reversal protection.
 - b. Shall monitor the 3-phase voltage inputs to provide a phase loss protection for the 3-phase device.
 - c. Will work on either a Delta or Wye power connection.
24. Horn/Strobe Annunciator:
- a. Provides an audible/visual signaling device for use with factory-installed option or field installed accessory smoke detectors.
 - b. Requires installation of a field-supplied 24-v transformer suitable for 4.2 VA (AC) or 3.0 VA (DC) per horn/strobe accessory.
 - c. Requires field-supplied electrical box, North American 1-gang box, 2 in. x 4 in. (51 mm x 102 mm).
 - d. Shall have a clear colored lens.
25. Electric Heat:
- a. Heating Section:
 - 1) Heater element open coil resistance wire, nickel-chrome alloy, 0.29 inches inside diameter, strung through ceramic insulators mounted on metal frame. Coil ends are staked and welded to terminal screw slots.
 - 2) Heater assemblies are provided with integral fusing for protection of internal heater circuits not exceeding 48 amps each. Auto reset thermo limit controls, magnetic heater contactors (24-v coil) and terminal block all mounted in electric heater control box (minimum 18 ga galvanized steel) attached to end of heater assembly.
26. High Short Circuit Current Rating (SCCR) Protection:
- a. Factory-installed option shall provide high short circuit current protection to compressor and all indoor and outdoor fan motors rated at 60 kA (208/230V) or 65kA (460V) against high potential fault current situations. (Standard unit comes with 5 kA rating.)
 - b. This option is not available with factory installed Hot Gas Re-Heat system, Powered Convenience Outlet, Non-Fused Disconnect, Low Ambient controls, Phase Loss monitor/protection and 575 Volt models.

© 2025 Carrier
Lewisburg, Tennessee 37091 USA
www.GoHeil.com