



RGF-RAF-090-180 Product Specifications

SINGLE PACKAGE ROOFTOP UNITS WITH X-VANE™ FAN TECHNOLOGY: GAS HEATING/ELECTRIC COOLING (RGF) AND ELECTRIC COOLING/OPTIONAL ELECTRIC HEAT (RAF) 7.5 TO 15 TON

The new 7.5 to 15 Ton RGF/RAF090-180 Series rooftop units (RTU) with X-Vane Fan Technology provides value added benefits never seen in this type of equipment before. New major design features include:

- Environmentally balanced R-454B refrigerant, which delivers a 75% reduction in global warming potential (GWP) compared to R-410A. R-454B's GWP of 466 easily exceeds the EPA (Environmental Protection Agency) requirement of <700 GWP.
- Patented, industry's first efficient indoor fan system using Vane Axial fan with electronically commutated variable speed motor. As compared to today's typically used belt drive with forward curve fans, system provides reliable operation with:
 - 75% fewer moving parts
 - No fan belts, pulleys, shaft, and shaft bearings
 - 40% more efficient than traditional belt drive forward curve fans
 - Slow ramp up capability for better sound and comfort control
 - Internal protection from phase reversal and phase loss situations
 - High external static capability
 - Slide out blower assembly design
- Reliable and highly safety protected 2 stage cooling with tandem scroll compressors technology, fully active evaporator coil, and mixed air temperature protection on all models
- New unit control board with intuitive indoor fan that uses simple dial and switch adjustments
- Reliable copper tube/aluminum fin condenser coil with 5/16 in. tubing to help reduce refrigerant charge and reduce weight versus prior designs

RGF/RAF units up to 15 tons are specifically designed to fit on existing roof curbs that were installed back to 1989, which makes replacement easy and eliminates the need for curb adapters, changing utility connections or supporting curb overhang situations.

Two-speed indoor fan motor system helps deliver IEERs up to 15.2. All models are capable of either vertical or horizontal air-flow without dedicated models or field install kits. The 15 ton models require a field-installed supply air kit.

With "no-strip" screw collars, handled access panels, and more, the unit is easy to install, easy to maintain, and easy to use. Your new 7.5 to 15 ton RGF/RAF rooftop unit (RTU) provides optimum comfort and control from a packaged rooftop.

Installation ease

All RGF/RAF090-180 units are field-convertible to horizontal airflow, which makes it easy to adjust to unexpected job-site complications. Lighter units make for easy replacement and aid in the structural approval process. Units have simple, fast plug-in connections to the standard integrated unit control board (UCB). Clearly labeled connections points to reduce installation time. Also, a large control box provides room to work.

Easy to maintain

With the X-Vane vane axial fan system and a direct drive ECM motor, belts and pulleys are a thing of the past. This frees up maintenance, installation and commissioning time. Should an adjustment be necessary, it can easily be made via the UCB in the control box. For regular service activities, our easy-access handles provide a quick solution to all commonly accessed service panels, and our sloped, corrosion-resistant composite drain pan sheds water and will not rust. Service gauge connections are included on compressor suction/discharge lines before and after the filter drier to monitor system operation during maintenance.



RGF/RAF090-180

X-Vane Fan™

Table of contents

	PAGE		PAGE
FEATURES/BENEFITS	3	FAN DATA	61
MODEL NUMBER NOMENCLATURE	4	ELECTRICAL DATA	102
CAPACITY RATINGS	6	TYPICAL WIRING DIAGRAMS	131
PHYSICAL DATA	9	SEQUENCE OF OPERATION	143
OPTIONS AND ACCESSORIES	13	APPLICATION DATA	146
BASE UNIT DIMENSIONS	18	GUIDE SPECIFICATIONS — RGF	148
ACCESSORY DIMENSIONS	36	GUIDE SPECIFICATIONS — RAF	159
PERFORMANCE DATA	38		

R-4545B Features

With a GWP of 466 and similar working pressure and performance to R-410A, R-454B easily exceeds the EPA's new, stringent <700 GWP refrigerant requirement while minimizing unit redesign. Like other next generation refrigerants (R-32, etc.), R-454B is classified as an "A2L" refrigerant by ASHRAE^{®1} (American Society of Heating, Refrigerating, and Air-Conditioning Engineers). This designation means that R-454B is "mildly flammable" under certain conditions. While this is a change from legacy "A1 — No Flame Propagation" refrigerants like R-410A, A2Ls are still very low on the flammability scale and quite safe for use. A2L refrigerants are difficult to ignite and have an extremely low flame speed — much less so than natural gas, propane, or even rubbing alcohol. We are committed to safety. As such, all of our R-454B rooftop units include a factory-installed dissipation control board and leak sensor designed to last the lifetime of the unit. This system is certified to UL 60335-2-40 and designed to work right away, without any field configuration or wiring. In the event of a leak, these systems automatically identify and resolve the issue by safely dissipating the refrigerant to ensure there is no risk to equipment, buildings, or occupants.

Easy to use

The newly re-designed Unit Control Board puts all connections and troubleshooting points in one convenient place. Most low voltage connections are made to the same board and make it easy to access. Setting up the fan is simple, using an intuitive switch and rotary dial arrangement. RGF/RAF090-180 rooftops have high and low pressure switches, a new mixed air temperature switch, a filter drier, and 2 in. filters standard.

X-Vane Fan Technology

Direct drive X-Vane Fan Technology indoor fan system uses vane axial fan design and electrically commutated motors. This new Vane Axial design, compared to past belt drive systems, has 75% fewer moving parts, uses up to 40% less energy, and has no fan belts, blower bearings, or shaft.

Features/Benefits

Design features include:

- Two-stage units deliver IEERs up to 15.2.
- All models are capable of either vertical or horizontal airflow.
- RGF/RAF090-180 rooftop units (RTU) were designed by customers for customers. With “no-strip” screw collars, handled access panels, and more the unit is easy to install, easy to maintain, and easy to use. Your new 7.5 to 15 ton RGF/RAF090-180 rooftop unit (RTU) provides optimum comfort and control from a packaged rooftop.

Value-added features include:

- Optional Hot Gas Re-Heat dehumidification system for improved part load humidity performance
- Single point gas and electrical connections
- 7.5 to 15 ton models use TXV refrigerant metering device
- Scroll compressors with internal line-break overload protection
- Units come with an easy access tool-less filter door. Filter track tilts out for filter removal and replacement. All filters are the same size in each unit

Operating efficiency and flexibility

These RGF/RAF packaged rooftops meet the Department of Energy (DOE) 2023 efficiency standard, as well as the latest ASHRAE (American Society of Heating, Refrigerating, and Air-Conditioning Engineers) 90.1 and IECC^{®1} (International Energy Conservation Code) minimum IEER efficiency requirements.

Field convertible airflow

All RGF/RAF090-180 units are field-convertible to horizontal airflow, which makes it easy to adjust to unexpected jobsite complications. The 15 ton models require a simple supply duct cover kit to field convert from factory vertical to horizontal.

Comfort control

Our patented Hot Gas Re-Heat dehumidification system is an all-inclusive factory-installed option on gas heating/electric cooling and electric cooling/electric heat models. This system provides reliable, flexible operation to meet indoor part load sensible and latent requirements as well as multiple gas heat and electric heat sized to fit an array of applications.

1. Third-party trademarks and logos are the property of their respective owners.

Model number nomenclature

RGF090-180 Model Number Nomenclature

MODEL SERIES	R	G	F	0	9	0	L	D	2	A	0	A	A	A
Position Number	1	2	3	4	5	6	7	8	9	10	11	12	13	14
R = Rooftop														
G = Gas Heat / Electric Cooling	Type													
F = Standard Efficiency Packaged RTU with X-Vane™ Technology	Unit Efficiency													
090 = 90,000, 7.5 Tons 102 = 102,000, 8.5 Tons 120 = 120,000, 10.0 Tons 150 = 150,000, 12.5 Tons 180 = 180,000, 15.0 Tons	Nominal Cooling Capacity													
H = 208-230/3/60 L = 460/3/60 S = 575/3/60	Voltage													
D = Low Gas Heat ^a E = Medium Gas Heat F = High Gas Heat S = Low Gas Heat, Stainless Steel Heat Exchanger ^a R = Medium Gas Heat, Stainless Steel Heat Exchanger T = High Gas Heat, Stainless Steel Heat Exchanger	Heating Capacity													
2 = Standard/Medium Static X-Vane Fan 3 = High Static X-Vane Fan 4 = High Static X-Vane Fan and Hot Gas Re-Heat 5 = Standard/Medium Static X-Vane Fan and Filter Status Switch 6 = High Static X-Vane Fan and Filter Status Switch 7 = High Static X-Vane Fan and Filter Status Switch with Hot Gas Re-Heat	Motor (Indoor Fan)													
A = None B = Temperature Economizer with Barometric Relief F = Enthalpy Economizer with Barometric Relief L = ULL (Ultra Low Leak) Temperature Economizer with Barometric Relief and CO ₂ Sensor M = ULL Enthalpy Economizer with Barometric Relief and CO ₂ Sensor U = ULL Temperature Economizer with Barometric Relief W = ULL Enthalpy Economizer with Barometric Relief	Outdoor Air Options / Control													
0A - None Note: See the RGF 7.5 to 15 Ton Specification Sheet for Factory Installed Options	Factory Installed Options^b													
A = Al/Cu - Al/Cu B = Precoat Al/Cu - Al/Cu C = E-coat Al/Cu - Al/Cu D = E-coat Al/Cu - E-coat Al/Cu M = Al/Cu - Al/Cu — Louvered Hail Guard N = Precoat Al/Cu - Al/Cu — Louvered Hail Guard P = E-coat Al/Cu - Al/Cu — Louvered Hail Guard Q = E-coat Al/Cu - E-coat Al/Cu — Louvered Hail Guard R = Cu/Cu - Al/Cu — Louvered Hail Guard S = Cu/Cu - Cu/Cu — Louvered Hail Guard	Condenser / Evaporator Coil Configuration													
A = Standard Electromechanical Controls	Controls													

NOTE(S):

^aNot available for Voltage code S (575/3/60) units.

^bCombinations of factory-installed options are available, see Specifications Sheet for details.

Model number nomenclature (cont)

RAF090-180 Model Number Nomenclature

MODEL SERIES	R	A	F	0	9	0	L	0	2	A	0	A	A	A
Position Number	1	2	3	4	5	6	7	8	9	10	11	12	13	14
R = Rooftop														
A = Electric Heat / Electric Cooling	Type													
F = Standard Efficiency Packaged RTU with X-Vane™ Technology	Unit Efficiency													
090 = 90,000, 7.5 Tons 102 = 102,000, 8.5 Tons 120 = 120,000, 10.0 Tons 150 = 150,000, 12.5 Tons 180 = 180,000, 15.0 Tons	Nominal Cooling Capacity													
H = 208-230/3/60 L = 460/3/60 S = 575/3/60	Voltage													
0 = No Heat	Heating Capacity													
2 = Standard/Medium Static X-Vane Fan 3 = High Static X-Vane Fan 4 = High Static X-Vane Fan and Hot Gas Re-Heat 5 = Standard/Medium Static X-Vane Fan and Filter Status Switch 6 = High Static X-Vane Fan and Filter Status Switch 7 = High Static X-Vane Fan and Filter Status Switch with Hot Gas Re-Heat	Motor (Indoor Fan)													
A = None B = Temperature Economizer with Barometric Relief F = Enthalpy Economizer with Barometric Relief L = ULL (Ultra Low Leak) Temperature Economizer with Barometric Relief and CO ₂ Sensor M = ULL Enthalpy Economizer with Barometric Relief and CO ₂ Sensor U = ULL Temperature Economizer with Barometric Relief W = ULL Enthalpy Economizer with Barometric Relief	Outdoor Air Options / Control													
0A - None Note: See the RAF 7.5 to 15 Ton Specification Sheet for Factory Installed Options	Factory Installed Options^a													
A = Al/Cu - Al/Cu B = Precoat Al/Cu - Al/Cu C = E-coat Al/Cu - Al/Cu D = E-coat Al/Cu - E-coat Al/Cu M = Al/Cu - Al/Cu — Louvered Hail Guard N = Precoat Al/Cu - Al/Cu — Louvered Hail Guard P = E-coat Al/Cu - Al/Cu — Louvered Hail Guard Q = E-coat Al/Cu - E-coat Al/Cu — Louvered Hail Guard R = Cu/Cu - Al/Cu — Louvered Hail Guard S = Cu/Cu - Cu/Cu — Louvered Hail Guard	Condenser / Evaporator Coil Configuration													
A = Standard Electromechanical Controls	Controls													

NOTE(S):

^aCombinations of factory-installed options are available, see Specifications Sheet for details.

Capacity ratings

RGF AHRI Ratings^{a,b,c,d}

RGF UNITS	COOLING STAGES	NOMINAL CAPACITY (tons)	NET COOLING CAPACITY (MBH)	TOTAL POWER (kW)	EER	IEER WITH 2-SPEED INDOOR FAN MOTOR	AHRI RATING CFM	AHRI PART LOAD CFM
RGF090	2	7.5	86	7.7	11.2	15.0	2650	1575
RGF102	2	8.5	98	8.8	11.2	15.0	3400	1700
RGF120	2	10.0	118	10.7	11.0	15.0	3500	2100
RGF150	2	12.5	136	12.6	10.8	15.0	3750	2250
RGF180	2	15.0	174	16.1	10.8	14.5	5250	3500

NOTE(S):

- a. Rated in accordance with AHRI Standards 340/360.
- b. Rating are based on:
Cooling Standard: 80°F (27°C) db, 67°F (19°C) wb indoor air temperature and 95°F (35°C) db outdoor air temperature.
IEER Standard: A measure that expresses cooling part-load EER efficiency for commercial unitary air-conditioning and heat pump equipment on the basis of weighted operation at various load capacities.
- c. All RGF090-180 units comply with ASHRAE 90.1-2019 (American Society of Heating, Refrigerating, and Air-Conditioning Engineers) and DOE-2023 (Department of Energy) Energy Standard for minimum IEER requirements.
- d. RGF090-180 units comply with US Energy Policy Act (2005). To evaluate code compliance requirements, refer to state and local codes.

LEGEND

- AHRI — Air-Conditioning, Heating and Refrigeration Institute
- EER — Energy Efficiency Ratio
- IEER — Integrated Energy Efficiency Ratio

RAF AHRI Ratings^{a,b,c,d}

RAF UNITS	COOLING STAGES	NOMINAL CAPACITY (tons)	NET COOLING CAPACITY (MBH)	TOTAL POWER (kW)	EER	IEER WITH 2-SPEED INDOOR FAN MOTOR	AHRI RATING CFM	AHRI PART LOAD CFM
RAF090	2	7.5	86	7.5	11.4	15.2	2650	1575
RAF102	2	8.5	98	8.6	11.4	15.2	3400	1700
RAF120	2	10.0	118	10.5	11.2	15.2	3500	2100
RAF150	2	12.5	136	12.1	11.0	15.2	3750	2250
RAF180	2	15.0	174	15.8	11.0	14.7	5250	3500

NOTE(S):

- a. Rated in accordance with AHRI Standards 340/360.
- b. Rating are based on:
Cooling Standard: 80°F (27°C) db, 67°F (19°C) wb indoor air temperature and 95°F (35°C) db outdoor air temperature.
IEER Standard: A measure that expresses cooling part-load EER efficiency for commercial unitary air-conditioning and heat pump equipment on the basis of weighted operation at various load capacities.
- c. All RAF090-180 units comply with ASHRAE 90.1-2019 (American Society of Heating, Refrigerating, and Air-Conditioning Engineers) and DOE-2023 (Department of Energy) Energy Standard for minimum IEER requirements.
- d. RAF090-180 units comply with US Energy Policy Act (2005). To evaluate code compliance requirements, refer to state and local codes.

LEGEND

- AHRI — Air-Conditioning, Heating and Refrigeration Institute
- EER — Energy Efficiency Ratio
- IEER — Integrated Energy Efficiency Ratio



Capacity ratings (cont)

Heat Rating Table — Natural Gas And Propane

RGF UNITS	GAS HEAT	AL/SS HEAT EXCHANGER		TEMPERATURE RISE (°F)	THERMAL EFFICIENCY (%)
		Input/Output Stage 1 (MBH)	Input/Output Stage 2 (MBH)		
RGF090	LOW	—/—	125/103	25-55	82
	MED	120/98	180/148	35-65	82
	HIGH	180/146	224/181	40-75	81
RGF102	LOW	—/—	125/103	20-55	82
	MED	120/98	180/148	30-65	82
	HIGH	180/146	224/181	35-75	81
RGF120	LOW	120/98	180/148	25-65	82
	MED	180/146	224/181	30-65	81
	HIGH	200/164	250/205	35-70	82
RGF150	LOW	120/98	180/148	20-65	82
	MED	180/146	224/181	25-65	81
	HIGH	200/160	250/205	30-70	82
RGF180	LOW	144/118	180/146	15-55	81
	MED	192/156	240/195	20-60	81
	HIGH	280/224	350/284	35-65	81

LEGEND

MBH — Btuh in thousands

Capacity ratings (cont)

Sound Ratings Table^{a,b}

RGF/RAF UNITS	COOLING STAGES	OUTDOOR SOUND (dB) at 60 Hz								
		A-WEIGHTED ^c	63	125	250	500	1000	2000	4000	8000
090	2	79	85.6	84.7	80.5	76.0	72.4	68.0	62.8	59.3
102	2	79	85.6	84.7	80.5	76.0	72.4	68.0	62.8	59.3
120	2	79	85.6	84.7	80.5	76.0	72.4	68.0	62.8	59.3
150	2	79	85.6	84.7	80.5	76.0	72.4	68.0	62.8	59.3
180	2	87	87.0	85.2	84.6	84.9	82.2	78.4	75.3	72.9

NOTE(S):

- Outdoor sound data is measured in accordance with AHRI.
- Measurements are expressed in terms of sound power. Do not compare these values to sound pressure values because sound pressure depends on specific environmental factors which normally do not match individual applications. Sound power values are independent of the environment and therefore more accurate.
- A-weighted sound ratings filter out very high and very low frequencies, to better approximate the response of "average" human ear. A-weighted measurements for RGF/RAF units are taken in accordance with AHRI.

LEGEND

dB — Decibel

Minimum - Maximum Airflow Ratings (cfm) — Natural Gas and Propane

RGF UNITS	HEAT LEVEL	COOLING			HEATING ^a	
		Minimum 2-Speed Airflow (Low Speed)	Minimum 2-Speed Airflow (High Speed)	Maximum Airflow cfm	Minimum Airflow cfm	Maximum Airflow cfm
RGF090	LOW	1350	2250	3750	1730	3800
	MED				2100	3900
	HIGH				2240	4200
RGF102	LOW	1275	2550	4250	1730	4750
	MED				2100	4560
	HIGH				2240	4800
RGF120	LOW	1800	3000	5000	2100	5470
	MED				2580	5600
	HIGH				2710	5420
RGF150	LOW	2250	3750	6250	2100	6830
	MED				2580	6720
	HIGH				2710	6330
RGF180	LOW	2970	4500	7500	2450	9000
	MED				3000	9000
	HIGH				4040	7500

NOTE(S):

- Heating rating values are identical for aluminum heat exchangers and stainless steel heat exchangers.

Minimum - Maximum Airflow Ratings (cfm) — Cooling Units and Accessory Electric Heat

RAF UNITS	COOLING			ELECTRIC HEAT ^a	
	Minimum 2-Speed Airflow (Low Speed)	Minimum 2-Speed Airflow (High Speed)	Maximum Airflow cfm	Minimum Airflow cfm	Maximum Airflow cfm
RAF090	1350	2250	3750	2250	3750
RAF102	1275	2550	4250	2550	4250
RAF120	1800	3000	5000	3000	5000
RAF150	2250	3750	6250	3750	6250
RAF180	2970	4500	7500	4500	7500

NOTE(S):

- Electric heat modules and single point kits are available as field-installed accessories for RAF units.

Physical data

RGF/RAF 7.5 to 8.5 Ton Physical Data

RGF/RAF UNIT	RGF/RAF090**2/3/5/6	RGF/RAF090**4/7	RGF/RAF102**2/3/5/6	RGF/RAF102**4/7
NOMINAL TONS	7.5	7.5	8.5	8.5
BASE UNIT OPERATING WT (lb) RGF/RAF^a	787/743	787/743	868/805	868/805
REFRIGERATION SYSTEM				
No. Circuits/No. Compressors/Type	1 / 2 / Scroll	1 / 2 / Scroll	1 / 2 / Scroll	1 / 2 / Scroll
R-454B Charge (lb-oz)	10-3	—	10-12	—
Hot Gas Re-Heat R-454B Charge (lb-oz)	—	13-4	—	17-14
Metering Device	TXV	—	TXV	—
Hot Gas Re-Heat Metering Device	—	TXV	—	TXV
High-Pressure Trip/Reset (psig)	630/505	630/505	630/505	630/505
Low-Pressure Trip/Reset (psig)	54/117	54/117	54/117	54/117
EVAPORATOR COIL				
Material (Tube/Fin)	Cu/Al	Cu/Al	Cu/Al	Cu/Al
Coil Type	3/8 in. RTPF	3/8 in. RTPF	3/8 in. RTPF	3/8 in. RTPF
Rows/FPI	3/15	3/15	4/15	4/15
Total Face Area (ft ²)	8.9	8.9	11.1	11.1
Condensate Drain Connection Size	3/4 in.	3/4 in.	3/4 in.	3/4 in.
CONDENSER COIL				
Material	Cu/Al	Cu/Al	Cu/Al	Cu/Al
Coil Type	5/16 in. RTPF	5/16 in. RTPF	5/16 in. RTPF	5/16 in. RTPF
Rows/FPI	2/18	2/18	2/18	2/18
Total Face Area (ft ²)	20.5	20.5	21.4	21.4
HOT GAS RE-HEAT COIL				
Material	—	Cu/Al	—	Cu/Al
Coil Type	—	5/16 in. RTPF	—	5/16 in. RTPF
Rows/FPI	—	2/18	—	2/18
Total Face Area (ft ²)	—	6.0	—	8.0
EVAPORATOR FAN AND MOTOR				
Standard/Medium Static				
Motor Qty / Drive Type	1 / Direct	1 / Direct	1 / Direct	1 / Direct
Max Cont bhp	2.4	2.4	2.4	2.4
Range (rpm)	250-2000	250-2000	250-2000	250-2000
Fan Qty/Type	1/Vane Axial	1/Vane Axial	1/Vane Axial	1/Vane Axial
Fan Diameter (in.)	22	22	22	22
High Static				
Motor Qty / Drive Type	1 / Direct	1 / Direct	1 / Direct	1 / Direct
Max Cont bhp	3	3	3	3
Range (rpm)	250-2200	250-2200	250-2200	250-2200
Fan Qty/Type	1/Vane Axial	1/Vane Axial	1/Vane Axial	1/Vane Axial
Fan Diameter (in.)	22	22	22	22
CONDENSER FAN AND MOTOR				
Qty / Motor Drive Type	2 / Direct	2 / Direct	2 / Direct	2 / Direct
Motor hp/rpm	1/4 / 1100	1 / 160-1100	1/4 / 1100	1/4 / 160-1100
Fan Diameter (in.)	22	22	22	22
FILTERS				
RA Filter Qty / Size (in.)	4 / 16 x 20 x 2	4 / 16 x 20 x 2	4 / 20 x 20 x 2	4 / 20 x 20 x 2
OA Inlet Screen Qty / Size (in.)	1 / 20 x 24 x 1	1 / 20 x 24 x 1	1 / 20 x 24 x 1	1 / 20 x 24 x 1

NOTE(S):

a. Base unit operating weight does not include weight of options.

LEGEND

bhp — Brake Horsepower
FPI — Fins Per Inch
OA — Outdoor Air
RA — Return Air

Physical data (cont)

RGF/RAF 10 to 12.5 Ton Physical Data

RGF/RAF UNIT	RGF/RAF120**2/3/5/6	RGF/RAF120**4/7	RGF/RAF150**2/3/5/6	RGF/RAF150**4/7
NOMINAL TONS	10.0	10.0	12.5	12.5
BASE UNIT OPERATING WT (lb) RGF/RAF^a	878/815	878/815	1041/978	1041/978
REFRIGERATION SYSTEM				
No. Circuits/No. Compressors/Type	1 / 2 / Scroll	1 / 2 / Scroll	1 / 2 / Scroll	1 / 2 / Scroll
R-454B Charge (lb-oz)	14-6	—	19-8	—
Hot Gas Re-Heat R-454B Charge (lb-oz)	—	21-12	—	28-4
Metering Device	TXV	—	TXV	—
Hot Gas Re-Heat Metering Device	—	TXV	—	TXV
High-Pressure Trip/Reset (psig)	630/505	630/505	630/505	630/505
Low-Pressure Trip/Reset (psig)	54/117	54/117	54/117	54/117
EVAPORATOR COIL				
Material (Tube/Fin)	Cu/Al	Cu/Al	Cu/Al	Cu/Al
Coil Type	3/8 in. RTPF	3/8 in. RTPF	3/8 in. RTPF	3/8 in. RTPF
Rows/FPI	4/15	4/15	4/15	4/15
Total Face Area (ft ²)	11.1	11.1	11.1	11.1
Condensate Drain Connection Size	3/4 in.	3/4 in.	3/4 in.	3/4 in.
CONDENSER COIL				
Material	Cu/Al	Cu/Al	Cu/Al	Cu/Al
Coil Type	5/16 in. RTPF	5/16 in. RTPF	5/16 in. RTPF	5/16 in. RTPF
Rows/FPI	2/18	2/18	3/18	3/18
Total Face Area (ft ²)	25.1	25.1	25.1	25.1
HOT GAS RE-HEAT COIL				
Material	—	Cu/Al	—	Cu/Al
Coil Type	—	5/16 in. RTPF	—	5/16 in. RTPF
Rows/FPI	—	2/18	—	2/18
Total Face Area (ft ²)	—	8.0	—	8.0
EVAPORATOR FAN AND MOTOR				
Standard/Medium Static				
Motor Qty / Drive Type	1 / Direct	1 / Direct	1 / Direct	1 / Direct
Max Cont bhp	2.4	2.4	3	3
Range (rpm)	250-2000	250-2000	250-2200	250-2200
Fan Qty / Type	1 / Vane Axial	1 / Vane Axial	1 / Vane Axial	1 / Vane Axial
Fan Diameter (in.)	22	22	22	22
High Static				
Motor Qty / Drive Type	1 / Direct	1 / Direct	1 / Direct	1 / Direct
Max Cont bhp	5	5	5	5
Range (rpm)	250-2200	250-2200	250-2200	250-2200
Fan Qty / Type	1 / Vane Axial	1 / Vane Axial	1 / Vane Axial	1 / Vane Axial
Fan Diameter (in.)	22	22	22	22
CONDENSER FAN AND MOTOR				
Qty / Motor Drive Type	2 / Direct	2 / Direct	1 / Direct	1 / Direct
Motor hp / rpm	1/4 / 1100	1/4 / 160-1100	1 / Multiple Speeds ^b	1 / Multiple Speeds ^b
Fan Diameter (in.)	22	22	22	22
FILTERS				
RA Filter Qty / Size (in.)	4 / 20 x 20 x 2	4 / 20 x 20 x 2	4 / 20 x 20 x 2	4 / 20 x 20 x 2
OA Inlet Screen Qty / Size (in.)	1 / 20 x 24 x 1	1 / 20 x 24 x 1	1 / 20 x 24 x 1	1 / 20 x 24 x 1

NOTE(S):

- a. Base unit operating weight does not include weight of options.
b. 1050/770/450/350/265 rpm

LEGEND

- bhp** — Brake Horsepower
FPI — Fins Per Inch
OA — Outdoor Air
RA — Return Air

Physical data (cont)

RGF/RAF 15 Ton Physical Data

RGF/RAF UNIT	RGF/RAF180**2/3/5/6	RGF/RAF180**4/7
NOMINAL TONS	15.0	15.0
BASE UNIT OPERATING WT (lb) RGF/RAF^a	1408/1325	1408/1325
REFRIGERATION SYSTEM		
No. Circuits/No. Compressors/Type	1 / 2 / Scroll	1 / 2 / Scroll
R-454B Charge (lb-oz)	22-0	—
Hot Gas Re-Heat R-454B Charge (lb-oz)	—	31-3
Metering Device	TXV	—
Hot Gas Re-Heat Metering Device	—	TXV
High-Pressure Trip/Reset (psig)	630/505	630/505
Low-Pressure Trip/Reset (psig)	54/117	54/117
EVAPORATOR COIL		
Material (Tube/Fin)	Cu/Al	Cu/Al
Coil Type	3/8 in. RTPF	3/8 in. RTPF
Rows/FPI	3/15	3/15
Total Face Area (ft ²)	17.5	17.5
Condensate Drain Connection Size	3/4 in.	3/4 in.
CONDENSER COIL		
Material	Cu/Al	Cu/Al
Coil Type	5/16 in. RTPF	5/16 in. RTPF
Rows/FPI	2/18	2/18
Total Face Area (ft ²)	46.2	46.2
HOT GAS RE-HEAT COIL		
Material	—	Cu/Al
Coil Type	—	5/16 in. RTPF
Rows/FPI	—	2/18
Total Face Area (ft ²)	—	8.0
EVAPORATOR FAN AND MOTOR		
Standard/Medium Static		
Motor Qty / Drive Type	1 / Direct	1 / Direct
Max Cont bhp	3	3
Range (rpm)	250-2200	250-2200
Fan Qty / Type	1 / Vane Axial	1 / Vane Axial
Fan Diameter (in.)	22	22
High Static		
Motor Qty / Drive Type	1 / Direct	1 / Direct
Max Cont bhp	5	5
Range (rpm)	250-2200	250-2200
Fan Qty / Type	1 / Vane Axial	1 / Vane Axial
Fan Diameter (in.)	22	22
CONDENSER FAN AND MOTOR		
Qty / Motor Drive Type	3 / Direct	3 / Direct
Motor hp / rpm	1/4 / 1100	1/4 / 1100
Fan Diameter (in.)	22	22
FILTERS		
RA Filter Qty / Size (in.)	6 / 18 x 24 x 2	6 / 18 x 24 x 2
OA Inlet Screen Qty / Size (in.)	Vertical: 2 / 24 x 27 x 1 Horizontal: 1 / 30 x 39 x 1	Vertical: 2 / 24 x 27 x 1 Horizontal: 1 / 30 x 39 x 1

NOTE(S):

a. Base unit operating weight does not include weight of options.

LEGEND

bhp — Brake Horsepower
FPI — Fins Per Inch
OA — Outdoor Air
RA — Return Air

Physical data (cont)

RGF 7.5 to 15 Ton Gas Heat Data

RGF UNIT	RGF090	RGF102	RGF120	RGF150	RGF180
NOMINAL TONS	7.5	8.5	10.0	12.5	15
GAS CONNECTION					
No. of Gas Valves	1	1	1		1
Natural Gas Supply Line Pressure (in. wg)/(psig)	4-13 / 0.14-0.47	4-13 / 0.14-0.47	4-13 / 0.14-0.47	4-13 / 0.14-0.47	4-13 / 0.14-0.47
Liquid Propane Supply Line Pressure (in. wg)/(psig)	11-13 / 0.40-0.47	11-13 / 0.40-0.47	11-13 / 0.40-0.47	11-13 / 0.40-0.47	11-13 / 0.40-0.47
HEAT ANTICIPATOR SETTING (AMPS)					
First Stage	0.14	0.14	0.14	0.14	0.14
Second Stage	0.14	0.14	0.14	0.14	0.14
NATURAL GAS HEAT					
LOW					
No. of Stages / No. of Burners (total)	1 / 3	1 / 3	2 / 4	2 / 4	2 / 6
Connection Size	1/2 in. NPT	1/2 in. NPT	3/4 in. NPT	3/4 in. NPT	3/4 in. NPT
Rollout Switch Opens / Closes (°F)	195 / 115	195 / 115	195 / 115	196 / 115	196 / 115
Temperature Rise (°F)	25-55	20-55	25-65	20-65	15-55
MEDIUM					
No. of Stages / No. of Burners (total)	2 / 4	2 / 4	2 / 5	2 / 5	2 / 8
Connection Size	3/4 in. NPT	3/4 in. NPT	3/4 in. NPT	3/4 in. NPT	3/4 in. NPT
Rollout Switch Opens / Closes (°F)	195 / 115	195 / 115	195 / 115	195 / 115	197 / 115
Temperature Rise (°F)	35-65	30-65	30-65	25-65	20-60
HIGH					
No. of Stages / No. of Burners (total)	2 / 5	2 / 5	2 / 5	2 / 5	2 / 10
Connection Size	3/4 in. NPT	3/4 in. NPT	3/4 in. NPT	3/4 in. NPT	3/4 in. NPT
Rollout Switch Opens / Closes (°F)	195 / 115	195 / 115	195 / 115	195 / 115	198 / 115
Temperature Rise (°F)	40-75	35-75	35-70	30-70	35-65
LIQUID PROPANE HEAT					
LOW					
No. of Stages / No. of Burners (total)	1 / 3	1 / 3	2 / 4	2 / 4	2 / 6
Connection Size	1/2 in. NPT	1/2 in. NPT	3/4 in. NPT	3/4 in. NPT	3/4 in. NPT
Rollout Switch Opens / Closes (°F)	195 / 115	195 / 115	195 / 115	195 / 115	196 / 115
Temperature Rise (°F)	25-55	20-55	25-65	20-65	15-55
MEDIUM					
No. of Stages / No. of Burners (total)	2 / 4	2 / 4	2 / 5	2 / 5	2 / 8
Connection Size	3/4 in. NPT	3/4 in. NPT	3/4 in. NPT	3/4 in. NPT	3/4 in. NPT
Rollout Switch Opens / Closes (°F)	195 / 115	195 / 115	195 / 115	195 / 115	197 / 115
Temperature Rise (°F)	35-65	30-65	30-65	25-65	20-60
HIGH					
No. of Stages / No. of Burners (total)	2 / 5	2 / 5	2 / 5	2 / 5	2 / 10
Connection Size	3/4 in. NPT	3/4 in. NPT	3/4 in. NPT	3/4 in. NPT	3/4 in. NPT
Rollout Switch Opens / Closes (°F)	195 / 115	195 / 115	195 / 115	195 / 115	198 / 115
Temperature Rise (°F)	40-75	35-75	35-70	30-70	35-65

Options and accessories

ITEM	FACTORY-INSTALLED OPTION	FIELD-INSTALLED ACCESSORY
GAS HEAT (RGF units only)		
Low, Medium, or High Gas Heat — Aluminized Heat Exchanger	X	
Low, Medium or High Gas Heat — Stainless Steel Heat Exchanger	X	
Propane Conversion Kit		X
High Altitude Conversion Kit		X
Flue Discharge Deflector		X
Flue Shield (090-150 sizes only)		X
ELECTRIC HEAT (RAF units only)		
Electric Resistance Heaters		X
Single Point Kits		X
CABINET		
Thru-the-Base Electrical or Gas-Line Connections		X
Hinged Access Panels	X	
4 in. Filter Rack (filters not included)		X
Disconnect Switch Bracket ^a		X
Supply Duct Cover ^a		X
COIL OPTIONS		
Cu/Cu Outdoor and/or Indoor Coils ^b	X	
Pre-coated Outdoor Coils	X	
Premium, E-Coated Outdoor and Indoor Coils	X	
HUMIDITY CONTROL		
Hot Gas Re-Heat Dehumidification System	X	
CONDENSER PROTECTION		
Condenser Coil Hail Guard (louvered design)	X	X
CONTROLS		
Thermostats, Temperature Sensors, And Subbases		X
Smoke Detector (supply and/or return air)	X	X
Horn Strobe Annunciator ^c		X
Time Guard Compressor Delay Control Circuit		X
Phase Monitor	X	X

ITEM	FACTORY-INSTALLED OPTION	FIELD-INSTALLED ACCESSORY
ECONOMIZERS AND OUTDOOR AIR DAMPERS		
EconomizerONE for Electromechanical Controls, complies with FDD (Standard and Ultra Low Leak damper models) ^d	X	X
Wi-Fi Stick for EconomizerONE (optional)		X
Motorized Two-Position Outdoor-Air Damper		X
Manual Outdoor-Air Damper (25% and 50%)		X
Barometric Relief ^e	X	X
Power Exhaust, Prop Design		X
Condensate Overflow Switch	X	X
ECONOMIZER SENSORS AND IAQ DEVICES		
Single Dry Bulb Temperature Sensors ^f	X	X
Differential Dry Bulb Temperature Sensors ^f		X
Differential Enthalpy Sensors ^f		X
CO ₂ Sensor (wall, duct, or unit mounted) ^f	X	X
INDOOR MOTOR AND DRIVE		
Multiple Motor and Drive Packages	X	
Fan Filter Status Switch	X	X
LOW AMBIENT CONTROLS		
Winter Start Kit ^g		X
Low Ambient Controller to 0°F (-18°C) ^h		X
POWER OPTIONS		
Convenience Outlet (powered)	X	
Convenience Outlet (unpowered)	X	
Convenience Outlet, 20 amp (unpowered)		X
Non-fused Disconnect ⁱ	X	
High SCCR Protection ^j	X	
ROOF CURBS		
Roof Curb 14 in. (356 mm)		X
Roof Curb 24 in. (610 mm)		X

NOTE(S):

- For Size 180 units only.
- Cu/Cu coils are only available with louvered hail guards.
- Requires a field-supplied 24V transformer for each application. See price pages for details.
- FDD (Fault Detection and Diagnostic) capability per California Title 24 section 120.2.
- Included with economizer.
- Sensors used to optimize economizer performance.
- See application data for assistance.
- Size 150 models operate down to 0°F (-18°C) standard, Low Ambient control is not available.
- Non-fused disconnect switch cannot be used when unit FLA electrical rating exceeds:
 - RGF/RAF090-150: 80 amps, all voltages.
 - RGF180: 100 amps 208/230V-3-60, 80 amps 460/575V-3-60
 - RAF180: 200 amps 208/230V-3-60, 100 amps 460/575V-3-60
- High SCCR (Short Circuit Current Rating) is not available on the following: units with Hot Gas Re-Heat system, low ambient controls, powered convenience outlet, phase loss monitor, non-fused disconnect, or 575-v. Not available on size 150 units due to control box constraints.

Options and accessories (cont)

Factory-installed options

Economizer (dry-bulb or enthalpy)

Economizers save money. They bring in fresh, outside air for ventilation; and provide cool, outside air to cool your building. This is the preferred method of low-ambient cooling. When coupled to CO₂ sensors, economizers can provide even more savings by coupling the ventilation air to only that amount required.

Economizers are available, installed and tested by the factory, with either enthalpy or dry-bulb temperature inputs. Additional sensors are available as accessories to optimize the economizers. Economizers include a barometric relief system to help equalize building pressures.

Economizers can be factory-installed or easily field-installed.

Unit mounted CO₂ sensor

The CO₂ sensor works with the economizer to intake only the correct amount of outside air for ventilation. As occupants fill your building, the CO₂ sensor detects their presence through increasing CO₂ levels, and opens the economizer appropriately. When the occupants leave, the CO₂ levels decrease, and the sensor appropriately closes the economizer. This intelligent control of the ventilation air, called demand controlled ventilation (DCV), reduces the overall load on the rooftop, saving money. It is also available as a field-installed accessory.

Smoke detector (supply and/or return air)

Trust the experts. Smoke detectors make your application safer and your job easier. Our smoke detectors immediately shut down the rooftop unit when smoke is detected. They are available, installed by the factory, for supply air, return air, or both.

Optional Hot Gas Re-Heat dehumidification system

The Hot Gas Re-Heat dehumidification system is an all-inclusive factory-installed option that can be ordered with any RGF/RAF090-180 rooftop unit.

This system expands the envelope of operation of RGF/RAF rooftop products to provide unprecedented flexibility to meet year round comfort conditions.

The Hot Gas Re-Heat dehumidification system has a unique dual operational mode setting. The Hot Gas Re-Heat system provides greater dehumidification of the occupied space by two modes of dehumidification operations in addition to its normal design cooling mode.

The RGF/RAF090-180 rooftop coupled with the Hot Gas Re-Heat system is capable of operating in normal design cooling mode, sub-cooling mode, and hot gas reheat mode. Normal design cooling mode is when the unit will operate under its normal sequence of operation by cycling compressors to maintain comfort conditions.

Sub-cooling mode will operate to satisfy part load type conditions when the space requires combined sensible and a higher proportion of latent load control. Hot Gas Reheat mode will operate when outdoor temperatures diminish and the need for latent capacity is required for sole

humidity control Hot Gas Reheat mode will provide neutral air for maximum dehumidification operation.

NOTE: Hot Gas Re-Heat system includes Low Ambient controller.

Hinged access panels

Allows access to unit's major components with specifically designed hinged access panels. Panels are filter, control box access indoor fan motor access.

Cu/Cu (indoor) coils

Copper fins and copper tubes are mechanically bonded to copper tubes and copper tube sheets. A polymer strip prevents coil assembly from contacting the sheet metal coil pan to minimize potential for galvanic corrosion between coil and pan.

E-coated (outdoor and indoor) coils

A flexible epoxy polymer coating uniformly applied to all coil surface areas without material bridging between fins. Coating process shall ensure complete coil encapsulation of tubes, fins and headers.

Condenser coil hail guard

These sleek, louvered panels protect the condenser coil from hail damage, foreign objects, and incidental contact. This can be purchased as a factory-installed option or as a field-installed accessory.

Pre-coated outdoor coils

A durable epoxy-phenolic coating to provide protection in mildly corrosive coastal environments. The coating minimizes galvanic action between dissimilar metals. Coating is applied to the aluminum fin stock prior to the fin stamping process to create an inert barrier between the aluminum fin and copper tube.

Stainless steel heat exchanger (RGF units only)

The stainless steel heat exchanger option provides the tubular heat exchanger be made out of a minimum 20 gauge type 409 stainless steel for applications where the mixed air to the heat exchanger is expected to drop below 45°F (7°C). Stainless steel may be specified on applications where the presence of airborne contaminants require its use (applications such as paper mills) or in area with very high outdoor humidity that may result in severe condensation in the heat exchanger during cooling operation.

Convenience outlet (powered or un-powered)

Reduce service and/or installation costs by including a convenience outlet in your specification. We install this service feature at our factory. Provides a convenient, 15 amp, 115v GFCI receptacle with "Wet in Use" cover. The "powered" option allows the installer to power the outlet from the line side of the disconnect or load side as required by code. The "unpowered" option is to be powered from a separate 115/120v power source.

The unpowered convenience outlet is available as a 15 amp factory-installed option or a 20 amp field-installed accessory.

Options and accessories (cont)

Non-fused disconnect

This OSHA-compliant, factory-installed, safety switch allows a service technician to locally secure power to the rooftop. When selecting a factory-installed non-fused disconnect, note they are sized for the unit as ordered from the factory. The sizing of these do not accommodate field-installed items such as power exhaust devices, etc. If field installing electric heat with factory-installed non-fused disconnect switch, a single point kit may or may not be required.

Condensate overflow switch

This sensor and related controller monitors the condensate level in the drain pan and shuts down compression operation when overflow conditions occur. It includes:

- Indicator light — solid red (more than 10 seconds on water contact — compressors disabled), blinking red (sensor disconnected)
- 10-second delay to break — eliminates nuisance trips from splashing or waves in pan (sensor needs 10 seconds of constant water contact before tripping)
- Disables the compressors operation when condensate plug is detected, but still allows fans to run for economizer.

Fan filter status switch and maintenance indicator

When the optional factory-installed filter maintenance indicator is used, a factory-installed differential pressure switch measures pressure drop across the outside air filter and activates a field-supplied dry contact indicator when the pressure differential exceeds the adjustable switch setpoint.

High Short Circuit Current Rating (SCCR) protection

This factory-installed option provides high short circuit current protection of 10 kA against high potential fault current situations for the compressors and all indoor and outdoor fan motors. (A standard unit comes with a 5 kA rating.)

This option is not available on 575-v models or models with a factory-installed Hot Gas Re-Heat system, low ambient controls, powered convenience outlet, phase loss monitor, or non-fused disconnect. High SCCR is not available on size 150 units due to control box constraints.

Field-installed accessories

Condenser coil hail guard

Sleek, louvered panels protect the condenser coil from hail damage, foreign objects, and incidental contact. This can be purchased as a factory-installed option or as a field-installed accessory.

Thru-the-base connections

Field-installed thru-the-base connections are necessary to ensure proper connection and seal when routing wire and piping through the rooftop's basepan and curb. These couplings eliminate roof penetration and should be

considered for gas lines, main power lines, as well as control power.

Differential enthalpy sensor

The differential enthalpy sensor is comprised of an outdoor and return air enthalpy sensors to provide differential enthalpy control. The sensor allows the unit to determine if outside air is suitable for free cooling.

Wall or duct mounted CO₂ sensor

The IAQ sensor shall be available in duct or wall mount. The sensor provides demand ventilation indoor air quality (IAQ) control.

Propane conversion kit (RGF units only)

Convert your gas heat rooftop from standard natural gas operation to propane using this field-installed kit.

High altitude conversion kit (RGF units only)

High altitudes have less oxygen, which affects the fuel/air mixture in heat exchangers. In order to maintain a proper fuel/air mixture, heat exchangers operating in altitudes above 2000 ft (610 m) require different orifices. To select the correct burner orifices or determine the heat capacity for a high altitude application, use either the selection software, or the unit's service manual. High altitudes have less oxygen, which means heat exchangers need less fuel. The new gas orifices in this field-installed kit make the necessary adjustment for high altitude applications. They restore the optimal fuel to air mixture and maintain healthy combustion on altitudes above 2000 ft (610 m).

NOTE: Typical natural gas heating value ranges from 975 to 1050 Btu/ft³ at sea level nationally. The heating value goes down approximately 1.7% per every thousand feet elevation. Standard factory orifices can typically be used up to 2000 ft (610 m) elevation without any operational issues.

Flue discharge deflector (RGF units only)

The flue discharge deflector is a useful accessory when flue gas recirculation is a concern. By venting the flue discharge upwards, the deflector minimizes the chance for a neighboring unit to intake the flue exhaust.

4 in. filter rack kit

The 4 in. filter rack accessory kit is designed to hold 4 in. MERV-8 or MERV-13 filters. Filters not included in kit.

Phase monitor protection

The Phase Monitor Control will monitor the sequence of three phase electrical system to provide a phase reversal protection; and monitor the three phase voltage inputs to provide a phase loss protection for the three phase device. It will work on either a Delta or Wye power connection.

Power exhaust with barometric relief

Superior internal building pressure control. This field-installed accessory may eliminate the need for costly, external pressure control fans.

Options and accessories (cont)

Winter start kit

The winter start kit extends the low ambient limit of your rooftop to 25°F (−4°C). The kit bypasses the low pressure switch, preventing nuisance tripping of the low pressure switch. Other low ambient precautions may still be prudent.

Low ambient controller

The low ambient controller is a head pressure controller kit that is designed to maintain the unit's condenser head pressure during periods of low ambient cooling operation. This device should be used as an alternative to economizer free cooling when economizer usage is either not appropriate or desired. The low ambient controller will either cycle the outdoor fan motors or operate them at reduced speed to maintain the unit operation, depending on the model. This controller allows cooling operation down to 0°F (−18°C) ambient conditions.

NOTE: 0°F (−18°C) is standard on size 150 models.

Roof curb (14 in./356 mm or 24 in./610 mm)

Full perimeter roof curb with exhaust capability provides separate air streams.

Filter status indicator accessory

Monitors static pressure across supply and exhaust filters and provides indication when filters become clogged.

Power exhaust

Superior internal building pressure control. This field-installed accessory may eliminate the need for costly, external pressure control fans.

Manual OA damper

Manual outdoor air dampers are an economical way to bring in ventilation air. The dampers are available in 25% and 50% versions.

Motorized two-position damper

The two-position, motorized outdoor air damper admits outside air. Using reliable, gear-driven technology, the 2-position damper opens to allow ventilation air and closes when the rooftop stops, stopping unwanted infiltration.

Electric heaters

A full-line of field-installed accessory heaters are offered. The heaters are very easy to use, install and are all pre-engineered and certified.

Time Guard II control circuit

This accessory protects your compressor by preventing short-cycling in the event of some other failure, prevents the compressor from restarting for 30 seconds after stopping.

Disconnect switch bracket

Provides a pre-engineered and sized mounting bracket for applications requiring a unit mounted fused and non-fused disconnect of greater than 100 amps. Bracket assures that no damage will occur to coils when mounting with screws and other fasteners (180 size only).

Wi-Fi Stick for EconomizerONE (optional)

The accessory Wi-Fi/WLAN stick can be connected to the EconomizerONE POL224 economizer controller via the USB host interface. The Wi-Fi stick enables a wireless connection to be made between a smartphone and the economizer controller via the Climatix™¹ mobile application for commissioning, troubleshooting, and maintenance operations. The Wi-Fi stick is required to utilize the mobile application but is not required for EconomizerONE setup and commissioning.

Climatix™ mobile application

The Climatix™ mobile application offers a best-in-class user interface and a simple step-by-step commissioning workflow using a mobile device. The user interface walks users through the setup of the controller and allows users to view the operating mode and parameters. Users can adjust setpoints, initiate damper tests, and save the final configuration as a favorite to expedite setup in the future.

The application is available on Android™¹ and Apple iOS®¹ platforms. The Wi-Fi stick for the EconomizerONE is required to join the Siemens-WiFi-Stick network and setup the controller on a smartphone.

NOTE: The Climatix app is not required to commission the EconomizerONE controller. The unit can be set up using the controller's on board button system.

1. Third-party trademarks and logos are the property of their respective owners.

Options and accessories (cont)

Options and Accessory Weights^a

OPTION / ACCESSORY NAME	RGF/RAF UNIT WEIGHT									
	090		102		120		150		180	
	lb	kg	lb	kg	lb	kg	lb	kg	lb	kg
Hot Gas Re-Heat System ^b	25	12	34	16	34	16	34	16	55	25
Power Exhaust	55	25	55	25	55	25	55	25	85	39
EconomizerONE	75	34	75	34	75	34	75	34	135	62
Two-Position Damper	58	26	58	26	58	26	58	26	65	29
Manual Damper	18	8	18	8	18	8	18	8	25	11
High Gas Heat (RGF units only)	81	37	81	37	86	39	86	39	117	53
Hail Guard (louvered)	17	8	17	8	17	8	17	8	44	20
Cu/Cu Condenser Coil	85	39	85	39	100	46	150	68	180	82
Cu/Cu Evaporator Coil	50	23	100	46	100	46	100	46	120	55
Roof Curb (14 in. curb)	143	65	143	65	143	65	143	65	180	82
Roof Curb (24 in. curb)	245	112	245	112	245	112	245	112	255	116
CO ₂ Sensor	2	1	2	1	2	1	2	1	2	1
Flue Discharge Deflector	7	3	7	3	7	3	7	3	7	3
Optional Indoor Motor ^c	30	14	30	14	30	14	0	0	0	0
Low Ambient Controller	9	4	9	4	9	4	9	4	9	4
Winter Start Kit	5	2	5	2	5	2	5	2	5	2
Return Air Smoke Detector	7	3	7	3	7	3	7	3	7	3
Supply Air Smoke Detector	7	3	7	3	7	3	7	3	7	3
Fan Filter Switch	2	1	2	1	2	1	2	1	2	1
Non-Fused Disconnect	15	7	15	7	15	7	15	7	15	7
Powered Convenience Outlet ^d	36	16	36	16	36	16	36	16	36	16
Unpowered Convenience Outlet	4	2	4	2	4	2	4	2	4	2
Enthalpy Sensor	2	1	2	1	2	1	2	1	2	1
Differential Enthalpy Sensor	3	1	3	1	3	1	3	1	3	1

NOTE(S):

- a. Where multiple variations are available, the heaviest combination is listed.
- b. For Hot Gas Re-Heat system, add Low Ambient controller weight.
- c. Add the Optional Indoor Motor weight to the weight of the base unit.
- d. Weight includes convenience outlet and convenience outlet transformer.

RGF090-120 Base Unit Dimensions

- NOTES:
1. DIMENSIONS ARE IN INCHES. DIMENSIONS IN () ARE IN MILLIMETERS.
 2. CENTER OF GRAVITY
 3. DIRECTION OF AIR FLOW
 4. ALL VIEW DRAWN USING 3RD ANGLE

UNIT	OUTDOOR COIL TYPE	J	K	H
RGF-090	RTPF	41 1/4 [1046]	33 3/4 [857]	15 7/8 [403]
RGF-102	RTPF	49 3/8 [1253]	36 3/8 [925]	15 7/8 [403]
RGF-120	RTPF	49 3/8 [1253]	36 3/8 [925]	15 7/8 [403]

RTPF - ROUND TUBE, PLATE FIN (COPPER/ALUM)



THIS DOCUMENT IS THE PROPERTY OF CARRIER CORPORATION AND IS DELIVERED UPON THE EXPRESS CONDITION THAT THE CONTENTS WILL NOT BE DISCLOSED OR USED WITHOUT WRITTEN CONSENT.

SUBMISSION OF THESE DRAWINGS OR DOCUMENTS DOES NOT CONSTITUTE PAST PERFORMANCE OR ACCEPTANCE OF CONTRACT.

CONNECTION SIZES	
A	1 3/8" [35] DIA FIELD POWER SUPPLY HOLE
B	2 1/2" [64] DIA POWER SUPPLY KNOCKOUT
C	1 3/4" [51] DIA GAUGE ACCESS PLUG
D	7/8" [22] DIA FIELD CONTROL WIRING HOLE
E	3/4"-14 NPT CONDENSATE DRAIN
F	1/2"-14 NPT GAS CONNECTION 3/4"-14 NPT GAS CONNECTION
G	2" [51] DIA POWER SUPPLY KNOCK-OUT

THRU-THE-BASE CHART (FIELD INST)

THESE HOLES REQUIRED FOR USE WITH ACCY KITS:
CRBTMPR002A01: GAS THRU CURB
CRBTMPR004A01: GAS THRU BASEPAN

	THREADED CONDUIT SIZE	WIRE USE	REQ'D HOLE SIZES (MAX.)
W	1/2"	ACC.	7/8" [22.2]
X	1/2"	24V	7/8" [22.2]
Y	1 1/4" (002, 004)	POWER	1 3/4" [44.4]
Z *	(004) 3/4" FPT	GAS	1 3/4" [44.4]

* (002) PROVIDES 3/4" FPT THRU CURB FLANGE & FITTING. HOLE SIZE: 2" [50.8]

THRU-THE-BASE CHART (FIOP)

FOR "THRU-THE-BASEPAN" FACTORY OPTION, FITTINGS FOR ONLY X, Y, & Z ARE PROVIDED. **

FOR BELOW LISTED MODELS, A FIELD SUPPLIED 1/2" ADAPTER IS REQUIRED BETWEEN BASE PAN FITTING AND GAS VALVE:
RGV-090, RGV-102

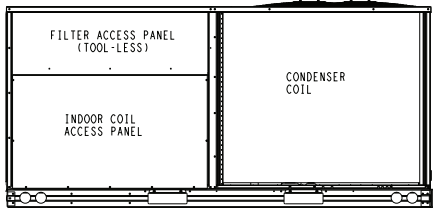

BACK

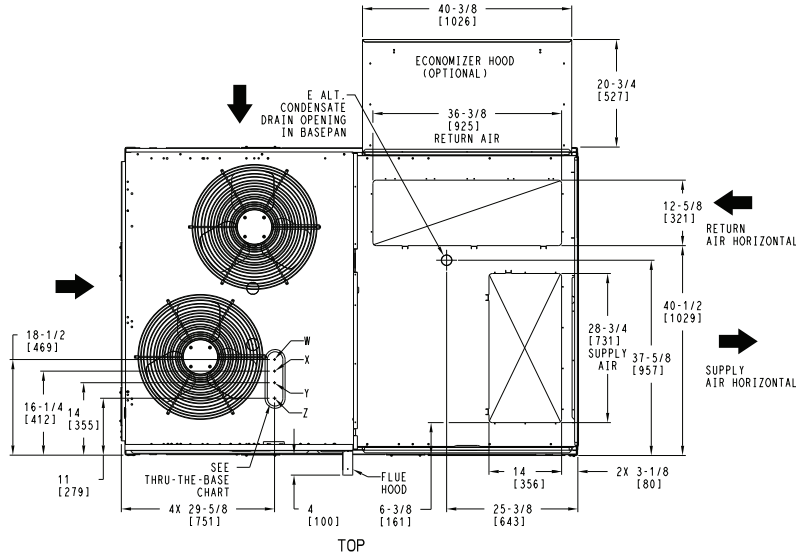

TOP

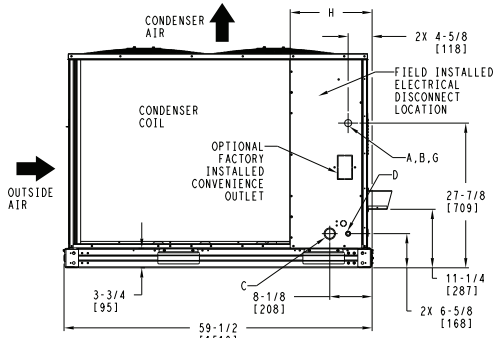

LEFT

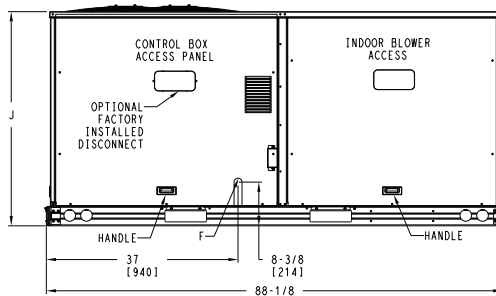

FRONT

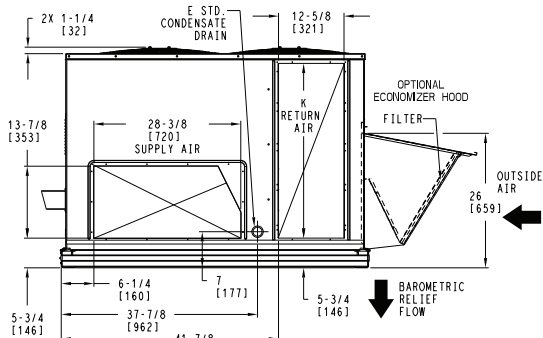

RIGHT

ITC CLASSIFICATION	SHEET	DATE	SUPERCEDES	RGF 090-120 SINGLE ZONE ELECTRICAL COOLING WITH GAS HEAT	48TM009322	REV
U.S. ECCN:NSR	1 OF 3	8/8/23	-			-

RGF090-120 Base Unit Dimensions (cont)

UNIT	OUTDOOR COIL TYPE	STD. UNIT WEIGHT ***		CORNER WEIGHT (A)		CORNER WEIGHT (B)		CORNER WEIGHT (C)		CORNER WEIGHT (D)		C.G.			
		LBS.	KG.	LBS.	KG.	LBS.	KG.	LBS.	KG.	LBS.	KG.	X	Y	Z	
RGF-090	RTPF	787	357	181	82	150	68	207	94	249	113	40	1/2 [1016]	34 1/2 [876]	19 3/8 [492]
RGF-102	RTPF	868	394	197	89	160	73	229	104	282	128	39 1/2 [1003]	35 [889]	18 5/8 [473]	
RGF-120	RTPF	878	398	213	97	175	80	221	100	268	121	39 7/8 [1013]	33 1/4 [841]	18 1/2 [470]	

*** STANDARD UNIT WEIGHT IS WITH LOW GAS HEAT AND WITHOUT PACKAGING. FOR OTHER OPTIONS AND ACCESSORIES, REFER TO THE PRODUCT DATA CATALOG.

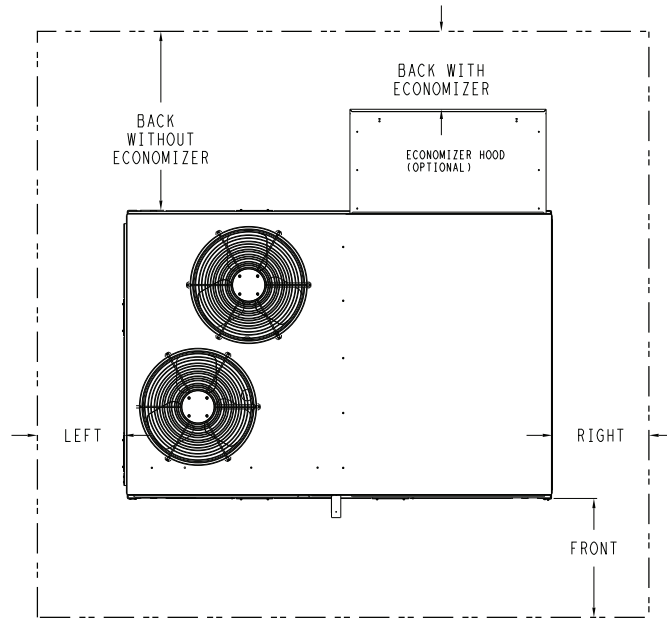
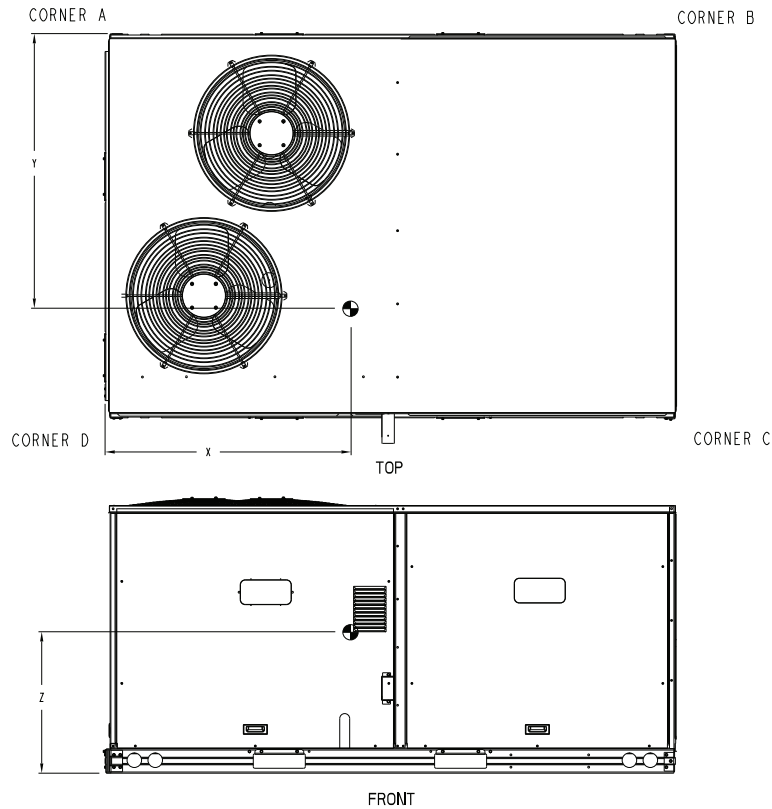

NOTE:

- FOR ALL MINIMUM CLEARANCES LOCAL CODES OR JURISDICTIONS MAY PREVAIL.

SURFACE	CLEARANCE		OPERATING CLEARANCE
	SERVICE WITH: CONDUCTIVE BARRIER	SERVICE WITH: NONCONDUCTIVE BARRIER	
FRONT	48 [1219mm]	36 [914mm]	18 [457mm]
LEFT	48 [1219mm]	42 [1067mm]	18 [457mm]
BACK W/O ECON	48 [1219mm]	42 [1067mm]	18 [457mm]
BACK W/ECON	36 [914mm]	36 [914mm]	18 [457mm]
RIGHT	36 [914mm]	36 [914mm]	18 [457mm]
TOP	72 [1829mm]	72 [1829mm]	72 [1829mm]

ITC CLASSIFICATION	SHEET	DATE	SUPERCEDES	RGF 090-120 SINGLE ZONE ELECTRICAL COOLING WITH GAS HEAT	48TMO09322	REV
U.S. ECCN:NSR	2 OF 3	8/8/23	-			-



THIS DOCUMENT IS THE PROPERTY OF CARRIER CORPORATION AND IS DELIVERED UPON THE EXPRESS CONDITION THAT THE CONTENTS WILL NOT BE DISCLOSED OR USED WITHOUT WRITTEN CONSENT.

SUBMISSION OF THESE DRAWINGS OR DOCUMENTS DOES NOT CONSTITUTE PAST PERFORMANCE OR ACCEPTANCE OF CONTRACT.

RGF090-120 Base Unit Dimensions (cont)

IGP THIS DOCUMENT IS THE PROPERTY OF CARRIER CORPORATION AND IS DELIVERED UPON THE EXPRESS CONDITION THAT THE CONTENTS WILL NOT BE DISCLOSED OR USED WITHOUT WRITTEN CONSENT. SUBMISSION OF THESE DRAWINGS OR DOCUMENTS DOES NOT CONSTITUTE PART PERFORMANCE OR ACCEPTANCE OF CONTRACT.

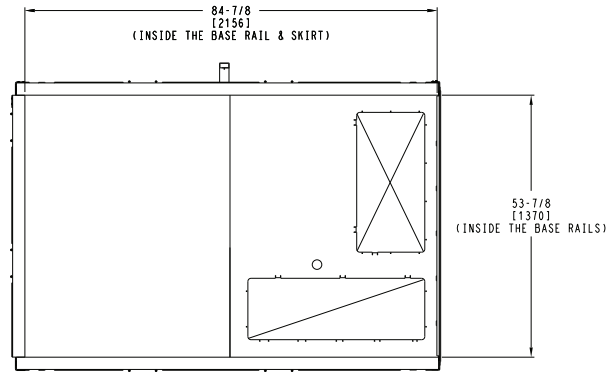
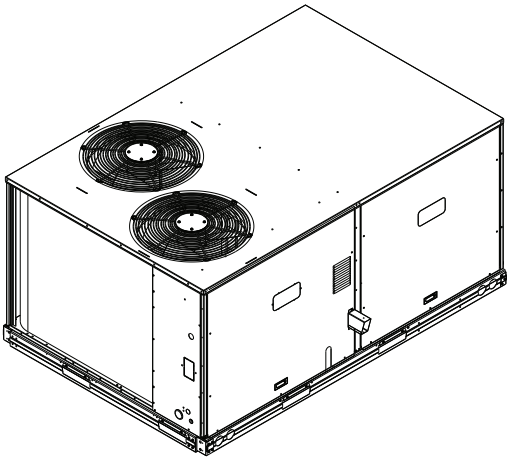

INSIDE BASERAIL DIMENSIONS
BOTTOM

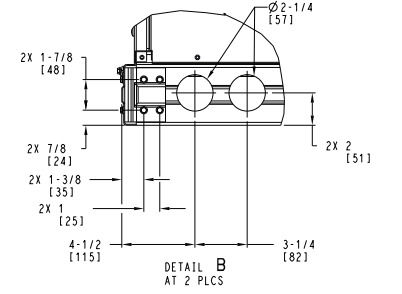

DETAIL B
AT 2 PLCS

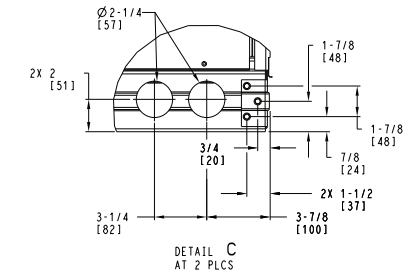

DETAIL C
AT 2 PLCS

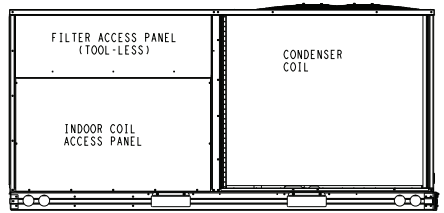

BACK

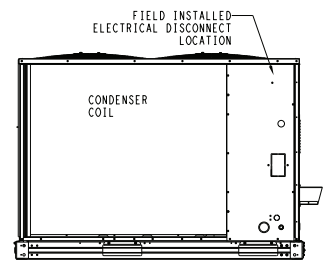

LEFT

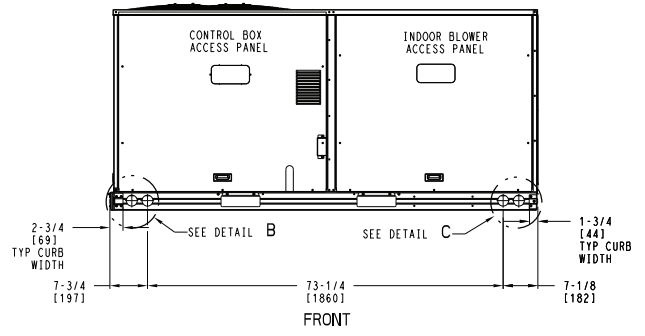

FRONT

ITC CLASSIFICATION U.S. ECCN: NSR	SHEET 3 OF 3	DATE 8/8/23	SUPERCEDES -	RGF 090-120 SINGLE ZONE ELECTRICAL COOLING WITH GAS HEAT	48TM009322	REV -
--------------------------------------	-----------------	----------------	-----------------	--	------------	----------

RGF150 Base Unit Dimensions

- NOTES:
1. DIMENSIONS ARE IN INCHES, DIMENSIONS IN [] ARE IN MILLIMETERS.
 2. CENTER OF GRAVITY
 3. DIRECTION OF AIR FLOW
 4. ALL VIEW DRAWN USING 3RD ANGLE

UNIT	OUTDOOR COIL TYPE	H
RGF-150	RTPF	15 7/8 [403]
RTPF - ROUND TUBE, PLATE FIN (COPPER/ALUM)		



THIS DOCUMENT IS THE PROPERTY OF CARRIER CORPORATION AND IS DELIVERED UPON THE EXPRESS CONDITION THAT THE CONTENTS WILL NOT BE DISCLOSED OR USED WITHOUT WRITTEN CONSENT.

SUBMISSION OF THESE DRAWINGS OR DOCUMENTS DOES NOT CONSTITUTE PART PERFORMANCE OR ACCEPTANCE OF CONTRACT.

CONNECTION SIZES	
A	1 3/8" [35] DIA. FIELD POWER SUPPLY HOLE
B	2 1/2" [64] DIA. POWER SUPPLY KNOCKOUT
C	1 3/4" [51] DIA. GAUGE ACCESS PLUG
D	7/8" [22] DIA. FIELD CONTROL WIRING HOLE
E	3/4"-14 NPT CONDENSATE DRAIN
F	3/4"-14 NPT GAS CONNECTION
G	2" [51] DIA. POWER SUPPLY KNOCK-OUT

THRU-THE-BASE CHART THESE HOLES REQUIRED FOR USE CRBTMPWRO2A01,004A01			
	THREADED CONDUIT SIZE	WIRE USE	REQ'D HOLE SIZES (MAX.)
W	1/2"	ACC.	7/8" [22.2]
X	1/2"	24V	7/8" [22.2]
Y	1 1/4" (002,004)	POWER	1 3/4" [44.4]
Z*	(004) 3/4" FPT	GAS	1 5/8" [41.3]
FOR "THRU-THE-BASEPAN" FACTORY OPTION, FITTINGS FOR ONLY X, Y, & Z ARE PROVIDED			
* (002) PROVIDES 3/4" FPT THRU CURB FLANGE & FITTING.			

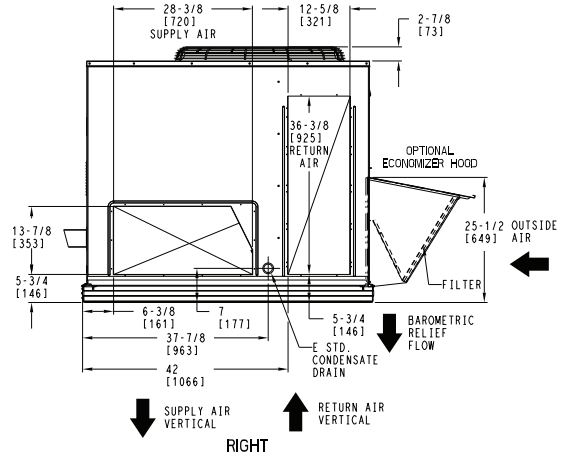
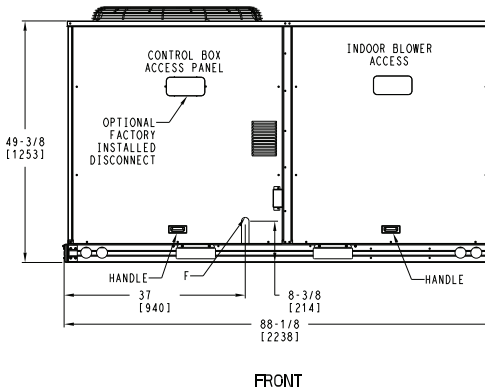
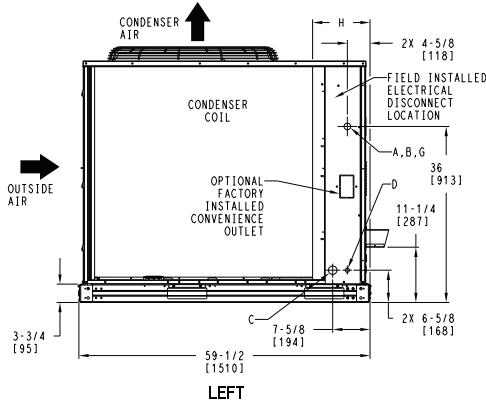
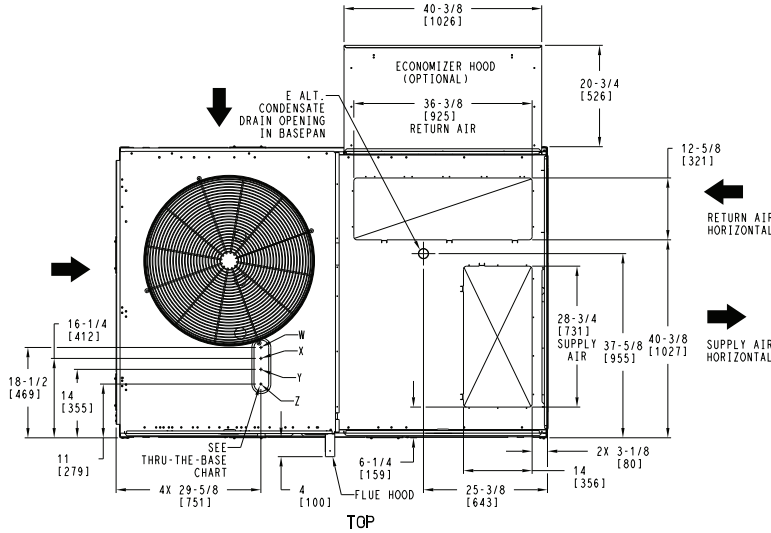
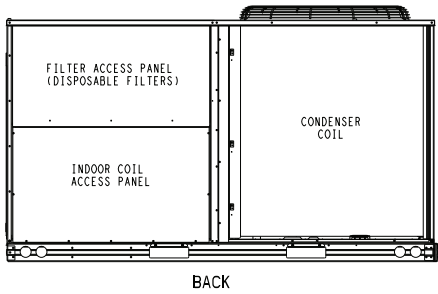

ITC CLASSIFICATION	SHEET	DATE	SUPERCEDES	RGF-150 SINGLE ZONE ELECTRICAL COOLING WITH GAS HEAT	48TM009980	REV
U.S. ECCN:NSR	1 OF 3	08/02/24	-			-

RGF150 Base Unit Dimensions (cont)

UNIT	OUTDOOR COIL TYPE	STD. UNIT WEIGHT***		CORNER WEIGHT (A)		CORNER WEIGHT (B)		CORNER WEIGHT (C)		CORNER WEIGHT (D)		C.G.		
		LBS.	KG.	LBS.	KG.	LBS.	KG.	LBS.	KG.	LBS.	KG.	X	Y	Z
RGF-150	RTPF	1041	472	243	110	195	88	269	122	335	152	39 1/4 [997]	34 1/2 [876]	21 7/8 [556]
RTPF - ROUND TUBE, PLATE FIN (COPPER/ALUM)														

ICP THIS DOCUMENT IS THE PROPERTY OF CARRIER CORPORATION AND IS DELIVERED UPON THE EXPRESS CONDITION THAT THE CONTENTS WILL NOT BE DISCLOSED OR USED WITHOUT WRITTEN CONSENT. SUBMISSION OF THESE DRAWINGS OR DOCUMENTS DOES NOT CONSTITUTE PART PERFORMANCE OR ACCEPTANCE OF CONTRACT.

*** STANDARD UNIT WEIGHT IS WITH LOW GAS HEAT AND WITHOUT PACKAGING. FOR OTHER OPTIONS AND ACCESSORIES, REFER TO THE PRODUCT DATA CATALOG.

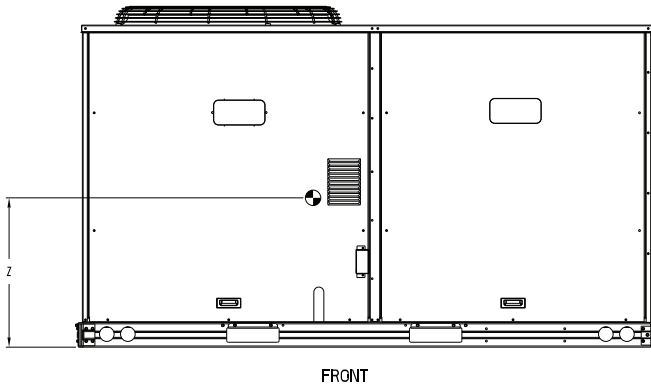
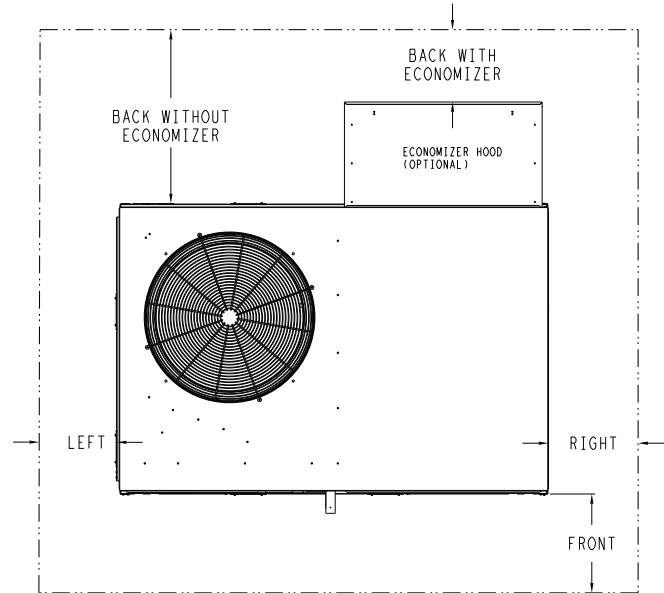
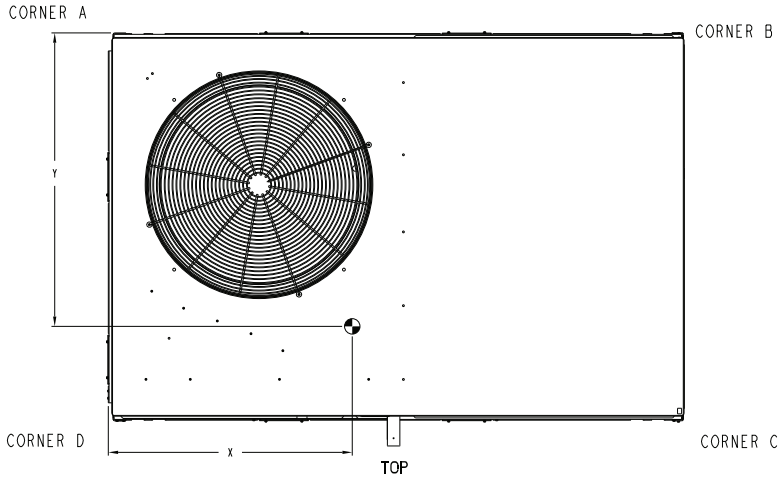

NOTE:
1. FOR ALL MINIMUM CLEARANCES LOCAL CODES OR JURISDICTIONS MAY PREVAIL.

SURFACE	CLEARANCE		
	SERVICE WITH: CONDUCTIVE BARRIER	SERVICE WITH NONCONDUCTIVE BARRIER	OPERATING CLEARANCE
FRONT	48 [1219mm]	36 [914mm]	18 [457mm]
LEFT	48 [1219mm]	42 [1067mm]	18 [457mm]
BACK W/O ECON	48 [1219mm]	42 [1067mm]	18 [457mm]
BACK W/ECON	36 [914mm]	36 [914mm]	18 [457mm]
RIGHT	36 [914mm]	36 [914mm]	18 [457mm]
TOP	72 [1829mm]	72 [1829mm]	72 [1829mm]

ITC CLASSIFICATION U.S. ECCN:NSR	SHEET 2 OF 3	DATE 08/02/24	SUPERCEDES -	RGF-150 SINGLE ZONE ELECTRICAL COOLING WITH GAS HEAT	48TM009980	REV -
-------------------------------------	-----------------	------------------	-----------------	--	------------	----------

RGF150 Base Unit Dimensions (cont)



THIS DOCUMENT IS THE PROPERTY OF CARRIER CORPORATION AND IS DELIVERED UPON THE EXPRESS CONDITION THAT THE CONTENTS WILL NOT BE DISCLOSED OR USED WITHOUT WRITTEN CONSENT. SUBMISSION OF THESE DRAWINGS OR DOCUMENTS DOES NOT CONSTITUTE PART PERFORMANCE OR ACCEPTANCE OF CONTRACT.

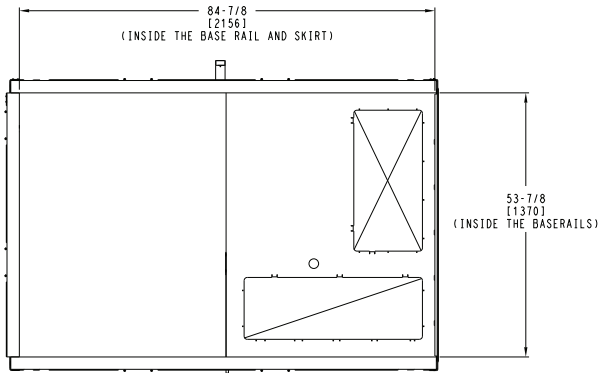
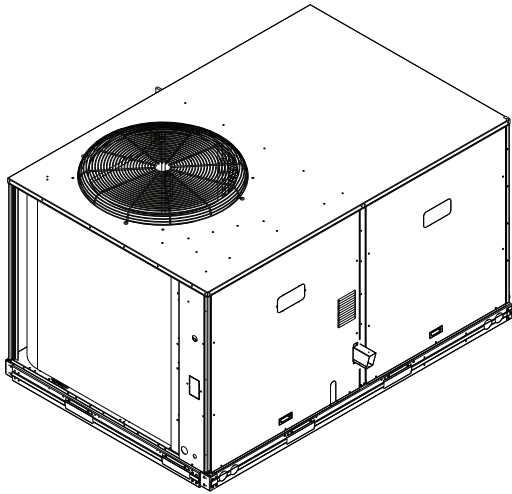

INSIDE BASERAIL DIMENSIONS
BOTTOM

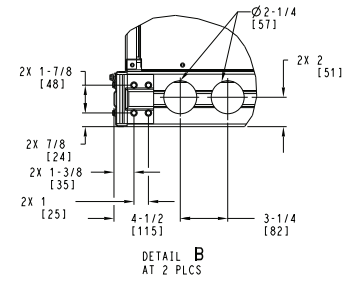

DETAIL B
AT 2 PLCS

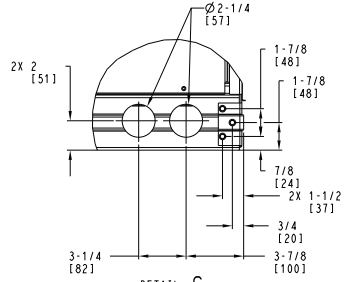

DETAIL C
AT 2 PLCS

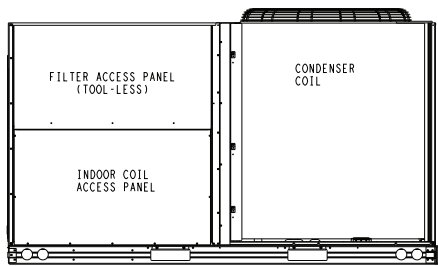

BACK

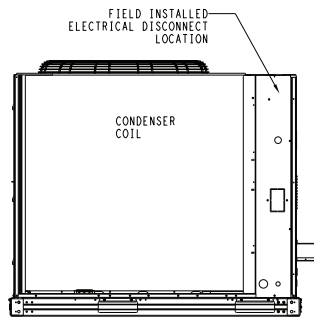

LEFT

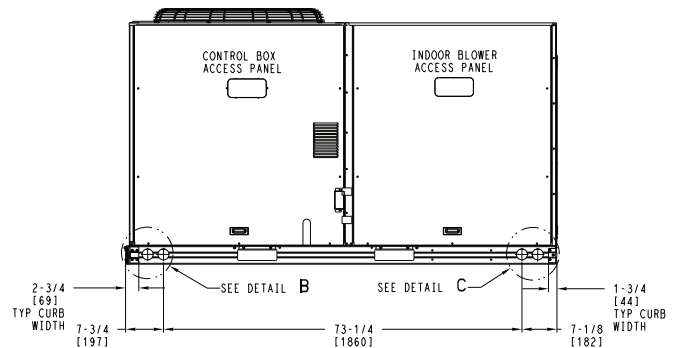

FRONT

ITC CLASSIFICATION U.S. ECCN:NSR	SHEET 3 OF 3	DATE 08/02/24	SUPERCEDES -	RGF-150 SINGLE ZONE ELECTRICAL COOLING WITH GAS HEAT	48TM009980	REV -
-------------------------------------	-----------------	------------------	-----------------	---	------------	----------

RGF180 Base Unit Dimensions

- NOTES:
1. DIMENSIONS ARE IN INCHES. DIMENSIONS IN [] ARE IN MILLIMETERS.
 2. CENTER OF GRAVITY
 3. DIRECTION OF AIR FLOW



THIS DOCUMENT IS THE PROPERTY OF CARRIER CORPORATION AND IS DELIVERED UPON THE EXPRESS CONDITION THAT THE CONTENTS WILL NOT BE DISCLOSED OR USED WITHOUT WRITTEN CONSENT.

SUBMISSION OF THESE DRAWINGS OR DOCUMENTS DOES NOT CONSTITUTE PAST PERFORMANCE OR ACCEPTANCE OF CONTRACT.

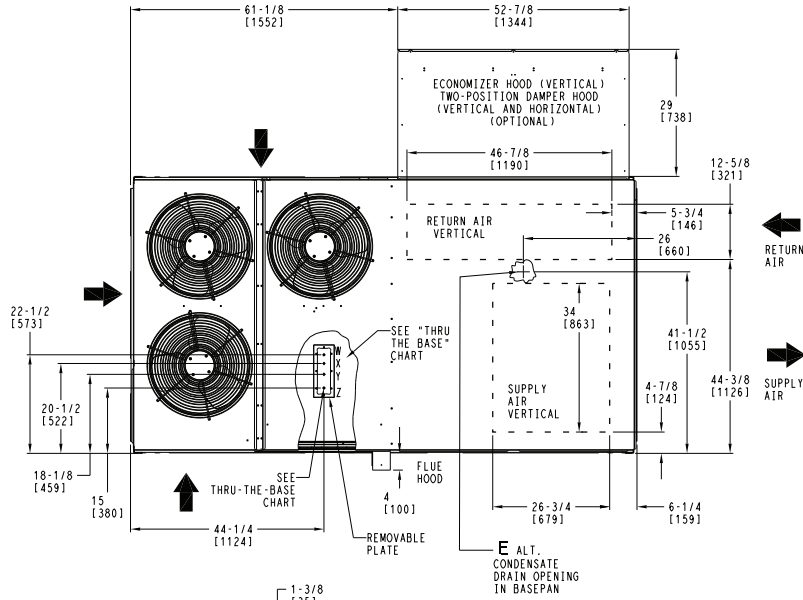
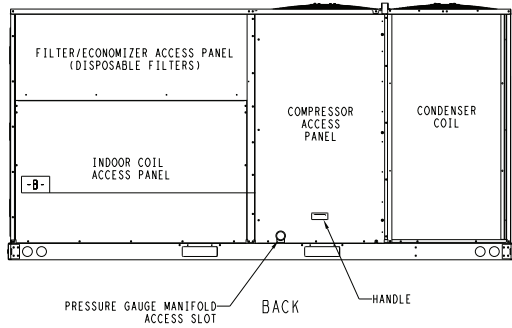

CONNECTION SIZES	
B	2 1/2" [64] DIA POWER SUPPLY HOLE
D	7/8" [22] DIA FIELD CONTROL WIRING HOLE
E	3/4"-14 NPT CONDENSATE DRAIN
F	7/8" [22] DIA FIELD CONVENIENCE OUTLET HOLE
G	3/4"-14 NPT GAS CONNECTION

THRU-THE-BASE CHART THESE HOLES REQUIRED FOR USE CRBTMPW005A00,006A00,007A00				
ACCESSORY NO.	THREADED CONDUIT SIZE	WIRE USE	REQ'D HOLE SIZES (MAX.)	
005	W	1/2" ACC.	7/8" [22.2]	
	X	1/2" 24V	7/8" [22.2]	
	Y	1 1/4" POWER	1 1/2" [38.1]	
006	Z	3/4" PIPE GAS	1 3/4" [44.5]	
	W	1/2" ACC.	7/8" [22.2]	
	X	1/2" 24V	7/8" [22.2]	
007	Y	2" POWER	2 1/2" [63.5]	
	Z	3/4" PIPE GAS	1 3/4" [44.5]	
	FOR "THRU-THE-BASE PAN" FACTORY OPTION, FITTINGS FOR X & Y ARE PROVIDED AS SPECIFIED ON "006".			

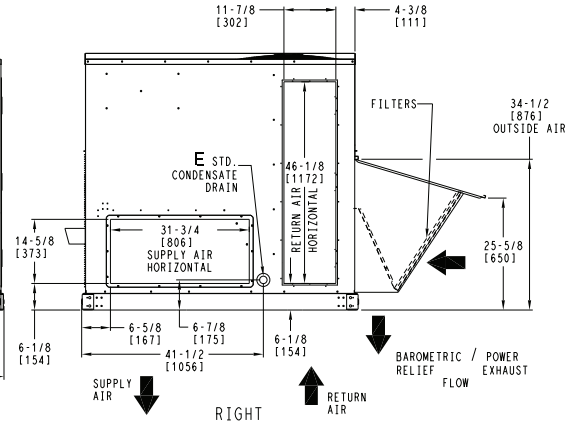
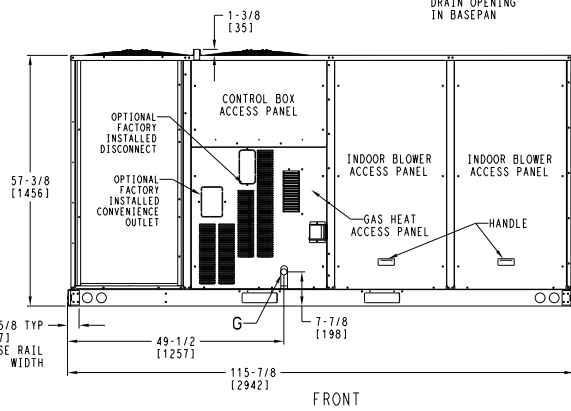
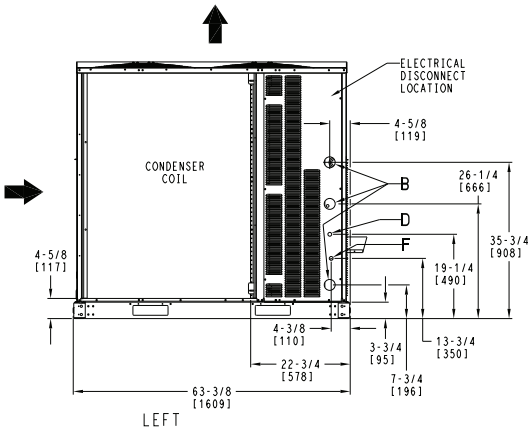

ITC CLASSIFICATION	SHEET	DATE	SUPERCEDES	RGF 180 SINGLE ZONE ELECTRICAL COOLING WITH GAS HEAT	50TM003164	REV
U.S. ECCN:NSR	1 OF 2	8/10/23	-			-

RGF180 Base Unit Dimensions (cont)

UNIT	STD UNIT WEIGHT		CORNER WEIGHT (A)		CORNER WEIGHT (B)		CORNER WEIGHT (C)		CORNER WEIGHT (D)		C.G.		
	LBS.	KG.	LBS.	KG.	LBS.	KG.	LBS.	KG.	LBS.	KG.	X	Y	Z
RGF-180	1408	639	373	169	341	155	332	150	362	164	55 3/8 [1407]	31 1/4 [794]	21 1/8 [537]

STANDARD UNIT WEIGHT IS WITH LOW HEAT & WITHOUT PACKAGING. FOR OPTIONS & ACCESSORIES, REFER TO THE PRODUCT DATA CATALOG.

IGP THIS DOCUMENT IS THE PROPERTY OF CARRIER CORPORATION AND IS DELIVERED UPON THE EXPRESS CONDITION THAT THE CONTENTS WILL NOT BE DISCLOSED OR USED WITHOUT WRITTEN CONSENT. SUBMISSION OF THESE DRAWINGS OR DOCUMENTS DOES NOT CONSTITUTE PAST PERFORMANCE OR ACCEPTANCE OF CONTRACT.

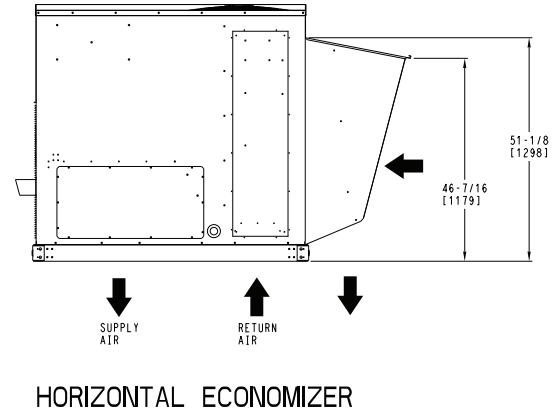
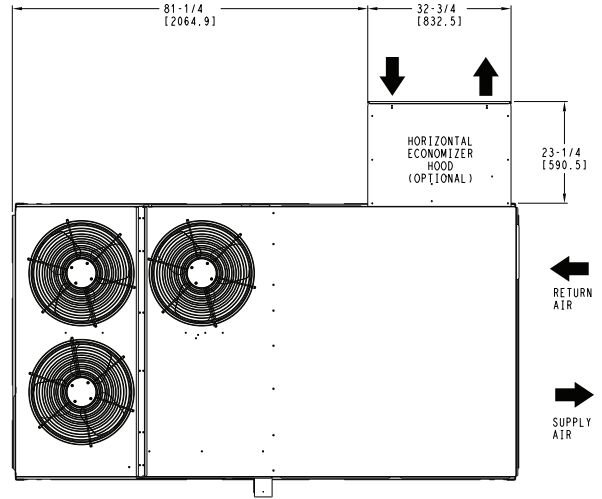
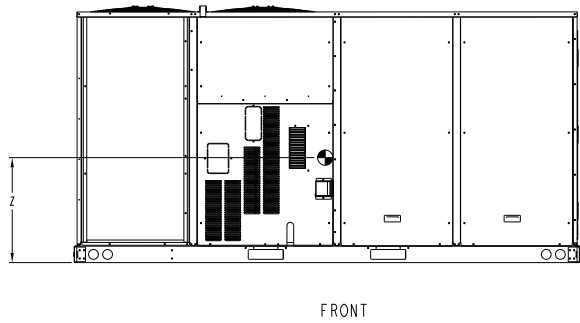
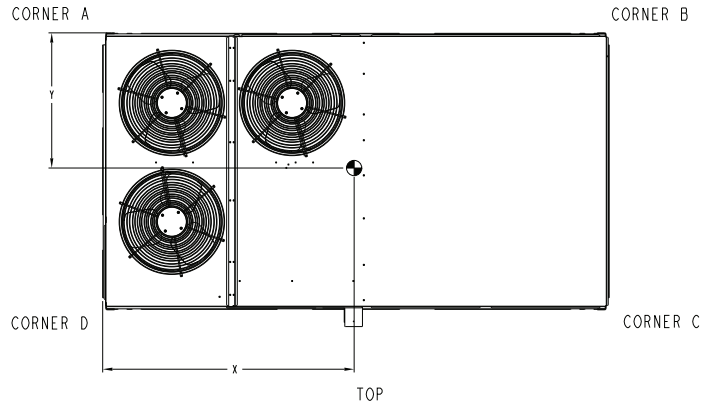

ITC CLASSIFICATION U.S. ECCN:NSR	SHEET 2 OF 2	DATE 8/10/23	SUPERCEDES -	RGF 180 SINGLE ZONE ELECTRICAL COOLING WITH GAS HEAT	50TM003164	REV -
-------------------------------------	-----------------	-----------------	-----------------	---	------------	----------

Base unit dimensions (cont)

RGF180 Base Unit Dimensions — Clearance

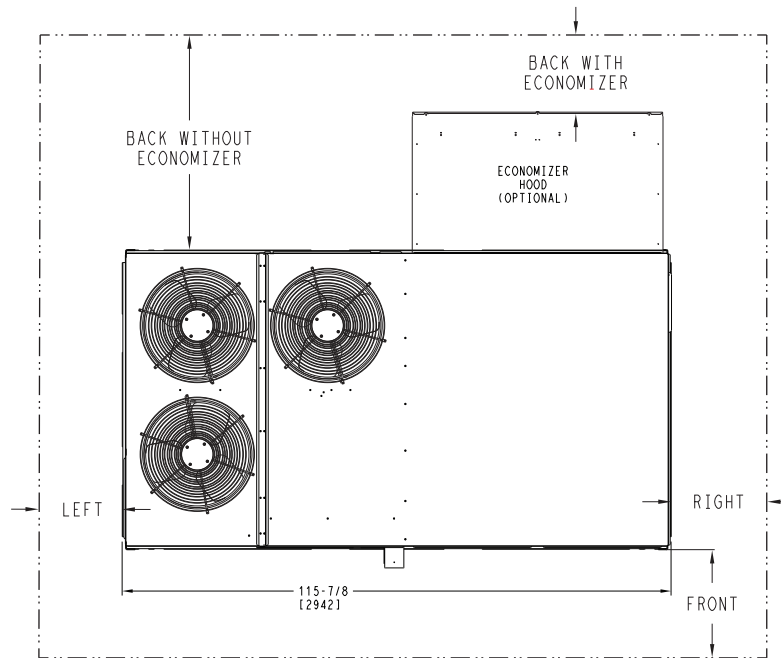

CLEARANCE^{a,b}

SURFACE	Service with Conductive Barrier	Service with Non-conductive Barrier	Operating Clearance
FRONT	48 in. (1219 mm)	36 in. (914 mm)	18 in. (457 mm)
LEFT	48 in. (1219 mm)	42 in. (1067 mm)	18 in. (457 mm)
BACK WITHOUT ECONOMIZER	48 in. (1219 mm)	42 in. (1067 mm)	18 in. (457 mm)
BACK WITH ECONOMIZER	36 in. (914 mm)	36 in. (914 mm)	18 in. (457 mm)
RIGHT	36 in. (914 mm)	36 in. (914 mm)	18 in. (457 mm)
TOP	72 in. (1829 mm)	72 in. (1829 mm)	72 in. (1829 mm)

NOTE(S):

- a. For all minimum clearances local codes or jurisdictions may prevail.
- b. See page 19 for RGF090-120 clearances. See page 22 for RGF150 clearances.

RAF090-120 Base Unit Dimensions

- NOTES:
1. DIMENSIONS ARE IN INCHES, DIMENSIONS IN () ARE IN MILLIMETERS.
 2. CENTER OF GRAVITY
 3. DIRECTION OF AIR FLOW
 4. ALL VIEW DRAWN USING 3RD ANGLE

UNIT	OUTDOOR COIL TYPE	J	K	H
RAF-090	RTPF	41 1/4 [1048]	33 3/4 [857]	15 7/8 [403]
RAF-102	RTPF	49 3/8 [1253]	36 3/8 [925]	15 7/8 [403]
RAF-120	RTPF	49 3/8 [1253]	36 3/8 [925]	15 7/8 [403]

RTPF - ROUND TUBE, PLATE FIN (COPPER/ALUM)



THIS DOCUMENT IS THE PROPERTY OF CARRIER CORPORATION AND IS DELIVERED UPON THE EXPRESS CONDITION THAT THE CONTENTS WILL NOT BE DISCLOSED OR USED WITHOUT WRITTEN CONSENT.

SUBMISSION OF THESE DRAWINGS OR DOCUMENTS DOES NOT CONSTITUTE PART PERFORMANCE OR ACCEPTANCE OF CONTRACT.

CONNECTION SIZES	
A	1 3/8" [35] DIA FIELD POWER SUPPLY HOLE
B	2 1/2" [64] DIA POWER SUPPLY KNOCKOUT
C	1 3/4" [51] DIA GAUGE ACCESS PLUG
D	7/8" [22] DIA FIELD CONTROL WIRING HOLE
E	3/4"-14 NPT CONDENSATE DRAIN
G	2" [51] DIA POWER SUPPLY KNOCK-OUT

THRU-THE-BASE CHART (FIELD INST)			
THESE HOLES REQUIRED FOR USE WITH ACCY KITS: CRBTMPWR002A01			
	THREADED CONDUIT SIZE	WIRE USE	REQ'D HOLE SIZES (MAX.)
W	1/2"	ACC.	7/8" [22.2]
X	1/2"	24V	7/8" [22.2]
Y	1 1/4" (002)	POWER	1 3/4" [44.4]

THRU-THE-BASE CHART (FIOP)
 FOR "THRU-THE-BASEPAN" FACTORY OPTION, FITTINGS FOR ONLY X & Y ARE PROVIDED: (1) 1/2" & (1) 1 1/4" ELECTRICAL FITTINGS.

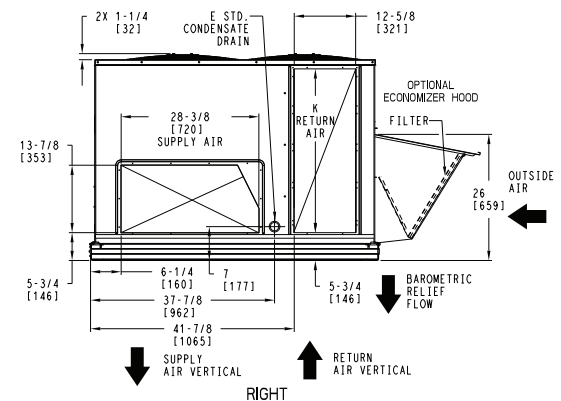
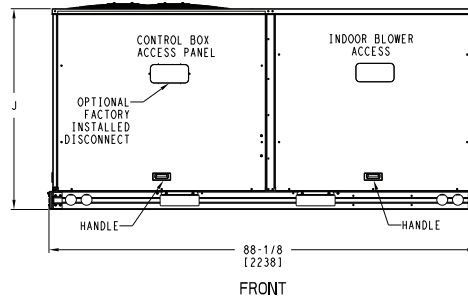
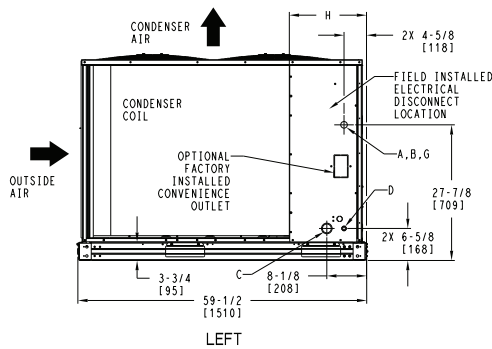
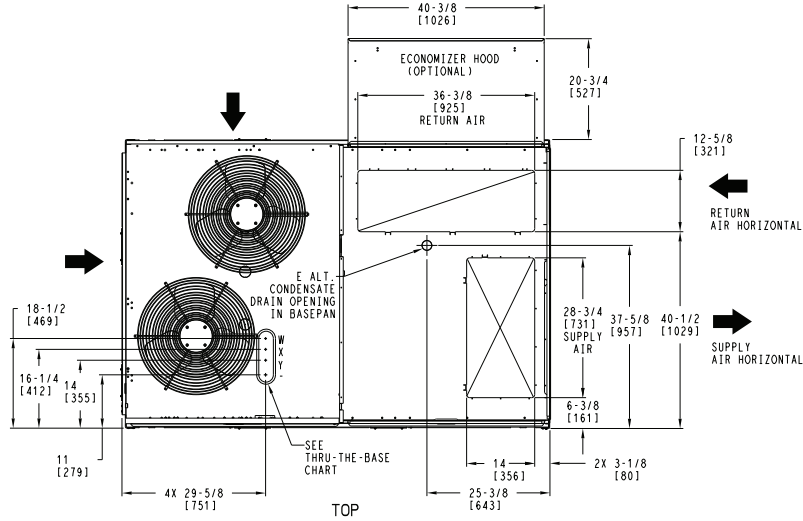
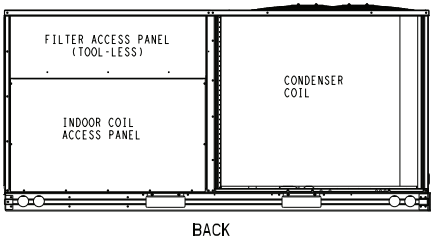

ITC CLASSIFICATION	SHEET	DATE	SUPERCEDES	RAF 090-120 SINGLE ZONE ELECTRICAL COOLING WITH ELECTRIC HEAT	48TM009325	REV
U.S. ECCN:NSR	1 OF 3	8/8/23	-			-

RAF090-120 Base Unit Dimensions (cont)

UNIT	OUTDOOR COIL TYPE	STD. UNIT WEIGHT ***		CORNER WEIGHT (A)		CORNER WEIGHT (B)		CORNER WEIGHT (C)		CORNER WEIGHT (D)		C. G.		
		LBS.	KG.	LBS.	KG.	LBS.	KG.	LBS.	KG.	LBS.	KG.	X	Y	Z
RAF-090	RTPF	743	337	170	77	142	64	196	89	235	107	40 [1016]	34 1/2 [876]	20 [508]
RAF-102	RTPF	805	365	201	91	157	71	196	89	251	114	38 5/8 [981]	33 [838]	19 1/8 [486]
RAF-120	RTPF	815	370	204	92	159	72	198	90	254	115	38 5/8 [981]	33 [838]	19 1/8 [486]

*** STANDARD UNIT WEIGHT IS WITHOUT ELECTRIC HEAT AND WITHOUT PACKAGING. FOR OTHER OPTIONS AND ACCESSORIES, REFER TO THE PRODUCT DATA CATALOG.



THIS DOCUMENT IS THE PROPERTY OF CARRIER CORPORATION AND IS DELIVERED UPON THE EXPRESS CONDITION THAT THE CONTENTS WILL NOT BE DISCLOSED OR USED WITHOUT WRITTEN CONSENT.

SUBMISSION OF THESE DRAWINGS OR DOCUMENTS DOES NOT CONSTITUTE PART PERFORMANCE OR ACCEPTANCE OF CONTRACT.

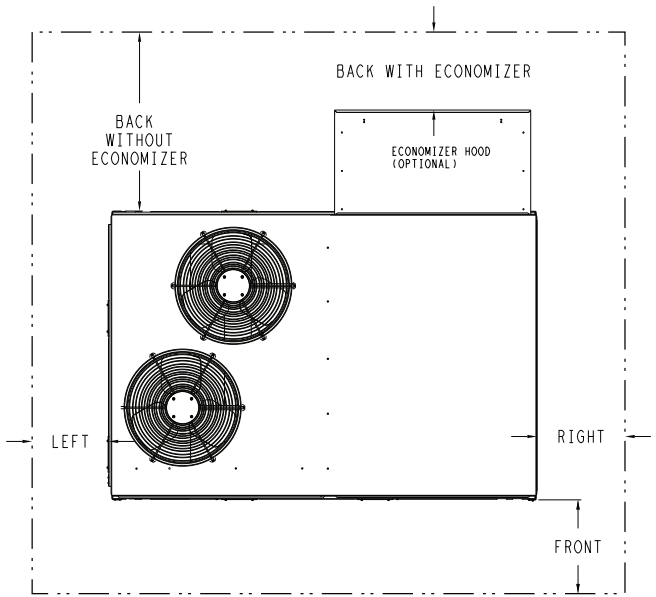
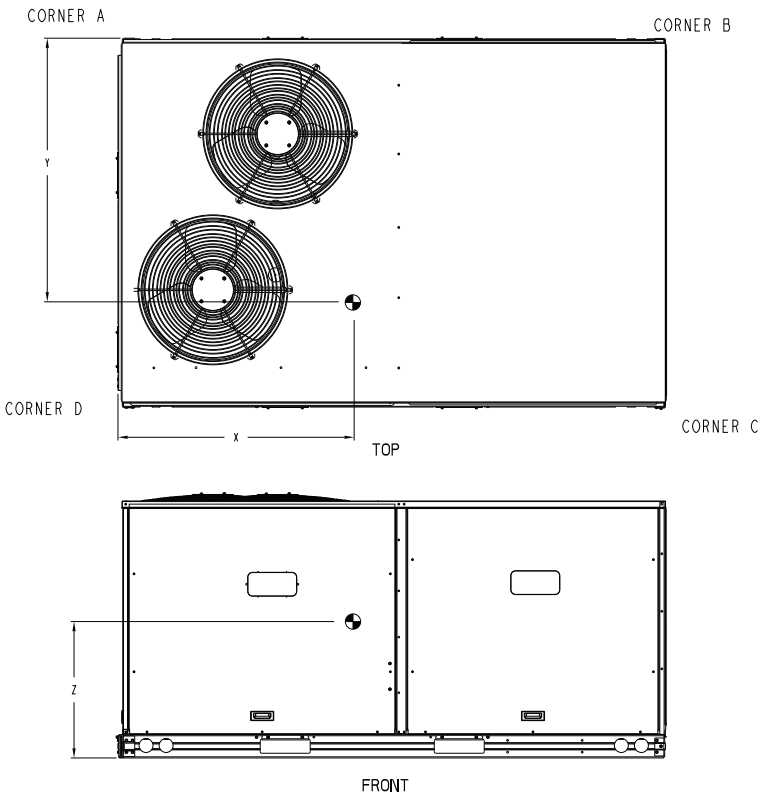

NOTE:
1. FOR ALL MINIMUM CLEARANCES LOCAL CODES OR JURISDICTIONS MAY PREVAIL.

	CLEARANCE		OPERATING CLEARANCE
	SERVICE WITH: CONDUCTIVE BARRIER	SERVICE WITH: NONCONDUCTIVE BARRIER	
FRONT	48 [1219mm]	36 [914mm]	18 [457mm]
LEFT	48 [1219mm]	42 [1067mm]	18 [457mm]
BACK W/O ECON	48 [1219mm]	42 [1067mm]	18 [457mm]
BACK W/ECON	36 [914mm]	36 [914mm]	18 [457mm]
RIGHT	36 [914mm]	36 [914mm]	18 [457mm]
TOP	72 [1829mm]	72 [1829mm]	72 [1829mm]

ITC CLASSIFICATION U.S. ECCN:NSR	SHEET 2 OF 3	DATE 8/8/23	SUPERCEDES -	RAF 090-120 SINGLE ZONE ELECTRICAL COOLING WITH ELECTRIC HEAT	48TM009325	REV -
-------------------------------------	-----------------	----------------	-----------------	---	------------	----------

RAF090-120 Base Unit Dimensions (cont)



THIS DOCUMENT IS THE PROPERTY OF CARRIER CORPORATION AND IS DELIVERED UPON THE EXPRESS CONDITION THAT THE CONTENTS WILL NOT BE DISCLOSED OR USED WITHOUT WRITTEN CONSENT.

SUBMISSION OF THESE DRAWINGS OR DOCUMENTS DOES NOT CONSTITUTE PAST PERFORMANCE OR ACCEPTANCE OF CONTRACT.

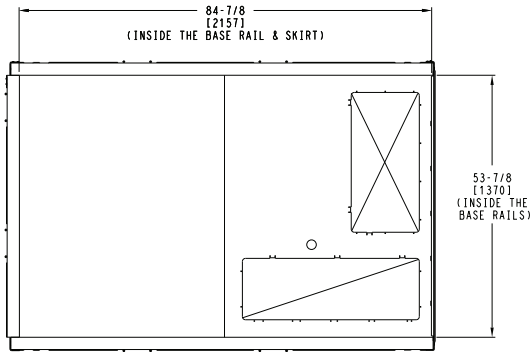
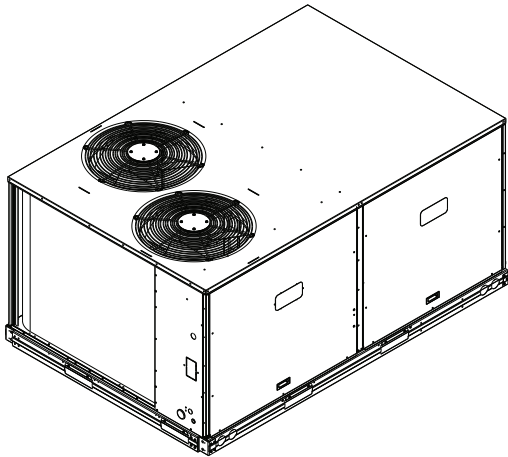

INSIDE BASERAIL DIMENSIONS
BOTTOM

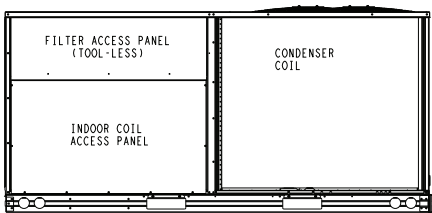
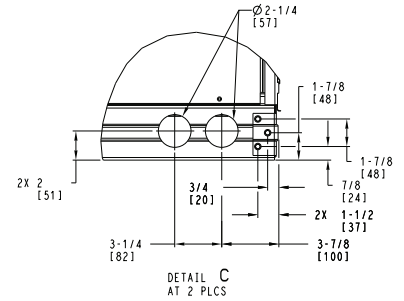
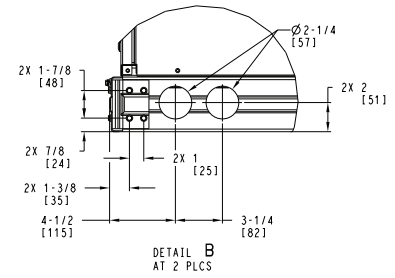

BACK

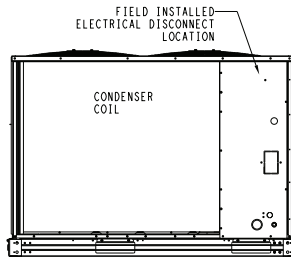

LEFT

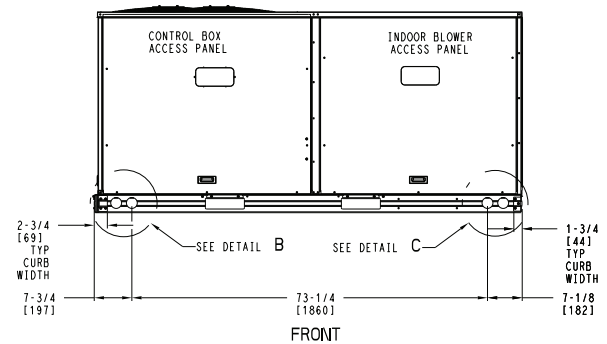

FRONT

ITC CLASSIFICATION U.S. ECCN:NSR	SHEET 3 OF 3	DATE 8/8/23	SUPERCEDES -	RAF 090-120 SINGLE ZONE ELECTRICAL COOLING WITH ELECTRIC HEAT	48TM009325	REV -
-------------------------------------	-----------------	----------------	-----------------	---	------------	----------

RAF150 Base Unit Dimensions

- NOTES:
1. DIMENSIONS ARE IN INCHES, DIMENSIONS IN [] ARE IN MILLIMETERS.
 2. CENTER OF GRAVITY
 3. DIRECTION OF AIR FLOW
 4. ALL VIEW DRAWN USING 3RD ANGLE



THIS DOCUMENT IS THE PROPERTY OF CARRIER CORPORATION AND IS DELIVERED UPON THE EXPRESS CONDITION THAT THE CONTENTS WILL NOT BE DISCLOSED OR USED WITHOUT WRITTEN CONSENT.

SUBMISSION OF THESE DRAWINGS OR DOCUMENTS DOES NOT CONSTITUTE PART PERFORMANCE OR ACCEPTANCE OF CONTRACT.

UNIT	OUTDOOR COIL TYPE	H
RAF-150	RTPF	15 7/8 [403]
RTPF - ROUND TUBE, PLATE FIN (COPPER/ALUM)		

CONNECTION SIZES	
A	1 3/8" [35] DIA FIELD POWER SUPPLY HOLE
B	2 1/2" [64] DIA POWER SUPPLY KNOCKOUT
C	1 3/4" [51] DIA GAUGE ACCESS PLUG
D	7/8" [22] DIA FIELD CONTROL WIRING HOLE
E	3/4" -14 NPT CONDENSATE DRAIN
G	2" [51] DIA POWER SUPPLY KNOCK-OUT

THRU-THE-BASE CHART THESE HOLES REQUIRED FOR USE CRBTMPWR002A01			
	THREADED CONDUIT SIZE	WIRE USE	REQ'D HOLE SIZES (MAX.)
W	1/2"	ACC.	7/8" [22.2]
X	1/2"	24V	7/8" [22.2]
Y	1 1/4" [002]	POWER	1 3/4" [44.4]

FOR "THRU-THE-BASEPAN" FACTORY OPTION, FITTINGS FOR ONLY X & Y ARE PROVIDED

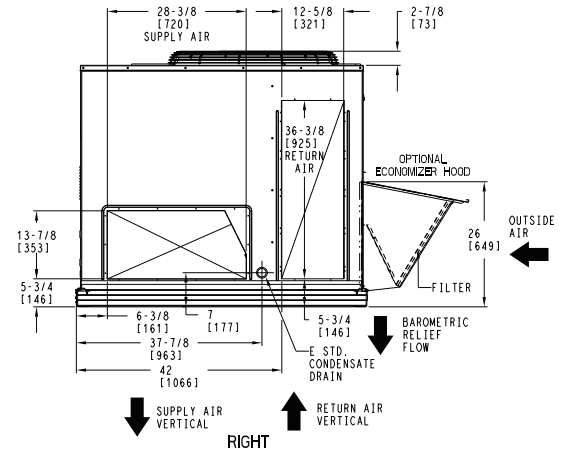
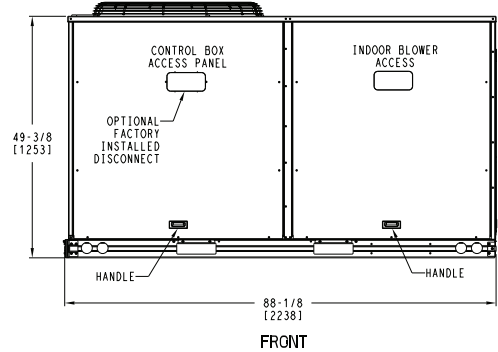
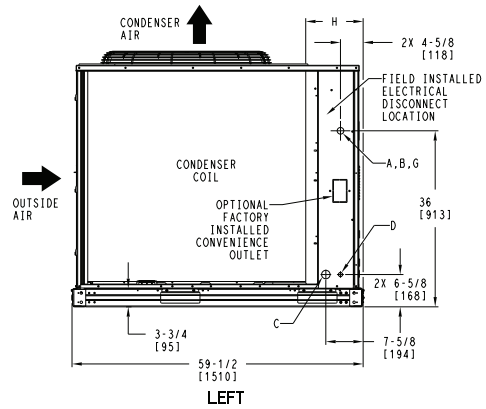
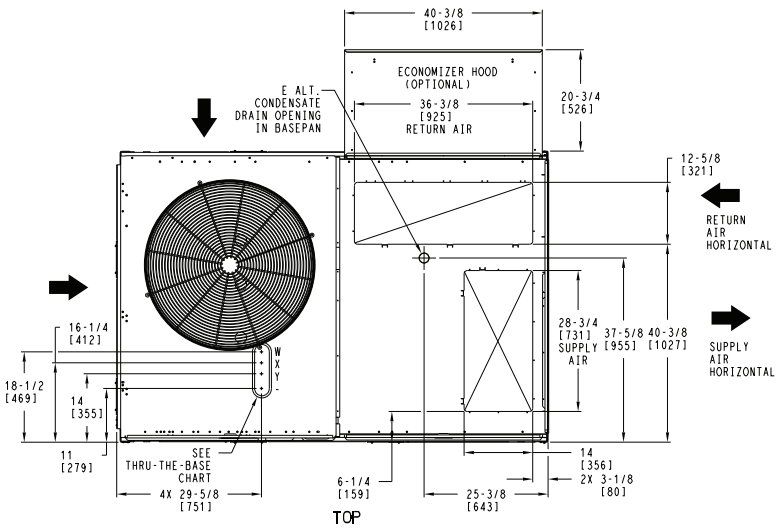
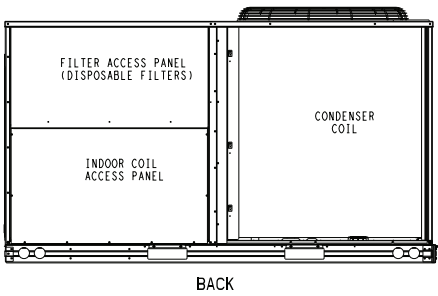

ITC CLASSIFICATION	SHEET	DATE	SUPERCEDES	RAF-150 SINGLE ZONE ELECTRICAL COOLING WITH ELECTRIC HEAT	48TM009983	REV
U.S. ECCN:NSR	1 OF 3	08/02/24	-			-

RAF150 Base Unit Dimensions (cont)

UNIT	OUTDOOR COIL TYPE	STD. UNIT WEIGHT***		CORNER WEIGHT (A)		CORNER WEIGHT (B)		CORNER WEIGHT (C)		CORNER WEIGHT (D)		C.G.					
		LBS.	KG.	LBS.	KG.	LBS.	KG.	LBS.	KG.	LBS.	KG.	X	Y	Z			
RAF-150	RTPF	978	444	245	111	191	87	238	108	305	138	38 5/8	[981]	33	[838]	20 1/2	[521]

RTPF - ROUND TUBE, PLATE FIN (COPPER/ALUM)

*** STANDARD UNIT WEIGHT IS WITHOUT ELECTRIC HEAT AND WITHOUT PACKAGING. FOR OTHER OPTIONS AND ACCESSORIES, REFER TO THE PRODUCT DATA CATALOG.

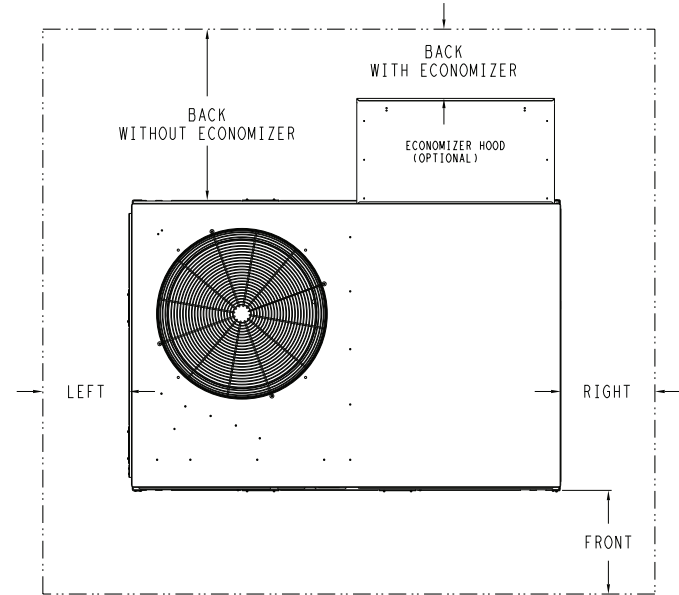
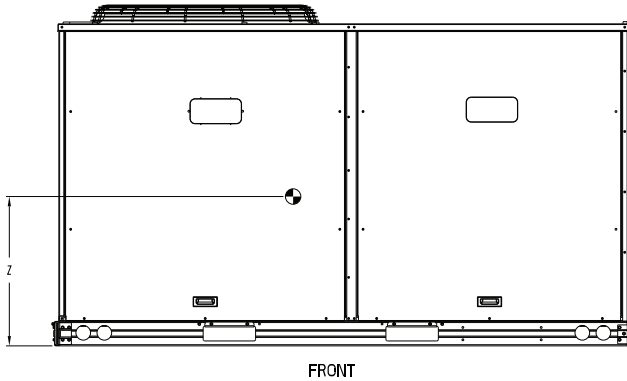
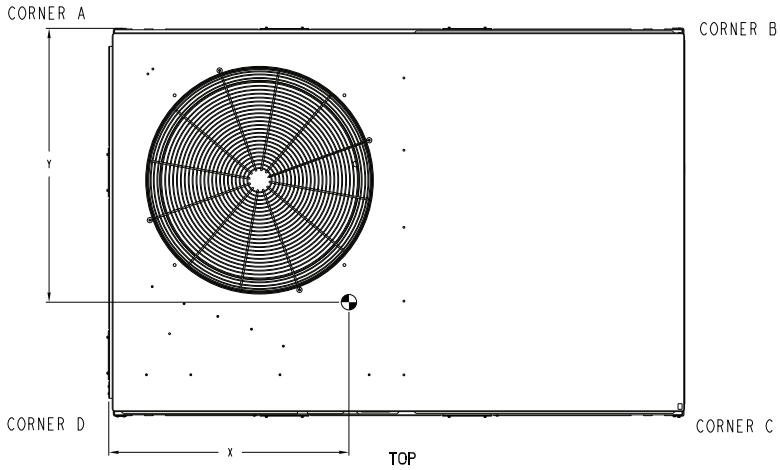

NOTE:

1. FOR ALL MINIMUM CLEARANCES LOCAL CODES OR JURISDICTIONS MAY PREVAIL.

SURFACE	SERVICE WITH:		OPERATING CLEARANCE
	CONDUCTIVE BARRIER	NONCONDUCTIVE BARRIER	
FRONT	48 [1219mm]	36 [914mm]	18 [457mm]
LEFT	48 [1219mm]	42 [1067mm]	18 [457mm]
BACK W/O ECON	48 [1219mm]	42 [1067mm]	18 [457mm]
BACK W/ECON	36 [914mm]	36 [914mm]	18 [457mm]
RIGHT	36 [914mm]	36 [914mm]	18 [457mm]
TOP	72 [1829mm]	72 [1829mm]	72 [1829mm]

ITC CLASSIFICATION U.S. ECCN:NSR	SHEET 2 OF 3	DATE 08/02/24	SUPERCEDES -	RAF-150 SINGLE ZONE ELECTRICAL COOLING WITH ELECTRIC HEAT	48TM009983	REV -
-------------------------------------	-----------------	------------------	-----------------	---	------------	----------



THIS DOCUMENT IS THE PROPERTY OF CARRIER CORPORATION AND IS DELIVERED UPON THE EXPRESS CONDITION THAT THE CONTENTS WILL NOT BE DISCLOSED OR USED WITHOUT WRITTEN CONSENT.

SUBMISSION OF THESE DRAWINGS OR DOCUMENTS DOES NOT CONSTITUTE PART PERFORMANCE OR ACCEPTANCE OF CONTRACT.

RAF150 Base Unit Dimensions (cont)

ICP THIS DOCUMENT IS THE PROPERTY OF CARRIER CORPORATION AND IS DELIVERED UPON THE EXPRESS CONDITION THAT THE CONTENTS WILL NOT BE DISCLOSED OR USED WITHOUT WRITTEN CONSENT. SUBMISSION OF THESE DRAWINGS OR DOCUMENTS DOES NOT CONSTITUTE PART PERFORMANCE OR ACCEPTANCE OF CONTRACT.

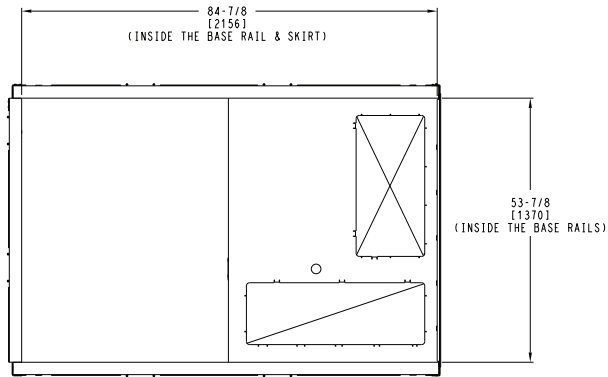
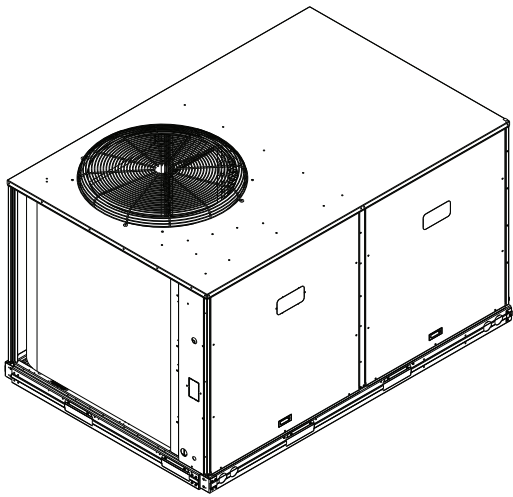

INSIDE BASERAIL DIMENSIONS
BOTTOM

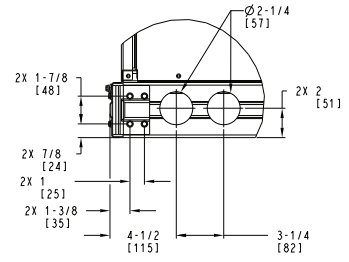

DETAIL B
TYP 2 PLCS

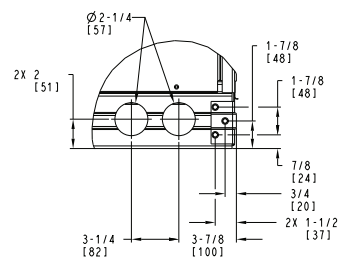

DETAIL C
TYP 2 PLCS

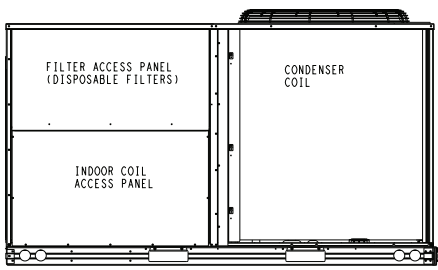

BACK

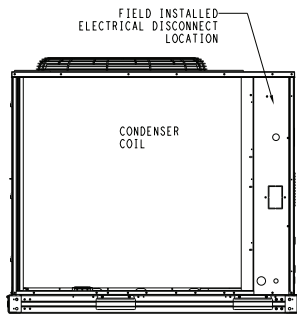

LEFT

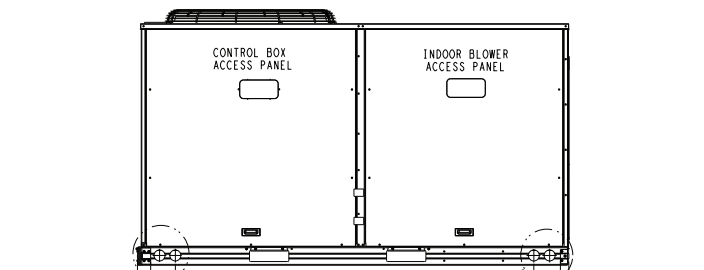

FRONT

ITC CLASSIFICATION	SHEET	DATE	SUPERCEDES	RAF-150 SINGLE ZONE ELECTRICAL COOLING WITH ELECTRIC HEAT	48TM009983	REV
U.S. ECCN:NSR	3 OF 3	08/02/24	-			-

RAF180 Base Unit Dimensions

- NOTES:
1. DIMENSIONS ARE IN INCHES. DIMENSIONS IN [] ARE IN MILLIMETERS.
 2. CENTER OF GRAVITY
 3. DIRECTION OF AIR FLOW



THIS DOCUMENT IS THE PROPERTY OF CARRIER CORPORATION AND IS DELIVERED UPON THE EXPRESS CONDITION THAT THE CONTENTS WILL NOT BE DISCLOSED OR USED WITHOUT WRITTEN CONSENT.

SUBMISSION OF THESE DRAWINGS OR DOCUMENTS DOES NOT CONSTITUTE PART PERFORMANCE OR ACCEPTANCE OF CONTRACT.

CONNECTION SIZES	
B	2 1/2" [64] DIA POWER SUPPLY HOLE
D	7/8" [22] DIA FIELD CONTROL WIRING HOLE
E	3/4"-14 NPT CONDENSATE DRAIN
F	7/8" [22] DIA FIELD CONVENIENCE OUTLET HOLE

THRU-THE-BASE CHART THESE HOLES REQUIRED FOR USE CRBTMPR005A00, 006A00, 007A00			
ACCESSORY NO.	THREADED CONDUIT SIZE	WIRE USE	REQ'D HOLE SIZES (MAX.)
005	W 1/2"	ACC.	7/8" [22.2]
	X 1/2"	24V	7/8" [22.2]
	Y 1 1/4"	POWER	1 1/2" [38.1]
006	W 1/2"	ACC.	7/8" [22.2]
	X 1/2"	24V	7/8" [22.2]
	Y 1 1/2"	POWER	2" [50.8]
007	W 1/2"	ACC.	7/8" [22.2]
	X 1/2"	24V	7/8" [22.2]
	Y 2"	POWER	2 1/2" [63.5]

FOR "THRU-THE-BASEPAN" FACTORY OPTION, FITTINGS FOR X & Y ARE PROVIDED AS SPECIFIED ON "006".

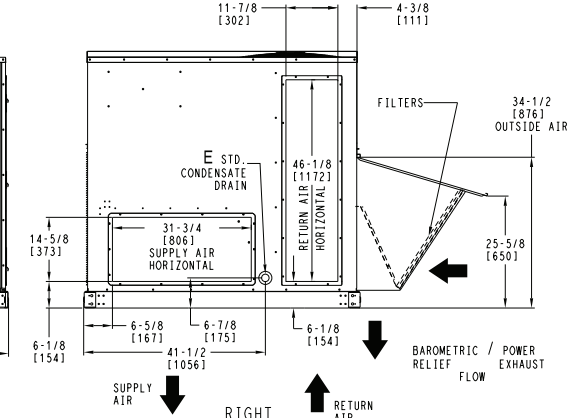
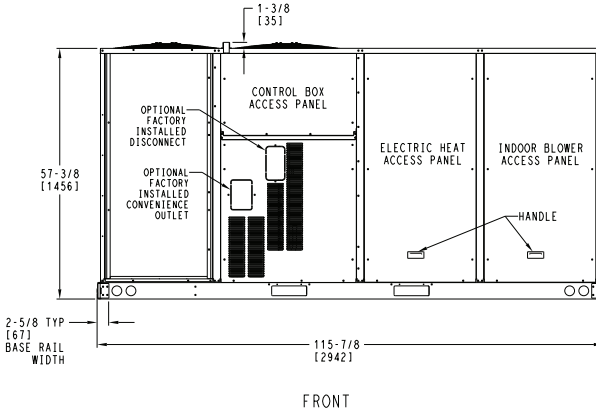
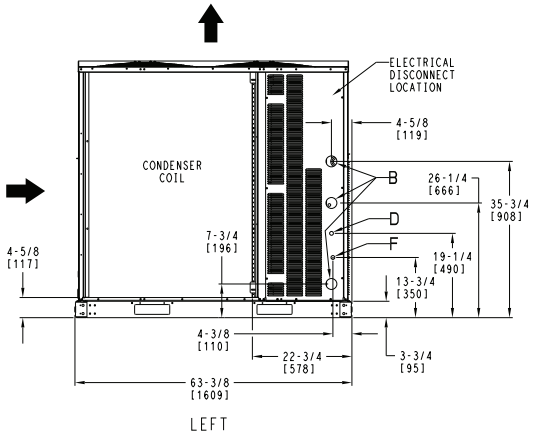
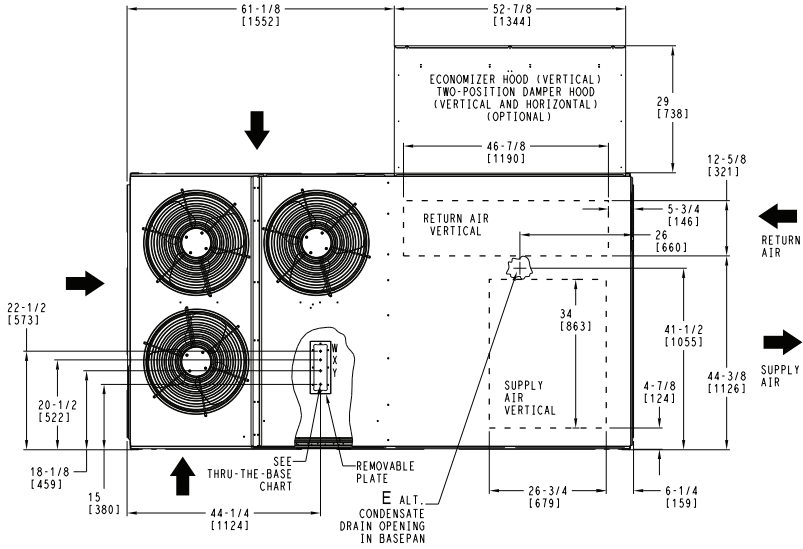
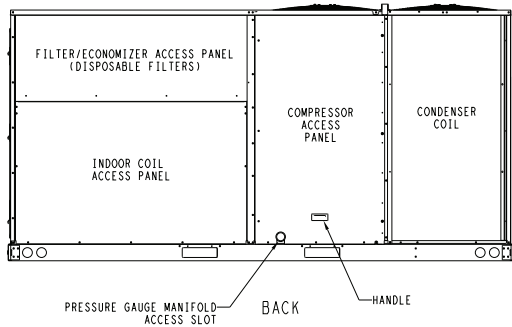

ITC CLASSIFICATION	SHEET	DATE	SUPERCEDES	RAF 180 SINGLE ZONE ELECTRICAL COOLING WITH ELECTRIC HEAT	50TM003167	REV
U.S. ECCN:NSR	1 OF 2	8/10/23	-			-

RAF180 Base Unit Dimensions (cont)

UNIT	STD UNIT WEIGHT		CORNER WEIGHT (A)		CORNER WEIGHT (B)		CORNER WEIGHT (C)		CORNER WEIGHT (D)		C.G.		
	LBS.	KG.	LBS.	KG.	LBS.	KG.	LBS.	KG.	LBS.	KG.	X	Y	Z
RAF-180	1325	601	370	168	312	142	294	133	349	158	53 [1345]	30 3/4 [781]	22 [559]

STANDARD UNIT WEIGHT IS WITHOUT ELECTRIC HEAT & WITHOUT PACKAGING.
FOR OPTIONS & ACCESSORIES, REFER TO THE PRODUCT DATA CATALOG.



THIS DOCUMENT IS THE PROPERTY OF CARRIER CORPORATION AND IS DELIVERED UPON THE EXPRESS CONDITION THAT THE CONTENTS WILL NOT BE DISCLOSED OR USED WITHOUT WRITTEN CONSENT.

SUBMISSION OF THESE DRAWINGS OR DOCUMENTS DOES NOT CONSTITUTE PAST PERFORMANCE OR ACCEPTANCE OF CONTRACT.

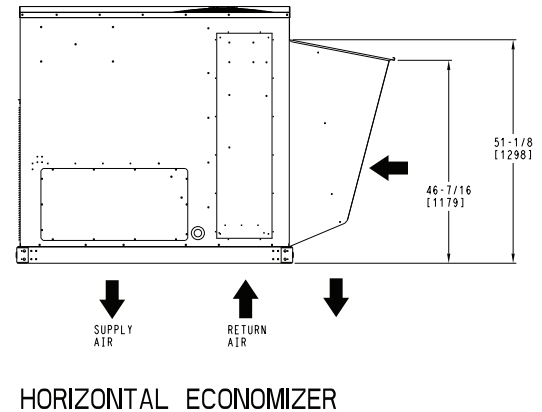
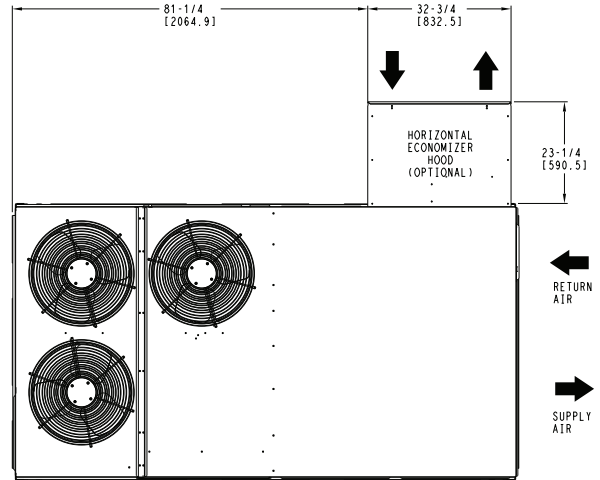
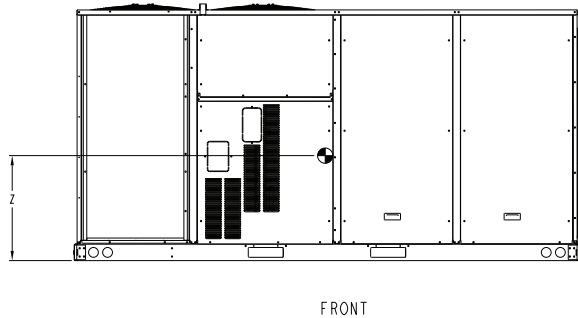
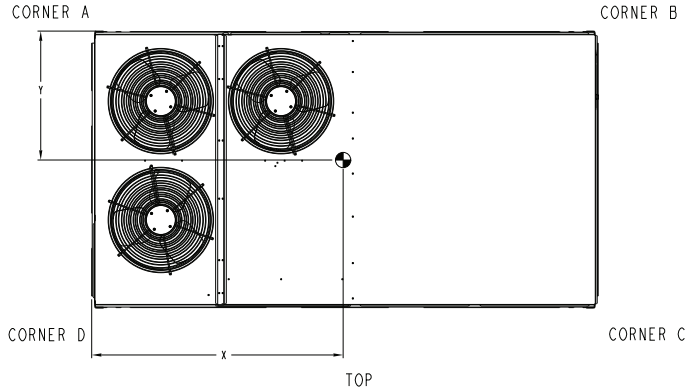

ITC CLASSIFICATION U.S. ECCN:NSR	SHEET 2 OF 2	DATE 8/10/23	SUPERCEDES -	RAF 180 SINGLE ZONE ELECTRICAL COOLING WITH ELECTRIC HEAT	50TM003167	REV -
-------------------------------------	-----------------	-----------------	-----------------	---	------------	----------

Base unit dimensions (cont)

RAF180 Base Unit Dimensions — Clearance

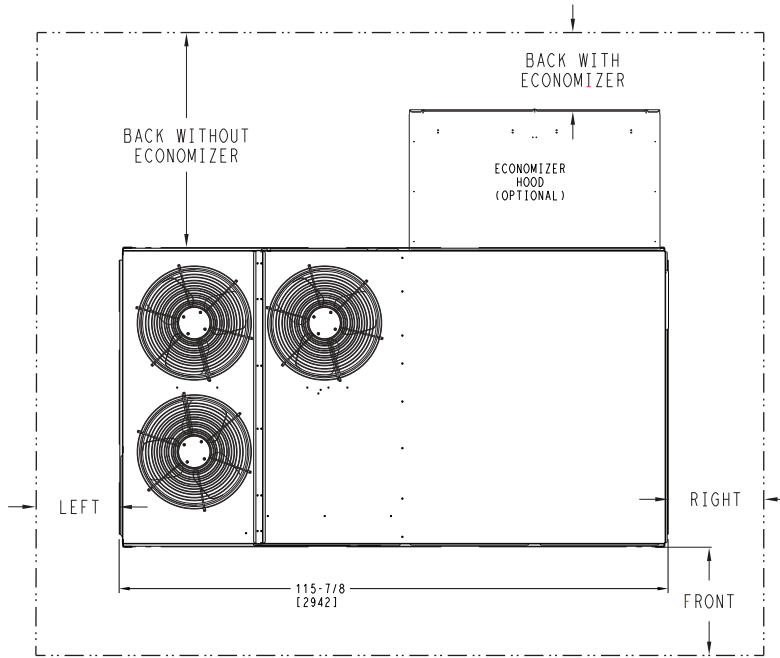

CLEARANCE^{a,b}

SURFACE	Service with Conductive Barrier	Service with Non-conductive Barrier	Operating Clearance
FRONT	48 in. (1219 mm)	36 in. (914 mm)	18 in. (457 mm)
LEFT	48 in. (1219 mm)	42 in. (1067 mm)	18 in. (457 mm)
BACK WITHOUT ECONOMIZER	48 in. (1219 mm)	42 in. (1067 mm)	18 in. (457 mm)
BACK WITH ECONOMIZER	36 in. (914 mm)	36 in. (914 mm)	18 in. (457 mm)
RIGHT	36 in. (914 mm)	36 in. (914 mm)	18 in. (457 mm)
TOP	72 in. (1829 mm)	72 in. (1829 mm)	72 in. (1829 mm)

NOTE(S):

- a. For all minimum clearances local codes or jurisdictions may prevail.
- b. See page 28 for RAF090-120 clearances. See page 31 for RAF150 clearances.

Roof Curb Dimensions — RGF/RAF090-150

ROOF CURB ACCESSORY #	A
CRRFCURB003A01	14" [356]
CRRFCURB004A01	24" [610]

- NOTES:
 1. ROOFCURB ACCESSORY IS SHIPPED DISASSEMBLED.
 2. INSULATED PANELS: 25.4 [1"] THK. POLYURETHANE FOAM, 44.5 [1-3/4] # DENSITY.
 3. DIMENSIONS IN [] ARE IN MILLIMETERS.
 4. ROOFCURB: 18 GAGE STEEL.
 5. ATTACH DUCTWORK TO CURB: FLANGES OF DUCT REST ON CURB).
 6. SERVICE CLEARANCE 4 FEET ON EACH SIDE.
 7. DIRECTION OF AIR FLOW.
 8. CONNECTOR PACKAGE CRBTMPWR002A01 IS FOR THRU-THE-CURB GAS TYPE PACKAGE CRBTMPWR004A01 IS FOR THRU-THE-BOTTOM TYPE GAS CONNECTIONS.

CONNECTOR PKG. ACC.	GAS CONNECTION TYPE	GAS FITTING	POWER WIRING FITTING	CONTROL WIRING FITTING	ACCESSORY CONVENIENCE OUTLET WIRING CONNECTOR
CRBTMPWR002A01	THRU THE CURB	3/4" [19] NPT	1 1/4" [31.7] NPT	1/2" [12.7] NPT	1/2" [12.7] NPT
CRBTMPWR004A01	THRU THE BOTTOM				

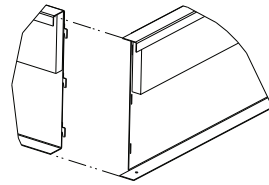
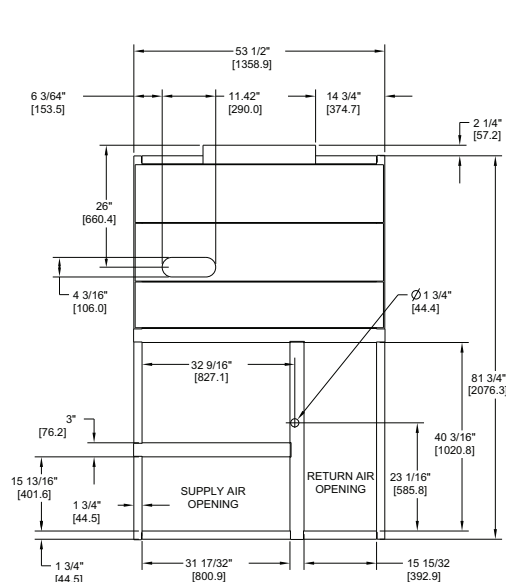

VIEW "B"
CORNER DETAIL

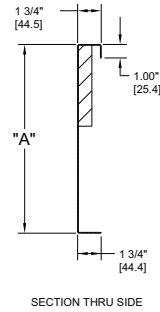

SECTION THRU SIDE

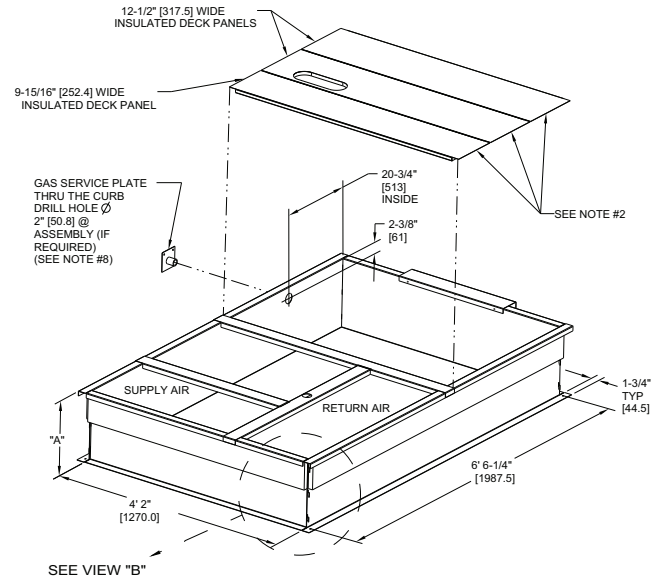
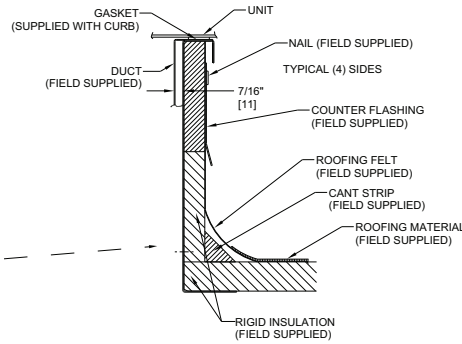

SEE VIEW "B"

CERTIFIED DRAWING

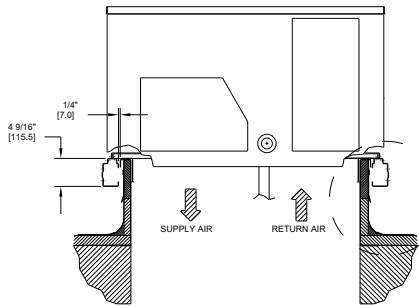

C	6' 6 1/4" WAS 6' 7 1/8", 4'2" WAS 4' 2 1/32", 18 GA WAS 16 GA.; 15 13/16" WAS 15 15/16"; NAIL FIELD SUPPLIED WAS WITH CURB	4/22/13	MMC	-	-	1067898
REV	REVISION RECORD	DATE	BY	CHKD	APPD	ECN NO.

DRAWING RELEASE LEVEL:		PRODUCTION				TITLE	
THIRD ANGLE PROJECTION		UNLESS OTHERWISE SPECIFIED DIMENSIONS ARE IN INCHES TOLERANCES ON:				THIS DOCUMENT AND THE INFORMATION CONTAINED THEREIN IS PROPRIETARY TO CARRIER CORPORATION AND SHALL NOT BE USED OR DISCLOSED TO OTHERS, IN WHOLE OR IN PART WITHOUT THE WRITTEN AUTHORIZATION OF CARRIER CORPORATION.	
MATERIAL	-	1 DEC	2 DEC	3 DEC	ANG	CURB ASY, ROOF	
ENGINEERING REQUIREMENTS	T-005, Y-002	AUTHORIZATION NUMBER				SIZE	DRAWING NUMBER
WEIGHT	-	1029120				D	50HJ405012
SURFACE FINISH	-	ENGINEERING	MANUFACTURING	DRAFTER		CHECKER	REV
MFG/PURCH	PURCH	MMC	12/16/09	MMC		12/16/09	C
MODEL (INTERNAL USE ONLY)		NEXT DRAWING		SCALE		DISTRIBUTION	
-		-		N/A		-	

Roof Curb Dimensions — RGF/RAF180

- NOTES:
 1. ROOFCURB ACCESSORY IS SHIPPED DISASSEMBLED.
 2. INSULATED PANELS: 1/2" THK. NEOPRENE FOAM, 1.0# DENSITY.
 3. DIMENSIONS IN () ARE IN MILLIMETERS.
 4. ROOFCURB SIDEWALLS: 16 GAGE STEEL.
 5. ATTACH DUCTWORK TO CURB. (FLANGES OF DUCT REST ON CURB).
 6. SERVICE CLEARANCE 4 FT ON EACH SIDE.
 7. DIRECTION OF AIR FLOW.
 8. "L" & "S" DESIGNATIONS DENOTE LOCATION OF COMMON CROSS RAIL. (POSITION "L" FOR LARGE DUCT OPENING CURB).

ROOF CURB ACCESSORY #	A
CRFRCURB074A00	14" [356]
CRFRCURB075A00	24" [610]

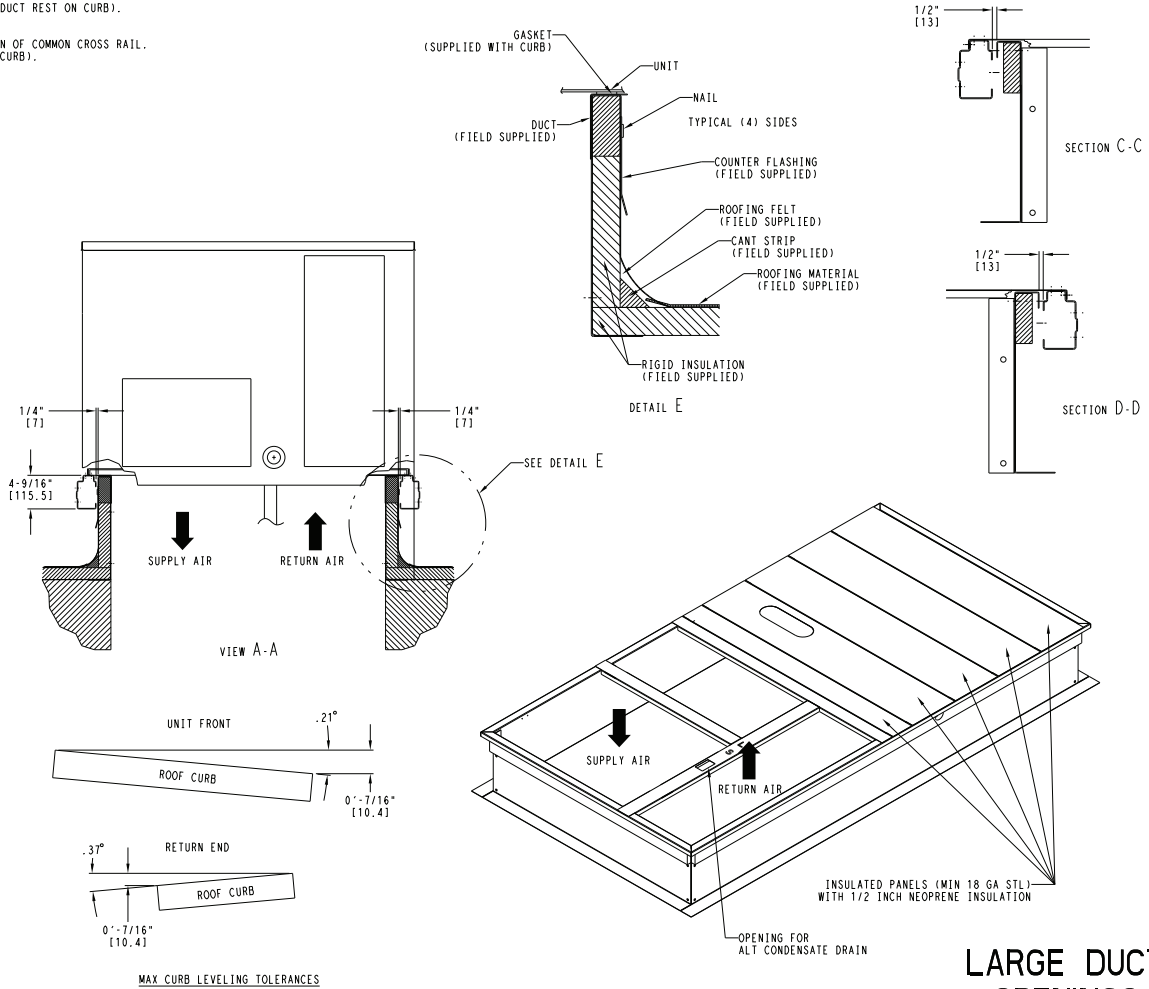
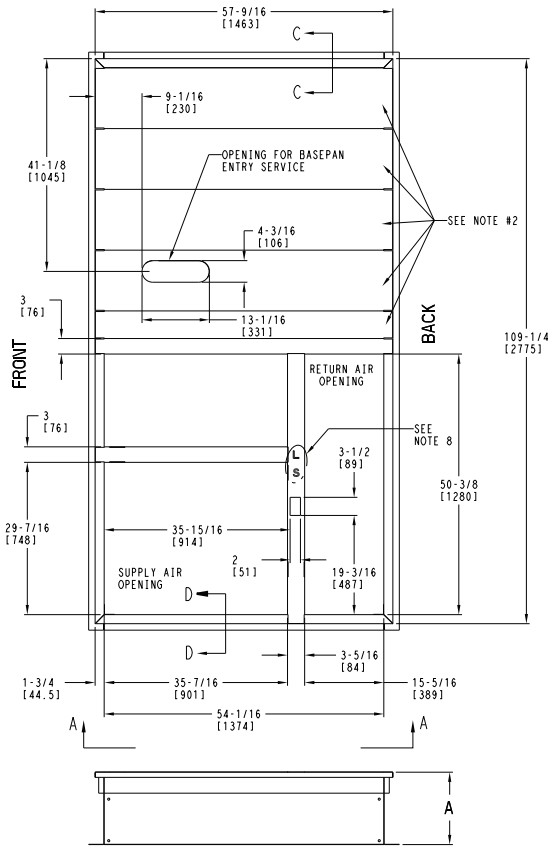

LARGE DUCT OPENINGS

50TM500780	REV B
------------	-------

Performance data

RGF/RAF090 Two-Stage Cooling Capacities

RGF/RAF090		AMBIENT TEMPERATURE (°F)																		
		85			95			105			115			125						
		EA (db)			EA (db)			EA (db)			EA (db)			EA (db)						
		75	80	85	75	80	85	75	80	85	75	80	85	75	80	85				
2250 cfm	EA (wb)	58	TC	80.7	80.7	91.2	77.4	77.4	87.5	73.8	73.8	83.6	70.0	70.0	79.3	65.9	65.9	74.7		
			SHC	70.2	80.7	91.2	67.3	77.4	87.5	64.1	73.8	83.6	60.7	70.0	79.3	57.1	65.9	74.7		
		62	TC	85.2	85.2	85.2	80.7	80.7	84.3	76.3	76.3	81.9	71.5	71.5	79.3	66.5	66.5	76.2		
			SHC	56.5	67.6	78.7	61.1	72.7	84.3	58.7	70.3	81.9	56.2	67.7	79.3	53.4	64.8	76.2		
		67	TC	93.4	93.4	93.4	88.9	88.9	88.9	84.0	84.0	84.0	78.8	78.8	78.8	73.3	73.3	73.3		
			SHC	51.8	63.4	75.0	49.7	61.3	72.9	47.4	59.0	70.7	45.0	56.7	68.3	42.5	54.2	65.9		
		72	TC	102.8	102.8	102.8	97.9	97.9	97.9	92.6	92.6	92.6	87.0	87.0	87.0	80.9	80.9	80.9		
			SHC	40.1	51.5	62.9	37.9	49.4	60.8	35.6	47.1	58.6	33.2	44.8	56.3	30.7	42.3	53.9		
		76	TC	—	111.1	111.1	—	105.8	105.8	—	100.1	100.1	—	94.0	94.0	—	87.6	87.6		
			SHC	—	41.5	53.8	—	39.5	51.9	—	37.3	47.3	—	35.0	45.7	—	32.6	43.6		
		2650 cfm	EA (wb)	58	TC	85.5	85.5	96.6	81.9	81.9	92.6	78.1	78.1	88.3	74.0	74.0	83.7	69.5	69.5	78.7
					SHC	74.4	85.5	96.6	71.3	81.9	92.6	67.9	78.1	88.3	64.2	74.0	83.7	60.2	69.5	78.7
62	TC			87.8	87.8	95.4	83.4	83.4	92.8	78.9	78.9	89.9	75.3	75.3	83.2	70.6	70.6	78.6		
	SHC			68.6	82.0	95.4	66.2	79.5	92.8	63.6	76.7	89.9	59.1	71.1	83.2	55.6	67.1	78.6		
67	TC			96.4	96.4	96.4	91.6	91.6	91.6	86.5	86.5	86.5	81.0	81.0	81.0	75.2	75.2	75.2		
	SHC			55.3	68.8	82.4	53.1	66.6	80.2	50.8	64.4	77.9	48.3	61.9	75.5	45.8	59.4	73.0		
72	TC			105.8	105.8	105.8	100.6	100.6	100.6	95.1	95.1	95.1	89.1	89.1	89.1	82.9	82.9	82.9		
	SHC			41.4	54.8	68.1	39.2	52.6	66.0	36.8	50.3	63.8	34.4	47.9	61.5	31.9	45.4	59.0		
76	TC			—	114.1	114.1	—	108.5	108.5	—	102.6	102.6	—	96.2	96.2	—	89.6	89.6		
	SHC			—	43.2	55.1	—	41.1	53.5	—	38.9	51.6	—	36.5	49.5	—	34.1	47.2		
3000 cfm	EA (wb)			58	TC	89.0	89.0	100.5	85.3	85.3	96.4	81.2	81.2	91.8	76.9	76.9	87.0	72.2	72.2	81.7
					SHC	77.5	89.0	100.5	74.2	85.3	96.4	70.6	81.2	91.8	66.7	76.9	87.0	62.6	72.2	81.7
		62	TC	90.0	90.0	102.0	85.7	85.7	98.7	82.0	82.0	93.2	77.4	77.4	88.9	72.3	72.3	85.1		
			SHC	72.6	87.3	102.0	69.8	84.2	98.7	66.0	79.6	93.2	62.7	75.8	88.9	59.4	72.3	85.1		
		67	TC	98.3	98.3	98.3	93.4	93.4	93.4	88.1	88.1	88.1	82.5	82.5	82.5	76.5	76.5	79.0		
			SHC	58.1	73.3	88.5	55.9	71.1	86.4	53.5	68.8	84.0	51.1	66.3	81.6	48.5	63.7	79.0		
		72	TC	107.8	107.8	107.8	102.5	102.5	102.5	96.7	96.7	96.7	90.6	90.6	90.6	84.2	84.2	84.2		
			SHC	42.3	57.4	72.5	40.1	55.2	70.3	37.7	52.9	68.1	35.3	50.5	65.7	32.8	48.0	63.2		
		76	TC	—	116.2	116.2	—	110.4	110.4	—	104.3	104.3	—	97.7	97.7	—	90.9	90.9		
			SHC	—	44.4	58.5	—	42.2	56.6	—	40.0	54.6	—	37.6	52.3	—	35.1	50.0		
		3400 cfm	EA (wb)	58	TC	92.5	92.5	104.4	88.5	88.5	100.0	84.2	84.2	95.2	79.6	79.6	90.1	74.8	74.8	84.7
					SHC	80.6	92.5	104.4	77.0	88.5	100.0	73.2	84.2	95.2	69.2	79.6	90.1	64.9	74.8	84.7
62	TC			94.5	94.5	101.5	90.3	90.3	97.8	84.3	84.3	99.0	79.7	79.7	93.7	74.8	74.8	88.1		
	SHC			73.3	87.4	101.5	70.3	84.1	97.8	69.6	84.3	99.0	65.7	79.7	93.7	61.6	74.8	88.1		
67	TC			100.1	100.1	100.1	95.0	95.0	95.0	89.5	89.5	90.7	83.8	83.8	88.2	77.6	77.6	85.4		
	SHC			61.2	78.3	95.3	58.9	76.0	93.1	56.6	73.6	90.7	54.1	71.1	88.2	51.5	68.4	85.4		
72	TC			109.7	109.7	109.7	104.1	104.1	104.1	98.2	98.2	98.2	91.9	91.9	91.9	85.4	85.4	85.4		
	SHC			43.2	60.2	77.2	41.0	58.0	75.0	38.6	55.7	72.7	36.2	53.3	70.3	33.7	50.8	67.9		
76	TC			—	118.0	118.0	—	112.1	112.1	—	105.8	105.8	—	99.0	99.0	—	84.7	84.7		
	SHC			—	45.5	61.7	—	43.3	59.7	—	41.0	57.6	—	38.5	55.3	—	52.2	73.0		
3750 cfm	EA (wb)			58	TC	95.0	95.0	107.3	90.9	90.9	102.7	86.5	86.5	97.8	81.7	81.7	92.4	76.6	76.6	86.7
					SHC	82.8	95.0	107.3	79.1	90.9	102.7	75.2	86.5	97.8	71.0	81.7	92.4	66.5	76.6	86.7
		62	TC	97.2	97.2	103.5	91.0	91.0	106.8	86.6	86.6	101.6	81.8	81.8	96.1	76.7	76.7	90.2		
			SHC	74.9	89.2	103.5	75.3	91.0	106.8	71.5	86.6	101.6	67.5	81.8	96.1	63.2	76.7	90.2		
		67	TC	101.4	101.4	101.4	96.2	96.2	98.8	90.6	90.6	96.3	84.7	84.7	93.6	78.5	78.5	90.8		
			SHC	63.8	82.4	101.1	61.5	80.2	98.8	59.1	77.7	96.3	56.6	75.1	93.6	54.0	72.4	90.8		
		72	TC	111.0	111.0	111.0	105.3	105.3	105.3	99.3	99.3	99.3	92.9	92.9	92.9	86.2	86.2	86.2		
			SHC	43.9	62.5	81.1	41.6	60.3	78.9	39.3	58.0	76.6	36.8	55.5	74.2	34.3	53.0	71.8		
		76	TC	—	119.3	119.3	—	113.3	113.3	—	106.8	106.8	—	99.9	99.9	—	92.9	92.9		
			SHC	—	46.2	64.2	—	44.0	62.1	—	41.6	59.9	—	39.2	57.6	—	36.7	55.2		

LEGEND

- Do Not Operate
- cfm Cubic Feet Per Minute (Supply Air)
- EA (db) Entering Air Temperature (dry bulb)
- EA (wb) Entering Air Temperature (wet bulb)
- SHC Sensible Heat Capacity (1000 Btuh) Gross
- TC Total Capacity (1000 Btuh) Gross

NOTE: See minimum-maximum airflow ratings on page 8.

Performance data (cont)

RGF/RAF090 Single-Stage Cooling Capacities

RGF/RAF090			AMBIENT TEMPERATURE (°F)																
			85			95			105			115			125				
			EA (db)			EA (db)			EA (db)			EA (db)			EA (db)				
			75	80	85	75	80	85	75	80	85	75	80	85	75	80	85		
1150 cfm	EA (wb)	58	TC	41.5	41.5	47.1	40.2	40.2	45.6	38.7	38.7	43.9	37.0	37.0	42.0	35.1	35.1	39.9	
			SHC	35.9	41.5	47.1	34.8	40.2	45.6	33.5	38.7	43.9	32.0	37.0	42.0	30.4	35.1	39.9	
		62	TC	44.1	44.1	44.6	42.3	42.3	43.7	40.2	40.2	42.8	38.0	38.0	41.8	35.6	35.6	40.6	
			SHC	32.4	38.5	44.6	31.5	37.6	43.7	30.6	36.7	42.8	29.6	35.7	41.8	28.5	34.5	40.6	
		67	TC	49.0	49.0	49.0	47.0	47.0	47.0	44.8	44.8	44.8	42.3	42.3	42.3	39.7	39.7	39.7	
			SHC	26.6	32.7	38.8	25.8	31.9	38.0	24.9	31.0	37.1	23.9	30.0	36.1	22.8	29.0	35.1	
	72	TC	54.3	54.3	54.3	52.1	52.1	52.1	49.7	49.7	49.7	47.1	47.1	47.1	44.2	44.2	44.2		
		SHC	20.8	26.8	32.7	20.0	26.0	32.0	19.0	25.1	31.1	18.1	24.1	30.2	17.0	23.1	29.1		
	76	TC	—	59.0	59.0	—	56.6	56.6	—	54.0	54.0	—	51.1	51.1	—	44.8	44.8		
		SHC	—	21.8	28.1	—	21.0	27.4	—	20.2	25.4	—	19.3	24.8	—	21.3	27.5		
	1350 cfm	EA (wb)	58	TC	44.3	44.3	50.2	42.8	42.8	48.5	41.2	41.2	46.7	39.3	39.3	44.6	37.3	37.3	42.3
				SHC	38.4	44.3	50.2	37.1	42.8	48.5	35.7	41.2	46.7	34.1	39.3	44.6	32.3	37.3	42.3
62			TC	45.8	45.8	49.5	43.8	43.8	48.6	41.7	41.7	47.5	40.0	40.0	44.6	37.4	37.4	44.0	
			SHC	35.3	42.4	49.5	34.4	41.5	48.6	33.4	40.5	47.5	31.5	38.0	44.6	30.7	37.4	44.0	
67			TC	50.7	50.7	50.7	48.6	48.6	48.6	46.2	46.2	46.2	43.7	43.7	43.7	40.9	40.9	40.9	
			SHC	28.6	35.7	42.8	27.7	34.9	42.0	26.8	33.9	41.1	25.8	32.9	40.1	24.7	31.9	39.0	
72		TC	56.2	56.2	56.2	53.8	53.8	53.8	51.2	51.2	51.2	48.4	48.4	48.4	45.4	45.4	45.4		
		SHC	21.7	28.7	35.7	20.8	27.9	34.9	19.9	27.0	34.0	18.9	26.0	33.1	17.8	24.9	32.0		
76		TC	—	60.8	60.8	—	58.3	58.3	—	55.6	55.6	—	52.6	52.6	—	49.3	49.3		
		SHC	—	22.9	29.2	—	22.1	28.6	—	21.3	27.9	—	20.3	27.1	—	19.3	26.1		
1600 cfm		EA (wb)	58	TC	47.2	47.2	53.4	45.5	45.5	51.6	43.7	43.7	49.5	41.7	41.7	47.3	39.5	39.5	44.8
				SHC	40.9	47.2	53.4	39.5	45.5	51.6	37.9	43.7	49.5	36.2	41.7	47.3	34.2	39.5	44.8
	62		TC	47.5	47.5	54.8	46.0	46.0	52.7	43.8	43.8	51.5	41.8	41.8	49.2	39.5	39.5	46.6	
			SHC	38.5	46.6	54.8	37.1	44.9	52.7	36.0	43.8	51.5	34.4	41.8	49.2	32.5	39.5	46.6	
	67		TC	52.4	52.4	52.4	50.1	50.1	50.1	47.6	47.6	47.6	44.9	44.9	44.9	41.9	41.9	43.7	
			SHC	30.9	39.3	47.7	30.0	38.4	46.8	29.0	37.5	45.9	28.0	36.4	44.8	26.9	35.3	43.7	
	72	TC	57.9	57.9	57.9	55.4	55.4	55.4	52.7	52.7	52.7	49.7	49.7	49.7	48.2	48.2	48.2		
		SHC	22.7	31.0	39.3	21.8	30.1	38.5	20.8	29.2	37.5	19.8	28.2	36.5	17.8	26.4	35.0		
	76	TC	—	62.6	62.6	—	60.0	60.0	—	57.1	57.1	—	53.9	53.9	—	50.5	50.5		
		SHC	—	24.2	32.1	—	23.4	31.3	—	22.4	30.5	—	21.4	29.6	—	20.4	28.6		
	1800 cfm	EA (wb)	58	TC	49.1	49.1	55.6	47.4	47.4	53.6	45.4	45.4	51.4	43.3	43.3	49.0	41.0	41.0	46.4
				SHC	42.6	49.1	55.6	41.1	47.4	53.6	39.4	45.4	51.4	37.6	43.3	49.0	35.5	41.0	46.4
62			TC	48.8	48.8	57.8	47.4	47.4	55.8	45.5	45.5	53.5	43.3	43.3	51.0	41.0	41.0	48.3	
			SHC	39.8	48.8	57.8	39.0	47.4	55.8	37.4	45.5	53.5	35.7	43.3	51.0	33.7	41.0	48.3	
67			TC	53.4	53.4	53.4	51.0	51.0	51.0	48.4	48.4	49.6	45.6	45.6	48.5	42.6	42.6	47.2	
			SHC	32.6	42.0	51.4	31.7	41.1	50.6	30.8	40.2	49.6	29.7	39.1	48.5	28.5	37.9	47.2	
72		TC	59.0	59.0	59.0	56.4	56.4	56.4	53.5	53.5	53.5	50.5	50.5	50.5	47.2	47.2	47.2		
		SHC	23.4	32.7	42.0	22.5	31.8	41.2	21.5	30.9	40.2	20.5	29.9	39.2	19.3	28.7	38.1		
76		TC	—	63.7	63.7	—	61.0	61.0	—	58.0	58.0	—	54.7	54.7	—	51.2	51.2		
		SHC	—	25.1	34.1	—	24.2	33.3	—	23.3	32.4	—	22.3	31.5	—	21.2	30.4		
2050 cfm		EA (wb)	58	TC	51.2	51.2	57.9	49.3	49.3	55.8	47.2	47.2	53.4	45.0	45.0	50.9	42.5	42.5	48.1
				SHC	44.4	51.2	57.9	42.8	49.3	55.8	41.0	47.2	53.4	39.0	45.0	50.9	36.9	42.5	48.1
	62		TC	51.2	51.2	60.2	49.3	49.3	58.0	47.3	47.3	55.6	45.0	45.0	52.9	42.5	42.5	50.0	
			SHC	42.2	51.2	60.2	40.7	49.3	58.0	39.0	47.3	55.6	37.1	45.0	52.9	35.0	42.5	50.0	
	67		TC	54.4	54.4	56.0	51.9	51.9	55.0	49.2	49.2	53.9	46.4	46.4	52.8	43.3	43.3	51.5	
			SHC	34.7	45.4	56.0	33.8	44.4	55.0	32.8	43.4	53.9	31.7	42.2	52.8	30.5	41.0	51.5	
	72	TC	60.0	60.0	60.0	57.3	57.3	57.3	54.4	54.4	54.4	51.2	51.2	51.2	47.8	47.8	47.8		
		SHC	24.2	34.8	45.3	23.3	33.9	44.5	22.3	32.9	43.5	21.2	31.9	42.5	20.1	30.8	41.4		
	76	TC	—	64.8	64.8	—	62.0	62.0	—	58.8	58.8	—	55.4	55.4	—	51.8	51.8		
		SHC	—	26.1	36.4	—	25.2	35.6	—	24.3	34.7	—	23.3	33.7	—	22.1	32.6		

LEGEND

—	— Do Not Operate
cfm	— Cubic Feet Per Minute (Supply Air)
EA (db)	— Entering Air Temperature (dry bulb)
EA (wb)	— Entering Air Temperature (wet bulb)
SHC	— Sensible Heat Capacity (1000 Btuh) Gross
TC	— Total Capacity (1000 Btuh) Gross

NOTE: See minimum-maximum airflow ratings on page 8.

Performance data (cont)

RGF/RAF090 — Unit with Hot Gas Re-Heat System in Subcooling Mode — Cooling Capacities

TEMP (°F) AIR ENTERING CONDENSER (Edb)		AIR ENTERING EVAPORATOR — SCFM/BF (80°F db)								
		2250/0.14			3000/0.15			3750/0.17		
		Air Entering Evaporator — Ewb (°F)								
		72	67	62	72	67	62	72	67	62
75	TC	95.0	86.0	77.0	104.0	93.0	83.0	108.0	97.0	87.0
	SHC	38.0	49.0	60.0	47.0	60.0	72.0	53.0	69.0	83.0
	kW	6.4	6.4	6.3	6.6	6.5	6.4	6.6	6.5	6.4
85	TC	86.0	81.0	71.0	97.0	86.0	77.0	101.0	91.0	81.0
	SHC	29.0	44.0	54.0	40.0	53.0	67.0	46.0	63.0	76.0
	kW	6.9	7.0	7.0	7.2	7.1	7.0	7.2	7.2	7.1
95	TC	84.0	74.0	65.0	90.0	80.0	71.0	94.0	83.0	74.0
	SHC	28.0	38.0	49.0	34.0	47.0	61.0	40.0	56.0	70.0
	kW	7.8	7.7	7.7	7.9	7.8	7.7	8.0	7.9	7.8
105	TC	77.0	68.0	59.0	82.0	73.0	64.0	86.0	76.0	68.0
	SHC	22.0	32.0	43.0	27.0	41.0	55.0	33.0	49.0	64.0
	kW	8.7	8.5	8.4	8.8	8.6	8.5	8.8	8.7	8.6
115	TC	70.0	61.0	53.0	74.0	65.0	57.0	78.0	68.0	60.0
	SHC	15.0	26.0	37.0	20.0	35.0	49.0	25.0	42.0	57.0
	kW	9.5	9.4	9.3	9.6	9.5	9.4	9.7	9.5	9.4
125	TC	62.0	54.0	46.0	66.0	58.0	50.0	69.0	60.0	53.0
	SHC	8.0	20.0	31.0	13.0	28.0	42.0	18.0	35.0	50.0
	kW	10.5	10.4	10.3	10.6	10.5	10.3	10.7	10.5	10.4

RGF/RAF090 — Unit with Hot Gas Re-Heat System in Hot Gas Reheat Mode — Cooling Capacities

TEMP (°F) AIR ENTERING CONDENSER (Edb)		AIR ENTERING EVAPORATOR — Ewb (°F)								
		75 Dry Bulb 62.5 Wet Bulb (50% Relative)			75 Dry Bulb 64 Wet Bulb (56% Relative)			75 Dry Bulb 65.3 Wet Bulb (60% Relative)		
		Air Entering Evaporator — cfm								
		2250	3000	3750	2250	3000	3750	2250	3000	3750
80	TC	35.0	39.0	41.0	37.0	40.0	42.0	38.0	41.0	43.0
	SHC	8.0	14.0	21.0	4.0	9.0	15.0	0.0	5.0	10.0
	kW	6.6	6.6	6.6	6.6	6.6	6.6	6.6	6.6	6.6
75	TC	37.0	41.0	43.0	39.0	42.0	44.0	40.0	43.0	46.0
	SHC	9.0	16.0	23.0	6.0	12.0	17.0	2.0	7.0	12.0
	kW	5.9	5.9	6.0	5.9	6.0	6.0	6.0	6.1	6.1
70	TC	40.0	43.0	45.0	41.0	44.0	47.0	42.0	46.0	48.0
	SHC	11.0	18.0	25.0	8.0	13.0	19.0	4.0	9.0	14.0
	kW	5.7	5.7	5.7	5.7	5.7	5.7	5.7	5.7	5.7
60	TC	44.0	47.0	50.0	45.0	49.0	51.0	47.0	50.0	53.0
	SHC	15.0	22.0	29.0	11.0	17.0	23.0	8.0	13.0	18.0
	kW	5.7	5.7	5.7	5.7	5.7	5.7	5.7	5.7	5.7
50	TC	47.0	51.0	54.0	49.0	53.0	55.0	51.0	54.0	57.0
	SHC	19.0	26.0	33.0	15.0	21.0	27.0	12.0	17.0	22.0
	kW	5.7	5.6	5.6	5.6	5.6	5.6	5.6	5.6	5.6
40	TC	51.0	55.0	58.0	53.0	57.0	60.0	54.0	59.0	61.0
	SHC	22.0	30.0	37.0	18.0	25.0	31.0	15.0	21.0	26.0
	kW	5.6	5.6	5.6	5.6	5.6	5.6	5.6	5.6	5.6

LEGEND

Edb	—	Entering Dry Bulb
Ewb	—	Entering Wet Bulb
kW	—	Compressor Power Input
SCFM/BF	—	Standard Cubic Feet per Minute/Bypass Factor
SHC	—	Sensible Heat Capacity (1000 Btuh) Gross
TC	—	Total Capacity (1000 Btuh) Gross

Performance data (cont)

RGF/RAF102 Two-Stage Cooling Capacities

RGF/RAF102			AMBIENT TEMPERATURE (°F)																
			85			95			105			115			125				
			EA (db)			EA (db)			EA (db)			EA (db)			EA (db)				
			75	80	85	75	80	85	75	80	85	75	80	85	75	80	85		
2550 cfm	EA (wb)	58	TC	88.4	88.4	99.8	84.9	84.9	95.9	81.0	81.0	91.6	76.5	76.5	86.6	71.4	71.4	80.9	
			SHC	76.9	88.4	99.8	73.9	84.9	95.9	70.4	81.0	91.6	66.4	76.5	86.6	62.0	71.4	80.9	
		62	TC	92.6	92.6	95.8	88.2	88.2	93.6	88.5	88.5	88.5	77.6	77.6	88.0	71.5	71.5	84.2	
			SHC	69.9	82.9	95.8	67.7	80.6	93.6	60.6	70.0	79.5	62.3	75.1	88.0	59.0	71.5	84.2	
		67	TC	102.2	102.2	102.2	97.3	97.3	97.3	91.8	91.8	91.8	85.7	85.7	85.7	78.9	78.9	78.9	
			SHC	57.2	70.0	83.0	54.9	67.8	80.6	52.4	65.4	78.3	49.8	62.7	75.7	46.8	59.8	72.8	
	72	TC	112.8	112.8	112.8	107.4	107.4	107.4	101.5	101.5	101.5	94.7	94.7	94.7	87.4	87.4	87.4		
		SHC	44.4	57.2	69.9	42.1	54.9	67.8	39.6	52.4	65.3	36.9	49.7	62.7	33.9	46.9	59.9		
	76	TC	—	122.2	122.2	—	116.4	116.4	—	109.9	109.9	—	102.8	102.8	—	94.9	94.9		
		SHC	—	46.6	59.8	—	44.3	55.9	—	41.9	54.0	—	39.2	51.6	—	36.4	49.0		
	3000 cfm	EA (wb)	58	TC	93.8	93.8	105.9	90.1	90.1	101.8	85.7	85.7	96.9	81.0	81.0	91.6	75.5	75.5	85.4
				SHC	81.7	93.8	105.9	78.4	90.1	101.8	74.6	85.7	96.9	70.3	81.0	91.6	65.5	75.5	85.4
62			TC	101.6	101.6	101.6	95.6	95.6	95.6	86.2	86.2	99.9	81.1	81.1	95.3	75.6	75.6	88.9	
			SHC	70.4	81.4	92.2	69.2	81.2	93.2	70.5	85.2	99.9	66.9	81.1	95.3	62.3	75.6	88.9	
67			TC	105.6	105.6	105.6	100.3	100.3	100.3	94.5	94.5	94.5	84.4	84.4	84.4	80.1	80.1	80.1	
			SHC	61.2	76.5	91.6	59.0	74.1	89.3	56.4	71.6	86.8	38.5	53.8	69.0	47.4	62.7	78.0	
72		TC	116.4	116.4	116.4	110.8	110.8	110.8	104.3	104.3	104.3	97.2	97.2	97.2	89.4	89.4	89.4		
		SHC	46.1	61.1	76.2	43.8	58.9	73.9	41.2	56.4	71.5	38.4	53.6	68.7	35.4	50.6	65.8		
76		TC	—	126.0	126.0	—	119.7	119.7	—	112.9	112.9	—	105.3	105.3	—	97.1	97.1		
		SHC	—	48.8	62.9	—	46.4	60.8	—	43.8	58.4	—	41.1	55.8	—	38.2	53.2		
3400 cfm		EA (wb)	58	TC	98.0	98.0	110.6	93.9	93.9	106.1	89.3	89.3	100.9	84.1	84.1	95.1	78.3	78.3	88.6
				SHC	85.3	98.0	110.6	81.8	93.9	106.1	77.7	89.3	100.9	73.1	84.1	95.1	68.0	78.3	88.6
	62		TC	101.1	101.1	108.4	94.8	94.8	108.8	89.5	89.5	105.0	84.4	84.4	99.1	78.6	78.6	92.4	
			SHC	78.4	93.4	108.4	77.1	93.0	108.8	73.9	89.5	105.0	69.6	84.4	99.1	64.8	78.6	92.4	
	67		TC	107.9	107.9	107.9	102.5	102.5	102.5	96.5	96.5	96.5	89.6	89.6	91.3	82.2	82.2	88.3	
			SHC	64.7	81.8	98.9	61.2	78.3	95.5	58.7	75.9	93.1	57.0	74.1	91.3	54.0	71.2	88.3	
	72	TC	118.9	118.9	118.9	112.9	112.9	112.9	106.2	106.2	106.2	99.2	99.2	99.2	90.8	90.8	90.8		
		SHC	47.5	64.5	81.6	45.1	62.1	79.2	42.4	59.5	76.6	39.8	56.9	74.0	36.7	53.8	71.0		
	76	TC	—	128.4	128.4	—	122.0	122.0	—	115.0	115.0	—	107.0	107.0	—	98.5	98.5		
		SHC	—	50.4	66.8	—	48.0	64.5	—	45.5	62.1	—	42.6	59.4	—	39.7	56.6		
	3850 cfm	EA (wb)	58	TC	101.7	101.7	114.8	97.4	97.4	110.0	92.7	92.7	104.7	87.1	87.1	98.5	81.4	81.4	92.0
				SHC	88.6	101.7	114.8	84.9	97.4	110.0	80.7	92.7	104.7	75.8	87.1	98.5	70.7	81.4	92.0
62			TC	102.1	102.1	119.5	97.8	97.8	114.6	92.8	92.8	108.9	87.4	87.4	102.6	81.5	81.5	95.7	
			SHC	84.6	102.1	119.5	80.9	97.8	114.6	76.7	92.8	108.9	72.2	87.4	102.6	67.2	81.5	95.7	
67			TC	110.4	110.4	110.4	104.3	104.3	104.9	98.1	98.1	102.1	91.1	91.1	99.1	83.5	83.5	95.8	
			SHC	67.7	87.0	106.3	66.2	85.5	104.9	63.5	82.8	102.1	60.6	79.9	99.1	57.5	76.6	95.8	
72		TC	121.1	121.1	121.1	114.8	114.8	114.8	108.0	108.0	108.0	100.5	100.5	100.5	92.3	92.3	92.3		
		SHC	48.9	68.1	87.3	46.5	65.8	85.1	43.8	63.1	82.4	41.0	60.4	79.7	38.0	57.4	76.7		
76		TC	—	130.7	130.7	—	124.0	124.0	—	116.7	116.7	—	108.6	108.6	—	99.6	99.6		
		SHC	—	52.1	70.8	—	49.7	68.5	—	47.1	66.0	—	44.3	63.3	—	41.2	60.3		
4250 cfm		EA (wb)	58	TC	104.9	104.9	118.3	100.3	100.3	113.1	95.3	95.3	107.6	89.7	89.7	101.3	83.3	83.3	94.1
				SHC	91.4	104.9	118.3	87.3	100.3	113.1	82.9	95.3	107.6	78.0	89.7	101.3	72.3	83.3	94.1
	62		TC	105.0	105.0	123.0	100.5	100.5	117.7	95.4	95.4	112.0	89.7	89.7	105.3	83.4	83.4	98.1	
			SHC	87.0	105.0	123.0	83.3	100.5	117.7	78.9	95.4	112.0	74.1	89.7	105.3	68.9	83.4	98.1	
	67		TC	111.3	111.3	114.1	105.7	105.7	111.8	99.2	99.2	108.9	92.1	92.1	105.7	84.6	84.6	102.2	
			SHC	71.7	92.9	114.1	69.4	90.5	111.8	66.6	87.7	108.9	63.7	84.7	105.7	60.5	81.4	102.2	
	72	TC	122.6	122.6	122.6	116.2	116.2	116.2	109.3	109.3	109.3	101.7	101.7	101.7	93.4	93.4	93.4		
		SHC	50.1	71.3	92.5	47.6	68.8	90.1	45.0	66.2	87.4	42.1	63.3	84.5	39.2	60.5	81.8		
	76	TC	—	132.4	132.4	—	125.5	125.5	—	117.9	117.9	—	109.6	109.6	—	—	—		
		SHC	—	53.5	74.2	—	51.0	71.8	—	48.4	69.3	—	45.5	66.5	—	—	—		

LEGEND

—	Do Not Operate
cfm	Cubic Feet Per Minute (Supply Air)
EA (db)	Entering Air Temperature (dry bulb)
EA (wb)	Entering Air Temperature (wet bulb)
SHC	Sensible Heat Capacity (1000 Btu/h) Gross
TC	Total Capacity (1000 Btu/h) Gross

NOTE: See minimum-maximum airflow ratings on page 8.

Performance data (cont)

RGF/RAF102 Single-Stage Cooling Capacities

RGF/RAF102		AMBIENT TEMPERATURE (°F)																
		85			95			105			115			125				
		EA (db)			EA (db)			EA (db)			EA (db)			EA (db)				
cfm	EA (wb)	58	TC	75	80	85	75	80	85	75	80	85	75	80	85	75	80	85
				1275	EA (wb)	58												
62	TC	45.7	45.7	46.8		42.2	42.2	44.5	38.5	38.5	42.1	38.8	38.8	44.9	31.1	31.1	35.3	
	SHC	33.0	39.9	46.8		30.7	37.6	44.5	28.2	35.1	42.1	32.7	38.8	44.9	22.4	28.9	35.3	
67	TC	51.7	51.7	51.7		48.1	48.1	48.1	44.1	44.1	44.1	39.9	39.9	39.9	35.2	35.2	35.2	
	SHC	27.1	34.0	40.9		24.7	31.6	38.5	22.3	29.2	36.1	19.7	26.6	33.5	17.0	23.9	30.9	
72	TC	58.3	58.3	58.3		54.4	54.4	54.4	50.2	50.2	50.2	45.7	45.7	45.7	40.8	40.8	40.8	
	SHC	21.1	27.9	34.7		18.7	25.5	32.4	16.2	23.1	29.9	13.7	20.5	27.4	11.0	17.8	24.7	
76	TC	—	—	—		—	—	—	—	—	—	—	—	—	—	—	—	
	SHC	—	—	—	—	—	—	—	—	—	—	—	—	—	—	—		
1500	EA (wb)	58	TC	46.3	46.3	52.9	43.2	43.2	49.6	40.0	40.0	46.1	36.4	36.4	42.3	32.6	32.6	38.1
			SHC	39.7	46.3	52.9	36.9	43.2	49.6	33.9	40.0	46.1	30.6	36.4	42.3	27.1	32.6	38.1
		62	TC	49.6	49.6	56.6	44.2	44.2	50.3	41.2	41.2	46.3	36.5	36.5	44.3	32.7	32.7	40.1
			SHC	40.8	48.7	56.6	34.2	42.3	50.3	31.1	38.7	46.3	28.7	36.5	44.3	25.3	32.7	40.1
		67	TC	53.9	53.9	53.9	50.1	50.1	50.1	47.2	47.2	47.2	41.5	41.5	41.5	37.6	37.6	38.6
			SHC	29.6	37.6	45.7	27.1	35.2	43.3	27.9	35.9	44.0	22.0	30.1	38.2	22.4	30.5	38.6
		72	TC	60.7	60.7	60.7	56.6	56.6	56.6	52.2	52.2	52.2	47.4	47.4	47.4	—	—	—
			SHC	22.3	30.4	38.4	19.9	27.9	36.0	17.4	25.4	33.5	14.8	22.8	30.9	—	—	—
76	TC	—	—	—	—	—	—	—	—	—	—	—	—	—	—	—		
	SHC	—	—	—	—	—	—	—	—	—	—	—	—	—	—	—		
1700	EA (wb)	58	TC	49.0	49.0	55.8	45.7	45.7	52.4	42.3	42.3	48.7	38.6	38.6	44.7	34.6	34.6	40.3
			SHC	42.1	49.0	55.8	39.1	45.7	52.4	35.9	42.3	48.7	32.5	38.6	44.7	28.9	34.6	40.3
		62	TC	50.2	50.2	56.0	45.8	45.8	54.7	42.4	42.4	50.9	38.7	38.7	46.8	34.7	34.7	42.3
			SHC	39.0	47.5	56.0	37.0	45.8	54.7	33.9	42.4	50.9	30.6	38.7	46.8	27.0	34.7	42.3
		67	TC	55.5	55.5	55.5	51.4	51.4	51.4	47.2	47.2	47.2	42.6	42.6	42.6	37.6	37.6	39.5
			SHC	31.6	40.8	49.9	29.2	38.3	47.5	26.6	35.8	44.9	24.0	33.1	42.3	21.2	30.3	39.5
		72	TC	62.3	62.3	62.3	58.1	58.1	58.1	53.5	53.5	53.5	—	—	—	—	—	—
			SHC	23.3	32.4	41.5	20.9	29.9	39.0	18.3	27.4	36.5	—	—	—	—	—	—
76	TC	—	—	—	—	—	—	—	—	—	—	—	—	—	—	—		
	SHC	—	—	—	—	—	—	—	—	—	—	—	—	—	—	—		
1925	EA (wb)	58	TC	51.5	51.5	58.7	48.1	48.1	55.0	44.6	44.6	51.2	40.7	40.7	47.0	36.5	36.5	42.4
			SHC	44.4	51.5	58.7	41.2	48.1	55.0	38.0	44.6	51.2	34.4	40.7	47.0	30.6	36.5	42.4
		62	TC	51.6	51.6	61.2	48.2	48.2	57.4	44.6	44.6	53.5	40.8	40.8	49.2	36.6	36.6	44.5
			SHC	42.0	51.6	61.2	39.0	48.2	57.4	35.8	44.6	53.5	32.4	40.8	49.2	28.6	36.6	44.5
		67	TC	56.8	56.8	56.8	52.7	52.7	52.7	48.3	48.3	49.4	43.5	43.5	46.7	38.4	38.4	43.8
			SHC	33.8	44.1	54.5	31.4	41.7	52.0	28.8	39.1	49.4	26.1	36.4	46.7	23.2	33.5	43.8
		72	TC	63.8	63.8	63.8	—	—	—	—	—	—	—	—	—	—	—	—
			SHC	24.3	34.6	44.8	—	—	—	—	—	—	—	—	—	—	—	—
76	TC	—	—	—	—	—	—	—	—	—	—	—	—	—	—	—		
	SHC	—	—	—	—	—	—	—	—	—	—	—	—	—	—	—		
2125	EA (wb)	58	TC	53.5	53.5	60.9	50.0	50.0	57.1	46.3	46.3	53.1	42.3	42.3	48.8	38.0	38.0	44.1
			SHC	46.1	53.5	60.9	42.9	50.0	57.1	39.5	46.3	53.1	35.8	42.3	48.8	31.9	38.0	44.1
		62	TC	53.6	53.6	63.4	50.1	50.1	59.6	46.4	46.4	55.5	42.4	42.4	51.0	38.0	38.0	46.2
			SHC	43.7	53.6	63.4	40.6	50.1	59.6	37.3	46.4	55.5	33.7	42.4	51.0	29.9	38.0	46.2
		67	TC	57.8	57.8	58.4	53.6	53.6	55.9	49.1	49.1	53.3	44.3	44.3	50.5	39.1	39.1	47.5
			SHC	35.7	47.1	58.4	33.2	44.5	55.9	30.6	41.9	53.3	27.8	39.2	50.5	25.0	36.2	47.5
		72	TC	—	—	—	—	—	—	—	—	—	—	—	—	—	—	—
			SHC	—	—	—	—	—	—	—	—	—	—	—	—	—	—	—
76	TC	—	—	—	—	—	—	—	—	—	—	—	—	—	—	—		
	SHC	—	—	—	—	—	—	—	—	—	—	—	—	—	—	—		

LEGEND

- Do Not Operate
- cfm Cubic Feet Per Minute (Supply Air)
- EA (db) Entering Air Temperature (dry bulb)
- EA (wb) Entering Air Temperature (wet bulb)
- SHC Sensible Heat Capacity (1000 Btuh) Gross
- TC Total Capacity (1000 Btuh) Gross

NOTE: See minimum-maximum airflow ratings on page 8.

Performance data (cont)

RGF/RAF102 — Unit with Hot Gas Re-Heat System in Subcooling Mode — Cooling Capacities

TEMP (°F) AIR ENTERING CONDENSER (Edb)		AIR ENTERING EVAPORATOR — SCFM/BF (80°F db)								
		2550/0.11			3400/0.14			4250/0.15		
		Air Entering Evaporator — Ewb (°F)								
		72	67	62	72	67	62	72	67	62
75	TC	108.0	96.0	86.0	108.0	97.0	90.0	119.0	107.0	97.0
	SHC	46.0	57.0	69.0	48.0	64.0	82.0	61.0	79.0	95.0
	kW	7.3	7.2	7.1	7.2	7.1	7.1	7.5	7.3	7.3
85	TC	101.0	86.0	79.0	107.0	96.0	85.0	111.0	100.0	90.0
	SHC	40.0	48.0	63.0	47.0	63.0	77.0	54.0	73.0	88.0
	kW	8.0	7.8	7.8	8.1	8.0	7.9	8.1	8.0	7.9
95	TC	93.0	82.0	73.0	99.0	88.0	78.0	103.0	92.0	84.0
	SHC	33.0	46.0	58.0	40.0	56.0	71.0	47.0	66.0	77.0
	kW	8.7	8.6	8.5	8.8	8.7	8.6	8.9	8.7	8.6
105	TC	85.0	75.0	66.0	90.0	80.0	71.0	94.0	83.0	75.0
	SHC	27.0	40.0	52.0	33.0	50.0	65.0	40.0	60.0	74.0
	kW	9.5	9.4	9.3	9.6	9.5	9.4	9.7	9.5	9.4
115	TC	77.0	68.0	59.0	81.0	72.0	63.0	85.0	75.0	69.0
	SHC	21.0	33.0	46.0	26.0	43.0	59.0	33.0	53.0	62.0
	kW	10.4	10.3	10.2	10.5	10.4	10.3	10.5	10.4	10.3
125	TC	69.0	60.0	51.0	73.0	64.0	56.0	75.0	66.0	60.0
	SHC	14.0	27.0	40.0	20.0	37.0	52.0	25.0	46.0	58.0
	kW	11.4	11.3	11.2	11.5	11.4	11.3	11.5	11.4	11.3

RGF/RAF102 — Unit with Hot Gas Re-Heat System in Hot Gas Reheat Mode — Cooling Capacities

TEMP (°F) AIR ENTERING CONDENSER (Edb)		AIR ENTERING EVAPORATOR — Ewb (°F)								
		75 Dry Bulb 62.5 Wet Bulb (50% Relative)			75 Dry Bulb 64 Wet Bulb (56% Relative)			75 Dry Bulb 65.3 Wet Bulb (60% Relative)		
		Air Entering Evaporator — cfm								
		2550	3400	4250	2550	3400	4250	2550	3400	4250
80	TC	36.0	39.0	41.0	37.0	40.0	430.0	38.0	42.0	44.0
	SHC	7.0	14.0	22.0	2.0	8.0	155.0	-2.0	3.0	9.0
	kW	6.2	6.2	6.2	6.3	6.3	6.2	6.3	6.3	6.3
75	TC	38.0	41.0	43.0	39.0	43.0	45.0	41.0	44.0	46.0
	SHC	8.0	16.0	24.0	4.0	11.0	17.0	0.0	6.0	12.0
	kW	5.4	5.4	5.4	5.4	5.5	5.5	5.6	5.6	5.7
70	TC	40.0	43.0	46.0	41.0	45.0	47.0	43.0	46.0	48.0
	SHC	10.0	18.0	26.0	6.0	13.0	19.0	2.0	8.0	14.0
	kW	5.2	5.2	5.2	5.2	5.2	5.2	5.2	5.2	5.2
60	TC	44.0	48.0	50.0	46.0	49.0	52.0	47.0	50.0	53.0
	SHC	14.0	22.0	30.0	9.0	16.0	23.0	5.0	11.0	17.0
	kW	5.2	5.1	5.1	5.1	5.1	5.1	5.1	5.1	5.1
50	TC	48.0	52.0	54.0	50.0	54.0	56.0	51.0	55.0	57.0
	SHC	17.0	26.0	34.0	13.0	20.0	27.0	9.0	15.0	21.0
	kW	5.1	5.1	5.1	5.1	5.1	5.1	5.1	5.1	5.1
40	TC	52.0	56.0	58.0	54.0	58.0	60.0	55.0	59.0	62.0
	SHC	21.0	30.0	38.0	16.0	24.0	31.0	12.0	19.0	25.0
	kW	5.1	5.1	5.1	5.1	5.1	5.1	5.1	5.1	5.0

LEGEND

Edb	—	Entering Dry Bulb
Ewb	—	Entering Wet Bulb
kW	—	Compressor Power Input
SCFM/BF	—	Standard Cubic Feet per Minute/Bypass Factor
SHC	—	Sensible Heat Capacity (1000 Btuh) Gross
TC	—	Total Capacity (1000 Btuh) Gross

Performance data (cont)

RGF/RAF120 Two-Stage Cooling Capacities

RGF/RAF120			AMBIENT TEMPERATURE (°F)																
			85			95			105			115			125				
			EA (db)			EA (db)			EA (db)			EA (db)			EA (db)				
			75	80	85	75	80	85	75	80	85	75	80	85	75	80	85		
3000 cfm	EA (wb)	58	TC	106.2	106.2	120.5	100.9	100.9	114.7	95.3	95.3	108.4	89.3	89.3	101.8	82.9	82.9	94.9	
			SHC	92.0	106.2	120.5	87.2	100.9	114.7	82.1	95.3	108.4	76.8	89.3	101.8	71.1	82.9	94.9	
		62	TC	112.7	112.7	112.8	106.2	106.2	109.0	99.3	99.3	105.0	91.9	91.9	100.8	84.3	84.3	96.5	
			SHC	82.2	97.5	112.8	78.4	93.7	109.0	74.5	89.7	105.0	70.3	85.6	100.8	66.1	81.3	96.5	
		67	TC	124.5	124.5	124.5	117.4	117.4	117.4	110.0	110.0	110.0	102.0	102.0	102.0	93.8	93.8	93.8	
			SHC	67.4	82.7	98.0	63.6	78.9	94.2	59.7	75.0	90.3	55.6	70.9	86.3	51.4	66.7	82.1	
	72	TC	137.3	137.3	137.3	129.8	129.8	129.8	121.7	121.7	121.7	113.1	113.1	113.1	—	—	—		
		SHC	52.3	67.6	82.9	48.5	63.8	79.2	44.6	59.9	75.2	40.6	55.9	71.2	—	—	—		
	76	TC	—	148.3	148.3	—	140.2	140.2	—	131.7	131.7	—	122.6	122.6	—	—	—		
		SHC	—	55.3	70.2	—	51.5	66.5	—	47.6	62.6	—	43.5	58.5	—	—	—		
	3500 cfm	EA (wb)	58	TC	112.9	112.9	127.8	107.2	107.2	121.6	101.2	101.2	115.0	94.8	94.8	108.0	88.0	88.0	100.5
				SHC	97.9	112.9	127.8	92.7	107.2	121.6	87.3	101.2	115.0	81.6	94.8	108.0	75.5	88.0	100.5
62			TC	116.7	116.7	124.6	109.9	109.9	120.7	102.7	102.7	116.6	95.2	95.2	111.9	88.2	88.2	104.8	
			SHC	89.3	107.0	124.6	85.4	103.1	120.7	81.3	99.0	116.6	77.0	94.4	111.9	71.4	88.2	104.8	
67			TC	128.4	128.4	128.4	121.1	121.1	121.1	113.3	113.3	113.3	105.0	105.0	105.0	96.4	96.4	96.4	
			SHC	71.9	89.7	107.4	68.1	85.9	103.6	64.1	81.8	99.6	59.9	77.7	95.5	55.8	73.4	91.2	
72		TC	141.4	141.4	141.4	133.4	133.4	133.4	125.0	125.0	125.0	116.2	116.2	116.2	—	—	—		
		SHC	54.2	71.9	89.7	50.4	68.1	85.9	46.4	64.1	81.9	42.3	60.0	77.7	—	—	—		
76		TC	—	152.5	152.5	—	144.0	144.0	—	135.1	135.1	—	125.7	125.7	—	—	—		
		SHC	—	57.5	74.9	—	53.6	71.0	—	49.6	67.1	—	45.5	63.0	—	—	—		
4000 cfm		EA (wb)	58	TC	118.4	118.4	134.0	112.4	112.4	127.5	106.0	106.0	120.5	99.3	99.3	113.1	92.2	92.2	105.2
				SHC	102.7	118.4	134.0	97.4	112.4	127.5	91.7	106.0	120.5	85.6	99.3	113.1	79.2	92.2	105.2
	62		TC	120.0	120.0	135.9	113.1	113.1	131.5	107.0	107.0	123.1	99.5	99.5	117.7	92.3	92.3	109.6	
			SHC	96.0	115.9	135.9	91.9	111.7	131.5	85.9	104.5	123.1	81.1	99.5	117.7	75.0	92.3	109.6	
	67		TC	131.6	131.6	131.6	123.9	123.9	123.9	115.8	115.8	115.8	107.3	107.3	107.3	98.4	98.4	100.0	
			SHC	76.2	96.4	116.6	72.3	92.5	112.7	68.3	88.4	108.6	64.1	84.3	104.3	59.9	80.0	100.0	
	72	TC	144.5	144.5	144.5	136.2	136.2	136.2	127.6	127.6	127.6	118.4	118.4	118.4	—	—	—		
		SHC	55.9	76.0	96.2	52.0	72.1	92.2	48.0	68.1	88.3	43.8	63.9	84.1	—	—	—		
	76	TC	—	155.6	155.6	—	146.9	146.9	—	137.7	137.7	—	128.0	128.0	—	—	—		
		SHC	—	59.4	79.1	—	55.5	75.2	—	51.5	71.3	—	47.3	67.2	—	—	—		
	4500 cfm	EA (wb)	58	TC	123.0	123.0	139.3	116.8	116.8	132.3	110.1	110.1	125.0	103.1	103.1	117.2	95.7	95.7	109.1
				SHC	106.9	123.0	139.3	101.3	116.8	132.3	95.3	110.1	125.0	88.9	103.1	117.2	82.3	95.7	109.1
62			TC	125.3	125.3	138.0	119.2	119.2	129.7	110.3	110.3	130.2	103.2	103.2	122.2	95.8	95.8	113.6	
			SHC	98.3	118.2	138.0	92.2	111.0	129.7	90.3	110.3	130.2	84.3	103.2	122.2	77.9	95.8	113.6	
67			TC	134.0	134.0	134.0	126.2	126.2	126.2	117.8	117.8	117.8	109.1	109.1	113.1	100.0	100.0	108.7	
			SHC	80.4	102.9	125.4	76.4	98.9	121.4	72.4	94.8	117.3	68.2	90.6	113.1	63.9	86.4	108.7	
72		TC	147.0	147.0	147.0	138.5	138.5	138.5	129.6	129.6	129.6	120.2	120.2	120.2	—	—	—		
		SHC	57.4	79.9	102.4	53.4	75.9	98.4	49.4	71.9	94.4	45.2	67.7	90.3	—	—	—		
76		TC	—	158.1	158.1	—	149.1	149.1	—	139.7	139.7	—	129.7	129.7	—	—	—		
		SHC	—	61.1	83.2	—	57.2	79.2	—	53.1	75.2	—	48.9	71.1	—	—	—		
5000 cfm		EA (wb)	58	TC	127.0	127.0	143.7	120.6	120.6	136.5	113.7	113.7	129.0	106.3	106.3	120.8	98.6	98.6	112.3
				SHC	110.4	127.0	143.7	104.5	120.6	136.5	98.3	113.7	129.0	91.8	106.3	120.8	84.9	98.6	112.3
	62		TC	127.2	127.2	149.4	120.7	120.7	142.0	113.8	113.8	134.2	106.4	106.4	125.8	98.7	98.7	117.0	
			SHC	105.0	127.2	149.4	99.3	120.7	142.0	93.4	113.8	134.2	87.0	106.4	125.8	80.4	98.7	117.0	
	67		TC	135.9	135.9	135.9	128.0	128.0	130.1	119.5	119.5	125.9	110.6	110.6	121.5	—	—	—	
			SHC	84.4	109.2	134.0	80.4	105.2	130.1	76.4	101.1	125.9	72.1	96.8	121.5	—	—	—	
	72	TC	148.9	148.9	148.9	140.2	140.2	140.2	131.1	131.1	131.1	121.6	121.6	121.6	—	—	—		
		SHC	58.7	83.6	108.4	54.8	79.6	104.5	50.7	75.5	100.4	46.6	71.3	96.1	—	—	—		
	76	TC	—	160.1	160.1	—	150.9	150.9	—	141.2	141.2	—	131.1	131.1	—	—	—		
		SHC	—	62.6	87.0	—	58.7	83.1	—	54.6	79.0	—	50.4	74.9	—	—	—		

LEGEND

- — Do Not Operate
- cfm — Cubic Feet Per Minute (Supply Air)
- EA (db) — Entering Air Temperature (dry bulb)
- EA (wb) — Entering Air Temperature (wet bulb)
- SHC — Sensible Heat Capacity (1000 Btuh) Gross
- TC — Total Capacity (1000 Btuh) Gross

NOTE: See minimum-maximum airflow ratings on page 8.

Performance data (cont)

RGF/RAF120 Single-Stage Cooling Capacities

RGF/RAF120			AMBIENT TEMPERATURE (°F)																
			85			95			105			115			125				
			EA (db)			EA (db)			EA (db)			EA (db)			EA (db)				
			75	80	85	75	80	85	75	80	85	75	80	85	75	80	85		
			1800 cfm	EA (wb)	58	TC	60.0	60.0	68.4	56.3	56.3	64.4	52.4	52.4	60.2	48.3	48.3	55.7	44.0
SHC	51.6	60.0				68.4	48.2	56.3	64.4	44.7	52.4	60.2	40.9	48.3	55.7	36.9	44.0	51.0	
62	TC	62.6			62.6	66.5	58.2	58.2	63.6	53.6	53.6	60.7	48.7	48.7	57.5	44.0	44.0	53.4	
	SHC	47.0			56.7	66.5	44.1	53.9	63.6	41.2	50.9	60.7	38.1	47.8	57.5	34.6	44.0	53.4	
67	TC	70.0			70.0	70.0	65.2	65.2	65.2	60.2	60.2	60.2	55.0	55.0	55.0	49.5	49.5	49.5	
	SHC	38.1			47.8	57.6	35.2	45.0	54.8	32.3	42.1	51.8	29.3	39.1	48.8	26.2	36.0	45.8	
72	TC	77.9		77.9	77.9	72.9	72.9	72.9	67.6	67.6	67.6	62.0	62.0	62.0	56.1	56.1	56.1		
	SHC	29.0		38.8	48.5	26.1	35.9	45.7	23.2	33.0	42.8	20.2	30.0	39.8	17.2	26.9	36.7		
76	TC	—		84.8	84.8	—	79.5	79.5	—	73.9	73.9	—	68.0	68.0	—	61.7	61.7		
	SHC	—		31.4	41.0	—	28.5	38.2	—	25.6	35.3	—	22.6	32.3	—	19.6	29.2		
2100 cfm	EA (wb)	58		TC	64.1	64.1	72.9	60.1	60.1	68.6	56.0	56.0	64.2	51.7	51.7	59.4	47.0	47.0	54.3
				SHC	55.2	64.1	72.9	51.6	60.1	68.6	47.8	56.0	64.2	43.9	51.7	59.4	39.6	47.0	54.3
		62	TC	65.0	65.0	74.1	60.4	60.4	71.1	56.1	56.1	67.0	51.7	51.7	62.1	47.1	47.1	56.9	
			SHC	51.6	62.9	74.1	48.6	59.8	71.1	45.1	56.1	67.0	41.3	51.7	62.1	37.2	47.1	56.9	
		67	TC	72.3	72.3	72.3	67.3	67.3	67.3	62.1	62.1	62.1	56.7	56.7	56.7	50.9	50.9	51.7	
			SHC	41.1	52.5	63.8	38.2	49.5	60.9	35.2	46.6	57.9	32.2	43.5	54.9	29.0	40.4	51.7	
	72	TC	80.2	80.2	80.2	75.0	75.0	75.0	69.5	69.5	69.5	63.7	63.7	63.7	57.6	57.6	57.6		
		SHC	30.3	41.7	53.1	27.5	38.8	50.2	24.5	35.9	47.2	21.5	32.8	44.2	18.3	29.7	41.1		
	76	TC	—	87.2	87.2	—	81.6	81.6	—	75.8	75.8	—	69.7	69.7	—	63.3	63.3		
		SHC	—	33.0	44.2	—	30.1	41.3	—	27.1	38.4	—	24.1	35.4	—	21.0	32.3		
	2400 cfm	EA (wb)	58	TC	67.5	67.5	76.7	63.3	63.3	72.2	59.0	59.0	67.5	54.4	54.4	62.5	49.5	49.5	57.2
				SHC	58.2	67.5	76.7	54.4	63.3	72.2	50.5	59.0	67.5	46.3	54.4	62.5	41.9	49.5	57.2
62			TC	67.5	67.5	79.9	63.4	63.4	75.2	59.0	59.0	70.4	54.5	54.5	65.4	49.5	49.5	59.7	
			SHC	55.2	67.5	79.9	51.5	63.4	75.2	47.7	59.0	70.4	43.7	54.5	65.4	39.3	49.5	59.7	
67			TC	74.0	74.0	74.0	68.9	68.9	68.9	63.5	63.5	63.9	58.0	58.0	60.8	52.1	52.1	57.5	
			SHC	44.0	56.9	69.8	41.0	53.9	66.9	38.0	50.9	63.9	34.9	47.8	60.8	31.8	44.7	57.5	
72		TC	82.0	82.0	82.0	76.6	76.6	76.6	70.9	70.9	70.9	65.0	65.0	65.0	58.7	58.7	58.7		
		SHC	31.6	44.5	57.5	28.7	41.6	54.6	25.7	38.6	51.5	22.6	35.5	48.5	19.4	32.4	45.3		
76		TC	—	89.0	89.0	—	83.2	83.2	—	77.3	77.3	—	71.0	71.0	—	64.4	64.4		
		SHC	—	34.5	47.3	—	31.5	44.3	—	28.6	41.4	—	25.5	38.3	—	22.3	35.2		
2700 cfm		EA (wb)	58	TC	70.3	70.3	79.9	66.0	66.0	75.2	61.5	61.5	70.3	56.7	56.7	65.1	51.6	51.6	59.4
				SHC	60.8	70.3	79.9	56.9	66.0	75.2	52.7	61.5	70.3	48.4	56.7	65.1	43.7	51.6	59.4
	62		TC	70.5	70.5	83.2	66.1	66.1	78.4	61.6	61.6	73.3	56.8	56.8	68.0	51.7	51.7	62.2	
			SHC	57.7	70.5	83.2	53.9	66.1	78.4	49.9	61.6	73.3	45.6	56.8	68.0	41.2	51.7	62.2	
	67		TC	75.3	75.3	75.6	70.1	70.1	72.7	64.7	64.7	69.6	59.0	59.0	66.5	53.0	53.0	63.2	
			SHC	46.7	61.2	75.6	43.7	58.2	72.7	40.7	55.2	69.6	37.6	52.0	66.5	34.4	48.8	63.2	
	72	TC	83.4	83.4	83.4	77.8	77.8	77.8	72.0	72.0	72.0	65.9	65.9	65.9	59.5	59.5	59.5		
		SHC	32.7	47.2	61.7	29.8	44.3	58.8	26.7	41.2	55.7	23.6	38.1	52.6	20.5	34.9	49.4		
	76	TC	—	90.3	90.3	—	84.5	84.5	—	78.4	78.4	—	72.0	72.0	—	65.2	65.2		
		SHC	—	35.8	50.1	—	32.9	47.2	—	29.9	44.2	—	26.8	41.2	—	23.6	38.0		
	3000 cfm	EA (wb)	58	TC	72.8	72.8	82.6	68.3	68.3	77.7	63.6	63.6	72.6	58.6	58.6	67.2	53.4	53.4	61.4
				SHC	63.0	72.8	82.6	58.8	68.3	77.7	54.6	63.6	72.6	50.1	58.6	67.2	45.3	53.4	61.4
62			TC	72.8	72.8	85.9	68.4	68.4	81.0	63.7	63.7	75.7	58.7	58.7	70.1	53.4	53.4	64.2	
			SHC	59.7	72.8	85.9	55.8	68.4	81.0	51.6	63.7	75.7	47.3	58.7	70.1	42.6	53.4	64.2	
67			TC	76.4	76.4	81.3	71.2	71.2	78.4	65.6	65.6	75.2	59.9	59.9	71.9	53.9	53.9	68.4	
			SHC	49.4	65.3	81.3	46.4	62.4	78.4	43.3	59.3	75.2	40.2	56.1	71.9	36.9	52.6	68.4	
72		TC	84.5	84.5	84.5	78.8	78.8	78.8	72.9	72.9	72.9	66.7	66.7	66.7	60.2	60.2	60.2		
		SHC	33.7	49.8	65.8	30.8	46.8	62.9	27.8	43.8	59.8	24.6	40.7	56.7	21.4	37.4	53.4		
76		TC	—	91.4	91.4	—	85.5	85.5	—	79.3	79.3	—	72.8	72.8	—	—	—		
		SHC	—	37.1	52.9	—	34.1	50.0	—	31.1	47.0	—	28.0	43.9	—	—	—		

LEGEND

- — Do Not Operate
- cfm — Cubic Feet Per Minute (Supply Air)
- EA (db) — Entering Air Temperature (dry bulb)
- EA (wb) — Entering Air Temperature (wet bulb)
- SHC — Sensible Heat Capacity (1000 Btuh) Gross
- TC — Total Capacity (1000 Btuh) Gross

NOTE: See minimum-maximum airflow ratings on page 8.

Performance data (cont)

RGF/RAF120 — Unit with Hot Gas Re-Heat System in Subcooling Mode — Cooling Capacities

TEMP (°F) AIR ENTERING CONDENSER (Edb)		AIR ENTERING EVAPORATOR — SCFM/BF (80°F db)								
		3000/0.06			4000/0.08			5000/0.10		
		Air Entering Evaporator — Ewb (°F)								
		72	67	62	72	67	62	72	67	62
75	TC	137.0	124.0	111.0	147.0	132.0	120.0	147.0	135.0	129.0
	SHC	58.0	78.0	97.0	72.0	96.0	117.0	78.0	110.0	125.0
	kW	9.6	9.4	9.2	9.8	9.6	9.4	9.8	9.7	9.6
85	TC	128.0	116.0	103.0	135.0	123.0	112.0	140.0	127.0	118.0
	SHC	51.0	72.0	89.0	61.0	88.0	109.0	72.0	104.0	118.0
	kW	10.4	10.3	10.0	10.6	10.4	10.2	10.7	10.5	10.3
95	TC	117.0	107.0	96.0	124.0	111.0	101.0	128.0	117.0	110.0
	SHC	41.0	63.0	83.0	52.0	77.0	98.0	62.0	95.0	110.0
	kW	11.3	11.1	10.9	11.4	11.2	11.0	11.5	11.3	11.2
105	TC	110.0	98.0	87.0	117.0	104.0	95.0	120.0	104.0	99.0
	SHC	35.0	55.0	76.0	46.0	72.0	89.0	55.0	83.0	99.0
	kW	12.3	12.1	11.9	12.5	12.2	12.0	12.6	12.2	12.2
115	TC	101.0	89.0	78.0	106.0	92.0	84.0	109.0	96.0	92.0
	SHC	28.0	48.0	68.0	37.0	61.0	82.0	46.0	77.0	92.0
	kW	13.4	13.2	13.0	13.6	13.3	13.1	13.6	13.4	13.3
125	TC	92.0	79.0	69.0	95.0	81.0	75.0	98.0	87.0	81.0
	SHC	20.0	39.0	60.0	28.0	52.0	74.0	37.0	69.0	81.0
	kW	14.7	14.4	14.2	14.8	14.4	14.3	14.8	14.6	14.5

RGF/RAF120 — Unit with Hot Gas Re-Heat System in Hot Gas Reheat Mode — Cooling Capacities

TEMP (°F) AIR ENTERING CONDENSER (Edb)		AIR ENTERING EVAPORATOR — Ewb (°F)								
		75 Dry Bulb 62.5 Wet Bulb (50% Relative)			75 Dry Bulb 64 Wet Bulb (56% Relative)			75 Dry Bulb 65.3 Wet Bulb (60% Relative)		
		Air Entering Evaporator — cfm								
		3000	4000	5000	3000	4000	5000	3000	4000	5000
80	TC	45.0	49.0	52.0	46.0	51.0	53.0	48.0	52.0	54.0
	SHC	7.0	16.0	25.0	2.0	9.0	17.0	-3.0	4.0	10.0
	kW	7.4	7.6	7.7	7.6	7.7	7.7	7.7	7.8	7.8
75	TC	47.0	52.0	54.0	49.0	53.0	56.0	50.0	54.0	57.0
	SHC	9.0	18.0	28.0	4.0	12.0	20.0	0.0	7.0	14.0
	kW	6.8	6.9	6.9	6.9	6.9	7.0	7.0	7.1	7.1
70	TC	50.0	54.0	57.0	51.0	56.0	59.0	53.0	57.0	60.0
	SHC	11.0	20.0	30.0	5.0	14.0	22.0	2.0	8.0	15.0
	kW	6.7	6.7	6.7	6.7	6.7	6.7	6.7	6.8	6.8
60	TC	54.0	59.0	62.0	56.0	61.0	64.0	58.0	62.0	65.0
	SHC	15.0	25.0	35.0	9.0	18.0	26.0	5.0	12.0	19.0
	kW	6.6	6.6	6.7	6.6	6.7	6.7	6.7	6.7	6.7
50	TC	59.0	64.0	67.0	61.0	66.0	69.0	63.0	68.0	71.0
	SHC	19.0	29.0	39.0	13.0	22.0	31.0	9.0	16.0	24.0
	kW	6.6	6.6	6.6	6.6	6.6	6.6	6.6	6.6	6.6
40	TC	63.0	69.0	72.0	66.0	71.0	74.0	67.0	73.0	76.0
	SHC	23.0	33.0	44.0	17.0	26.0	35.0	13.0	20.0	28.0
	kW	6.6	6.6	6.6	6.6	6.6	6.6	6.6	6.6	6.6

LEGEND

- Edb — Entering Dry Bulb
- Ewb — Entering Wet Bulb
- kW — Compressor Power Input
- SCFM/BF — Standard Cubic Feet per Minute/Bypass Factor
- SHC — Sensible Heat Capacity (1000 Btuh) Gross
- TC — Total Capacity (1000 Btuh) Gross

Performance data (cont)

RGF/RAF150 Two-Stage Cooling Capacities

RGF/RAF150			AMBIENT TEMPERATURE (°F)														
			85			95			105			115					
			EA (db)			EA (db)			EA (db)			EA (db)					
3750 cfm	EA (wb)	58	75	80	85	75	80	85	75	80	85	75	80	85			
						TC	132.4	132.4	150.1	126.1	126.1	143.2	119.3	119.3	135.8	112.1	112.1
			SHC	114.7	132.4	150.1	109.0	126.1	143.2	102.9	119.3	135.8	96.4	112.1	127.8		
		62	TC	140.5	140.5	151.5	131.2	131.2	138.8	122.8	122.8	134.1	114.1	114.1	129.1		
			SHC	110.5	131.0	151.5	99.0	118.9	138.8	94.3	114.2	134.1	89.4	109.2	129.1		
		67	TC	153.2	153.2	153.2	144.9	144.9	144.9	136.2	136.2	136.2	126.4	126.4	126.4		
			SHC	83.5	103.4	123.3	79.1	99.0	118.9	74.5	94.4	114.3	69.6	89.5	109.4		
		72	TC	169.3	169.3	169.3	160.1	160.1	160.1	150.7	150.7	150.7	140.1	140.1	140.1		
			SHC	63.7	83.2	102.7	59.1	78.7	98.3	54.5	74.1	93.8	49.5	69.2	88.9		
		76	TC	—	182.8	182.8	—	172.9	172.9	—	163.0	163.0	—	151.9	151.9		
			SHC	—	66.4	87.0	—	62.0	79.2	—	57.5	75.7	—	52.7	71.4		
4400 cfm	EA (wb)	58	TC	140.5	140.5	159.1	133.8	133.8	151.7	126.6	126.6	143.9	118.9	118.9	135.3		
			SHC	121.9	140.5	159.1	115.8	133.8	151.7	109.3	126.6	143.9	102.4	118.9	135.3		
		62	TC	143.9	143.9	159.2	135.8	135.8	154.2	127.2	127.2	148.6	120.7	120.7	136.0		
			SHC	113.0	136.1	159.2	108.2	131.2	154.2	103.1	125.8	148.6	94.6	115.3	136.0		
		67	TC	157.9	157.9	157.9	149.2	149.2	149.2	140.3	140.3	140.3	130.0	130.0	130.0		
			SHC	89.3	112.4	135.6	84.7	107.9	131.1	80.2	103.4	126.6	75.2	98.4	121.7		
		72	TC	173.9	173.9	173.9	164.5	164.5	164.5	154.5	154.5	154.5	143.8	143.8	143.8		
			SHC	65.4	88.2	111.1	60.8	83.7	106.6	56.0	79.0	102.0	51.1	74.1	97.1		
		76	TC	—	187.8	187.8	—	177.6	177.6	—	167.0	167.0	—	155.7	155.7		
			SHC	—	68.6	89.8	—	64.0	85.7	—	59.4	81.4	—	54.5	76.8		
		5000 cfm	EA (wb)	58	TC	146.8	146.8	166.2	139.7	139.7	158.3	132.1	132.1	150.0	123.9	123.9	141.0
					SHC	127.5	146.8	166.2	121.0	139.7	158.3	114.2	132.1	150.0	106.9	123.9	141.0
				62	TC	147.6	147.6	171.2	143.0	143.0	153.9	132.3	132.3	156.2	124.1	124.1	146.9
					SHC	120.3	145.8	171.2	109.6	131.8	153.9	108.3	132.3	156.2	101.3	124.1	146.9
67	TC			161.7	161.7	161.7	152.4	152.4	152.4	143.0	143.0	143.0	132.6	132.6	132.7		
	SHC			94.4	120.5	146.7	89.7	115.9	142.1	85.1	111.3	137.5	80.3	106.5	132.7		
72	TC			177.6	177.6	177.6	167.7	167.7	167.7	157.5	157.5	157.5	146.4	146.4	146.4		
	SHC			66.6	92.5	118.4	61.9	87.9	113.8	57.1	83.1	109.1	52.1	78.2	104.2		
76	TC			—	191.4	191.4	—	180.9	180.9	—	170.4	170.4	—	158.4	158.4		
	SHC			—	69.8	94.6	—	65.2	90.2	—	60.6	85.8	—	55.5	80.9		
5650 cfm	EA (wb)	58	TC	152.6	152.6	172.6	145.1	145.1	164.4	137.1	137.1	155.6	128.6	128.6	146.2		
			SHC	132.6	152.6	172.6	125.8	145.1	164.4	118.7	137.1	155.6	111.0	128.6	146.2		
		62	TC	153.8	153.8	176.2	145.3	145.3	171.1	137.3	137.3	162.0	128.8	128.8	152.3		
			SHC	124.3	150.3	176.2	119.5	145.3	171.1	112.6	137.3	162.0	105.2	128.8	152.3		
		67	TC	164.4	164.4	164.4	155.2	155.2	155.2	146.1	146.1	148.3	134.7	134.7	144.2		
			SHC	99.5	128.9	158.2	95.0	124.4	153.8	89.4	118.8	148.3	85.6	114.9	144.2		
		72	TC	180.9	180.9	180.9	170.8	170.8	170.8	159.9	159.9	159.9	148.6	148.6	148.6		
			SHC	67.5	96.6	125.8	62.8	92.0	121.1	57.9	87.1	116.3	52.9	82.2	111.4		
		76	TC	—	194.8	194.8	—	184.2	184.2	—	172.5	172.5	—	160.7	160.7		
			SHC	—	70.5	98.6	—	65.9	94.2	—	60.9	89.4	—	55.9	84.5		
6250 cfm	EA (wb)	58	TC	157.2	157.2	177.8	149.5	149.5	169.2	141.2	141.2	160.1	132.3	132.3	150.4		
			SHC	136.6	157.2	177.8	129.7	149.5	169.2	122.2	141.2	160.1	114.3	132.3	150.4		
		62	TC	157.4	157.4	184.8	149.6	149.6	176.0	141.3	141.3	166.6	132.2	132.2	156.3		
			SHC	129.9	157.4	184.8	123.2	149.6	176.0	116.0	141.3	166.6	108.2	132.2	156.3		
		67	TC	168.3	168.3	171.9	157.1	157.1	164.1	147.0	147.0	159.5	136.4	136.4	154.5		
			SHC	107.6	139.8	171.9	99.7	131.9	164.1	95.2	127.3	159.5	90.4	122.5	154.5		
		72	TC	182.9	182.9	182.9	172.6	172.6	172.6	161.7	161.7	161.7	150.3	150.3	150.3		
			SHC	67.7	99.8	131.9	63.0	95.1	127.3	58.2	90.4	122.5	53.3	85.5	117.6		
		76	TC	—	197.6	197.6	—	185.9	185.9	—	174.5	174.5	—	163.0	163.0		
			SHC	—	70.5	101.6	—	65.5	96.8	—	60.6	92.0	—	55.6	87.1		

LEGEND

- Do Not Operate
- cfm — Cubic Feet Per Minute (Supply Air)
- EA (db) — Entering Air Temperature (dry bulb)
- EA (wb) — Entering Air Temperature (wet bulb)
- SHC — Sensible Heat Capacity (1000 Btuh) Gross
- TC — Total Capacity (1000 Btuh) Gross

NOTE: See minimum-maximum airflow ratings on page 8.

Performance data (cont)

RGF/RAF150 Single-Stage Cooling Capacities

RGF/RAF150				AMBIENT TEMPERATURE (°F)												
				85			95			105			115			
				EA (db)			EA (db)			EA (db)			EA (db)			
				75	80	85	75	80	85	75	80	85	75	80	85	
2500 cfm	EA (wb)	58	TC	71.2	71.2	80.8	66.9	66.9	76.1	62.2	62.2	71.1	57.2	57.2	65.6	
			SHC	61.5	71.2	80.8	57.6	66.9	76.1	53.4	62.2	71.1	48.9	57.2	65.6	
		62	TC	74.1	74.1	78.5	68.9	68.9	75.4	63.3	63.3	72.0	58.5	58.5	65.4	
			SHC	56.0	67.3	78.5	52.9	64.1	75.4	49.6	60.8	72.0	44.8	55.1	65.4	
		67	TC	82.4	82.4	82.4	76.8	76.8	76.8	69.9	69.9	69.9	64.2	64.2	64.2	
			SHC	45.4	56.7	68.0	42.3	53.6	64.8	38.8	49.9	61.1	35.6	46.7	57.8	
	72	TC	91.5	91.5	91.5	85.3	85.3	85.3	78.7	78.7	78.7	71.7	71.7	71.7		
		SHC	34.7	46.0	57.2	31.6	42.8	54.1	28.3	39.5	50.7	25.0	36.0	47.0		
	76	TC	—	99.3	99.3	—	92.6	92.6	—	85.6	85.6	—	78.0	78.0		
		SHC	—	37.2	48.5	—	34.1	45.4	—	30.8	42.0	—	27.3	38.0		
	2900 cfm	EA (wb)	58	TC	77.2	77.2	87.5	72.4	72.4	82.3	67.3	67.3	76.7	61.8	61.8	70.7
				SHC	66.8	77.2	87.5	62.5	72.4	82.3	57.9	67.3	76.7	53.0	61.8	70.7
62			TC	79.0	79.0	87.0	72.5	72.5	85.8	67.4	67.4	80.0	61.9	61.9	73.7	
			SHC	61.6	74.3	87.0	59.3	72.5	85.8	54.9	67.4	80.0	50.1	61.9	73.7	
67			TC	85.8	85.8	85.8	79.7	79.7	79.7	73.3	73.3	73.3	66.4	66.4	67.1	
			SHC	50.0	63.7	77.5	46.8	60.6	74.3	43.5	57.2	70.8	40.0	53.6	67.1	
72		TC	95.0	95.0	95.0	88.4	88.4	88.4	81.3	81.3	81.3	72.7	72.7	72.7		
		SHC	36.6	50.3	64.1	33.4	47.2	60.9	30.1	43.8	57.5	23.9	37.4	50.9		
76		TC	—	102.9	102.9	—	95.8	95.8	—	88.3	88.3	—	80.4	80.4		
		SHC	—	39.5	53.2	—	36.3	50.0	—	33.0	46.7	—	29.4	42.8		
3300 cfm		EA (wb)	58	TC	81.4	81.4	92.3	76.4	76.4	86.7	70.9	70.9	80.7	64.7	64.7	73.8
				SHC	70.6	81.4	92.3	66.0	76.4	86.7	61.1	70.9	80.7	55.5	64.7	73.8
	62		TC	81.5	81.5	96.0	76.5	76.5	90.3	71.0	71.0	84.1	65.1	65.1	77.4	
			SHC	67.0	81.5	96.0	62.6	76.5	90.3	57.9	71.0	84.1	52.8	65.1	77.4	
	67		TC	87.9	87.9	87.9	81.5	81.5	82.5	74.9	74.9	79.1	67.8	67.8	75.3	
			SHC	53.8	69.8	85.7	50.6	66.6	82.5	47.3	63.2	79.1	43.8	59.5	75.3	
	72	TC	97.2	97.2	97.2	90.3	90.3	90.3	83.1	83.1	83.1	75.1	75.1	75.1		
		SHC	38.1	54.0	70.0	34.8	50.8	66.7	31.5	47.4	63.4	27.9	43.7	59.4		
	76	TC	—	105.1	105.1	—	97.8	97.8	—	90.1	90.1	—	—	—		
		SHC	—	41.2	57.1	—	38.0	53.9	—	34.6	50.5	—	—	—		
	3700 cfm	EA (wb)	58	TC	85.0	85.0	96.3	79.6	79.6	90.4	73.9	73.9	84.1	67.7	67.7	77.2
				SHC	73.7	85.0	96.3	68.9	79.6	90.4	63.8	73.9	84.1	58.2	67.7	77.2
62			TC	85.1	85.1	100.2	79.7	79.7	94.1	74.0	74.0	87.5	67.6	67.6	80.3	
			SHC	70.1	85.1	100.2	65.4	79.7	94.1	60.4	74.0	87.5	54.9	67.6	80.3	
67			TC	89.4	89.4	93.9	83.0	83.0	90.6	76.1	76.1	87.2	68.8	68.8	83.4	
			SHC	57.6	75.7	93.9	54.4	72.5	90.6	51.1	69.2	87.2	47.5	65.5	83.4	
72		TC	98.8	98.8	98.8	91.8	91.8	91.8	84.3	84.3	84.3	76.4	76.4	76.4		
		SHC	39.5	57.6	75.8	36.1	54.3	72.4	32.8	50.9	69.1	29.3	47.3	65.3		
76		TC	—	106.7	106.7	—	—	—	—	—	—	—	—	—		
		SHC	—	42.8	60.9	—	—	—	—	—	—	—	—	—		

LEGEND

—	Do Not Operate
cfm	Cubic Feet Per Minute (Supply Air)
EA (db)	Entering Air Temperature (dry bulb)
EA (wb)	Entering Air Temperature (wet bulb)
SHC	Sensible Heat Capacity (1000 Btuh) Gross
TC	Total Capacity (1000 Btuh) Gross

NOTE: See minimum-maximum airflow ratings on page 8.

Performance data (cont)

RGF/RAF150 — Unit with Hot Gas Re-Heat System in Subcooling Mode — Cooling Capacities

TEMP (°F) AIR ENTERING CONDENSER (Edb)		AIR ENTERING EVAPORATOR — SCFM/BF (80°F db)								
		3750/0.11			5000/0.13			6250/0.15		
		Air Entering Evaporator — Ewb (°F)								
		72	67	62	72	67	62	72	67	62
75	TC	157.0	140.0	127.0	165.0	150.0	135.0	172.0	156.0	141.0
	SHC	64.0	82.0	101.0	74.0	99.0	122.0	85.0	114.0	138.0
	kW	12.4	12.0	11.8	12.6	12.3	12.0	12.8	12.4	12.1
85	TC	137.0	132.0	118.0	144.0	141.0	127.0	151.0	132.0	133.0
	SHC	46.0	75.0	93.0	55.0	91.0	114.0	66.0	92.0	129.0
	kW	13.0	13.1	12.8	13.2	13.4	13.0	13.4	12.9	13.2
95	TC	137.0	122.0	110.0	145.0	129.0	117.0	150.0	134.0	123.0
	SHC	47.0	66.0	86.0	57.0	80.0	105.0	66.0	95.0	120.0
	kW	14.7	14.3	14.0	14.9	14.5	14.2	15.0	14.6	14.3
105	TC	127.0	113.0	103.0	134.0	120.0	108.0	139.0	125.0	114.0
	SHC	39.0	58.0	74.0	48.0	73.0	97.0	56.0	86.0	110.0
	kW	15.9	15.6	15.3	16.1	15.8	15.5	16.3	15.9	15.6
115	TC	116.0	103.0	94.0	123.0	110.0	98.0	127.0	114.0	103.0
	SHC	29.0	50.0	66.0	38.0	64.0	89.0	46.0	76.0	102.0
	kW	17.3	16.9	11.7	17.5	17.1	16.8	17.6	17.2	16.9

RGF/RAF150 — Unit with Hot Gas Re-Heat System in Hot Gas Reheat Mode — Cooling Capacities

TEMP (°F) AIR ENTERING CONDENSER (Edb)		AIR ENTERING EVAPORATOR — Ewb (°F)								
		75 Dry Bulb 62.5 Wet Bulb (50% Relative)			75 Dry Bulb 64 Wet Bulb (56% Relative)			75 Dry Bulb 65.3 Wet Bulb (60% Relative)		
		Air Entering Evaporator — cfm								
		3750	5000	6250	3750	5000	6250	3750	5000	6250
80	TC	54.0	59.0	62.0	56.0	61.0	64.0	58.0	63.0	66.0
	SHC	9.0	20.0	31.0	3.0	12.0	21.0	-3.0	5.0	13.0
	kW	10.9	11.0	11.1	11.0	11.1	11.1	11.0	11.1	11.2
75	TC	57.0	62.0	65.0	60.0	65.0	68.0	62.0	67.0	70.0
	SHC	13.0	24.0	35.0	7.0	16.0	25.0	2.0	9.0	17.0
	kW	10.5	10.6	10.6	10.6	10.6	10.7	10.6	10.7	10.8
70	TC	61.0	66.0	69.0	63.0	68.0	72.0	66.0	71.0	74.0
	SHC	17.0	28.0	39.0	12.0	21.0	30.0	7.0	15.0	22.0
	kW	10.1	10.2	10.3	10.2	10.3	10.3	10.2	10.3	10.4
60	TC	62.0	67.0	70.0	64.0	69.0	72.0	66.0	71.0	74.0
	SHC	16.0	27.0	38.0	10.0	19.0	28.0	4.0	12.0	20.0
	kW	11.0	11.3	11.5	11.1	11.4	11.6	11.3	11.5	11.7
50	TC	69.0	74.0	77.0	71.0	76.0	80.0	73.0	79.0	82.0
	SHC	23.0	34.0	45.0	17.0	26.0	35.0	11.0	19.0	27.0
	kW	10.2	10.4	10.6	10.3	10.5	10.7	10.4	10.7	10.8
40	TC	75.0	80.0	84.0	78.0	83.0	87.0	80.0	86.0	89.0
	SHC	31.0	41.0	52.0	25.0	34.0	43.0	19.0	27.0	35.0
	kW	9.4	9.7	9.8	9.6	9.8	10.0	9.7	9.9	10.1

LEGEND

Ewb	—	Entering wet bulb
kW	—	compressor Power Input
SCFM/BF	—	Standard Cubic Feet per Minute/Bypass Factor
SHC	—	Sensible Heat Capacity (1000 Btuh) Gross
TC	—	Total Capacity (1000 Btuh) Gross

NOTE: See minimum-maximum airflow ratings on page 8.

Performance data (cont)

RGF/RAF180 Two-Stage Cooling Capacities (cont)

RGF/RAF180			AMBIENT TEMPERATURE (°F)																
			85			95			105			115			125				
			EA (db)			EA (db)			EA (db)			EA (db)			EA (db)				
			75	80	85	75	80	85	75	80	85	75	80	85	75	80	85		
7150 cfm	EA (wb)	58	TC	184.3	184.3	208.7	174.6	174.6	198.1	164.7	164.7	187.3	154.0	154.0	175.6	142.6	142.6	163.1	
			SHC	159.9	184.3	208.7	151.0	174.6	198.1	142.1	164.7	187.3	132.4	154.0	175.6	122.1	142.6	163.1	
		62	TC	185.4	185.4	216.0	179.1	179.1	189.9	167.9	167.9	183.0	154.2	154.2	183.0	142.8	142.8	170.1	
			SHC	151.4	183.7	216.0	135.4	162.6	189.9	128.7	155.8	183.0	125.3	154.2	183.0	115.4	142.8	170.1	
		67	TC	202.1	202.1	202.1	190.3	190.3	190.3	177.8	177.8	177.8	164.8	164.8	164.9	151.0	151.0	157.7	
			SHC	118.4	151.9	185.3	112.1	145.4	178.8	105.5	138.7	172.0	98.7	131.8	164.9	91.8	124.7	157.7	
	72	TC	221.3	221.3	221.3	208.6	208.6	208.6	195.3	195.3	195.3	181.2	181.2	181.2	166.7	166.7	166.7		
		SHC	83.0	116.4	149.8	76.6	109.9	143.3	70.0	103.3	136.6	63.2	96.4	129.6	56.3	89.4	122.5		
	76	TC	—	237.6	237.6	—	224.2	224.2	—	210.0	210.0	—	195.1	195.1	—	179.7	179.7		
		SHC	—	87.4	119.9	—	80.9	113.4	—	74.2	106.7	—	67.4	99.8	—	60.3	92.6		
	7500 cfm	EA (wb)	58	TC	187.0	187.0	211.7	177.3	177.3	201.1	167.0	167.0	189.9	156.1	156.1	178.0	144.9	144.9	165.4
				SHC	162.2	187.0	211.7	153.4	177.3	201.1	144.1	167.0	189.9	134.3	156.1	178.0	124.3	144.9	165.4
62			TC	191.3	191.3	203.3	181.7	181.7	191.1	167.2	167.2	197.7	156.2	156.2	185.4	144.7	144.7	172.4	
			SHC	145.7	174.5	203.3	136.5	163.8	191.1	136.6	167.2	197.7	127.1	156.2	185.4	117.1	144.7	172.4	
67			TC	203.5	203.5	203.5	191.6	191.6	191.6	179.0	179.0	179.0	165.9	165.9	169.7	152.0	152.0	162.5	
			SHC	120.7	155.4	190.2	114.3	149.0	183.6	107.7	142.3	176.8	100.9	135.3	169.7	94.0	128.3	162.5	
72		TC	222.7	222.7	222.7	209.9	209.9	209.9	196.4	196.4	196.4	182.3	182.3	182.3	167.6	167.6	167.6		
		SHC	83.4	118.1	152.9	77.0	111.7	146.4	70.4	105.0	139.6	63.6	98.1	132.7	56.7	91.1	125.5		
76		TC	—	239.0	239.0	—	225.4	225.4	—	211.2	211.2	—	196.1	196.1	—	180.6	180.6		
		SHC	—	87.7	121.5	—	81.1	114.9	—	74.4	108.2	—	67.5	101.2	—	60.4	94.0		

LEGEND

—	Do Not Operate
cfm	Cubic Feet Per Minute (Supply Air)
EA (db)	Entering Air Temperature (dry bulb)
EA (wb)	Entering Air Temperature (wet bulb)
SHC	Sensible Heat Capacity (1000 Btuh) Gross
TC	Total Capacity (1000 Btuh) Gross

NOTE: See minimum-maximum airflow ratings on page 8.

Performance data (cont)

RGF/RAF180 Single-Stage Cooling Capacities (cont)

RGF/RAF180			AMBIENT TEMPERATURE (°F)																
			85			95			105			115			125				
			EA (db)			EA (db)			EA (db)			EA (db)			EA (db)				
			75	80	85	75	80	85	75	80	85	75	80	85	75	80	85		
3900 Cfm	EA (wb)	58	TC	115.0	115.0	130.7	108.5	108.5	123.7	101.6	101.6	116.2	94.4	94.4	108.4	86.8	86.8	100.1	
			SHC	99.3	115.0	130.7	93.3	108.5	123.7	87.0	101.6	116.2	80.5	94.4	108.4	73.5	86.8	100.1	
		62	TC	118.3	118.3	129.9	110.7	110.7	124.8	102.9	102.9	119.2	94.7	94.7	113.4	86.9	86.9	104.7	
			SHC	91.6	110.7	129.9	86.6	105.7	124.8	81.4	100.3	119.2	75.9	94.7	113.4	69.1	86.9	104.7	
		67	TC	130.8	130.8	130.8	122.7	122.7	122.7	114.1	114.1	114.1	105.1	105.1	105.1	95.6	95.6	95.6	
			SHC	73.3	92.6	112.0	68.4	87.8	107.1	63.5	82.7	102.0	58.3	77.6	96.8	53.1	72.3	91.5	
	72	TC	144.3	144.3	144.3	135.7	135.7	135.7	126.6	126.6	126.6	116.7	116.7	116.7	106.8	106.8	106.8		
		SHC	54.4	73.7	92.9	49.6	68.9	88.1	44.7	63.9	83.1	39.5	58.7	77.9	34.3	53.5	72.7		
	76	TC	—	155.9	155.9	—	146.8	146.8	—	137.3	137.3	—	127.3	127.3	—	116.7	116.7		
		SHC	—	58.2	76.8	—	53.4	72.0	—	48.5	67.1	—	43.4	62.1	—	38.2	56.9		
	4150 Cfm	EA (wb)	58	TC	117.6	117.6	133.6	111.0	111.0	126.4	104.0	104.0	118.8	96.6	96.6	110.9	88.6	88.6	102.1
				SHC	101.6	117.6	133.6	95.5	111.0	126.4	89.1	104.0	118.8	82.4	96.6	110.9	75.1	88.6	102.1
62			TC	119.9	119.9	134.9	112.3	112.3	129.5	104.3	104.3	124.2	96.7	96.7	115.7	88.9	88.9	107.0	
			SHC	94.6	114.8	134.9	89.5	109.5	129.5	84.4	104.3	124.2	77.7	96.7	115.7	70.8	88.9	107.0	
67			TC	132.3	132.3	132.3	124.1	124.1	124.1	115.4	115.4	115.4	106.2	106.2	106.2	96.6	96.6	96.6	
			SHC	75.3	95.8	116.2	70.5	90.9	111.3	65.5	85.8	106.2	60.3	80.6	100.9	55.0	75.2	95.5	
72		TC	145.8	145.8	145.8	137.1	137.1	137.1	127.8	127.8	127.8	118.0	118.0	118.0	107.9	107.9	107.9		
		SHC	55.2	75.6	95.9	50.4	70.7	91.1	45.4	65.7	86.0	40.2	60.5	80.8	35.0	55.3	75.5		
76		TC	—	157.5	157.5	—	148.2	148.2	—	138.6	138.6	—	128.5	128.5	—	117.7	117.7		
		SHC	—	59.1	78.8	—	54.3	73.9	—	49.3	69.0	—	44.3	64.0	—	39.0	58.7		

LEGEND

—	Do Not Operate
cfm	Cubic Feet Per Minute (Supply Air)
EA (db)	Entering Air Temperature (dry bulb)
EA (wb)	Entering Air Temperature (wet bulb)
SHC	Sensible Heat Capacity (1000 Btuh) Gross
TC	Total Capacity (1000 Btuh) Gross

NOTE: See minimum-maximum airflow ratings on page 8.

Performance data (cont)

RGF/RAF180 — Unit with Hot Gas Re-Heat System in Subcooling Mode — Cooling Capacities

TEMP (°F) AIR ENTERING CONDENSER (Edb)		AIR ENTERING EVAPORATOR — SCFM/BF (80°F db)								
		4500/0.09			6000/0.12			7500/0.14		
		Air Entering Evaporator — Ewb (°F)								
		72	67	62	72	67	62	72	67	62
75	TC	203.0	181.0	162.0	213.0	196.0	175.0	225.0	202.0	183.0
	SHC	82.0	103.0	124.0	93.0	125.0	152.0	109.0	142.0	175.0
	kW	14.1	13.7	13.4	14.2	14.1	13.7	14.5	14.1	13.8
85	TC	190.0	168.0	149.0	202.0	181.0	161.0	210.0	189.0	169.0
	SHC	70.0	91.0	113.0	83.0	112.0	139.0	95.0	130.0	162.0
	kW	15.3	14.9	14.6	15.5	15.2	14.8	15.7	15.3	14.9
95	TC	176.0	155.0	137.0	187.0	166.0	148.0	195.0	174.0	155.0
	SHC	57.0	79.0	102.0	70.0	98.0	127.0	81.0	117.0	149.0
	kW	16.6	16.2	15.9	16.9	16.5	16.1	17.0	16.7	16.3
105	TC	161.0	141.0	124.0	172.0	152.0	134.0	179.0	159.0	141.0
	SHC	44.0	67.0	90.0	56.0	85.0	114.0	67.0	103.0	135.0
	kW	18.1	17.7	17.4	18.4	17.9	17.6	18.5	18.1	17.8
115	TC	146.0	127.0	110.0	156.0	137.0	120.0	162.0	143.0	126.0
	SHC	31.0	54.0	78.0	42.0	73.0	101.0	52.0	89.0	121.0
	kW	19.8	19.4	19.1	20.0	19.7	19.3	20.2	19.8	19.4
125	TC	130.0	113.0	97.0	139.0	121.0	105.0	145.0	127.0	110.0
	SHC	18.0	42.0	65.0	28.0	59.0	88.0	37.0	75.0	106.0
	kW	21.6	21.2	20.8	21.8	21.4	21.0	21.9	21.6	21.1

RGF/RAF180 — Unit with Hot Gas Re-Heat System in Hot Gas Reheat Mode — Cooling Capacities

TEMP (°F) AIR ENTERING CONDENSER (Edb)		AIR ENTERING EVAPORATOR — Ewb (°F)								
		75 Dry Bulb 62.5 Wet Bulb (50% Relative)			75 Dry Bulb 64 Wet Bulb (56% Relative)			75 Dry Bulb 65.3 Wet Bulb (60% Relative)		
		Air Entering Evaporator — cfm								
		4500	6000	7500	4500	6000	7500	4500	6000	7500
80	TC	60.0	63.0	65.0	64.0	66.0	68.0	67.0	68.0	70.0
	SHC	9.0	5.0	2.0	16.0	11.0	7.0	22.0	16.0	11.0
	kW	12.8	12.8	12.9	12.9	12.9	13.0	12.9	13.0	13.0
75	TC	63.0	66.0	68.0	67.0	69.0	71.0	70.0	72.0	74.0
	SHC	12.0	8.0	4.0	19.0	14.0	9.0	25.0	19.0	13.0
	kW	12.5	12.5	12.6	12.6	12.6	12.6	12.6	12.6	12.6
70	TC	66.0	69.0	71.0	70.0	73.0	74.0	73.0	75.0	77.0
	SHC	14.0	10.0	7.0	22.0	16.0	12.0	28.0	21.0	16.0
	kW	12.4	12.4	12.5	12.5	12.5	12.5	12.5	12.5	12.5
60	TC	72.0	74.0	77.0	76.0	79.0	80.0	79.0	81.0	83.0
	SHC	21.0	15.0	11.0	26.0	21.0	17.0	33.0	26.0	21.0
	kW	12.4	12.4	12.4	12.4	12.4	12.4	12.4	12.4	12.4
50	TC	77.0	80.0	82.0	82.0	84.0	86.0	85.0	87.0	89.0
	SHC	24.0	19.0	16.0	31.0	26.0	22.0	38.0	32.0	26.0
	kW	12.4	12.4	12.4	12.4	12.4	12.4	12.4	12.4	12.4
40	TC	82.0	85.0	87.0	87.0	90.0	92.0	90.0	92.0	95.0
	SHC	28.0	24.0	20.0	36.0	31.0	27.0	43.0	37.0	31.0
	kW	12.4	12.4	12.4	12.4	12.4	12.4	12.4	12.4	12.4

LEGEND

Edb	—	Entering dry bulb
Ewb	—	Entering wet bulb
kW	—	compressor Power Input
SCFM/BF	—	Standard Cubic Feet per Minute/Bypass Factor
SHC	—	Sensible Heat Capacity (1000 Btu/h) Gross
TC	—	Total Capacity (1000 Btu/h) Gross

Performance data (cont)

Pressure Drops for Electric Heating Units

7.5 and 8.5 Ton Units

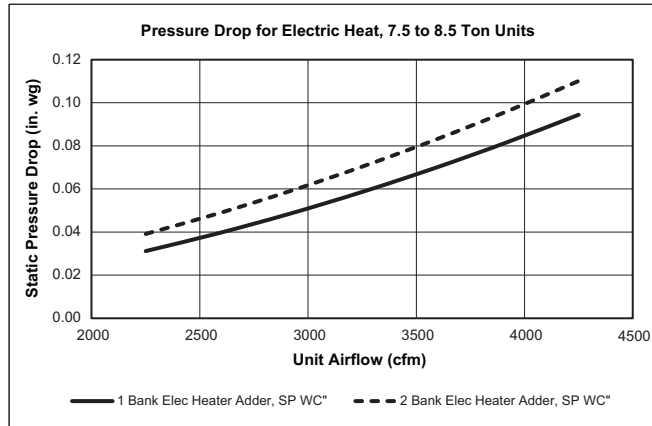

10 and 12.5 Ton Units

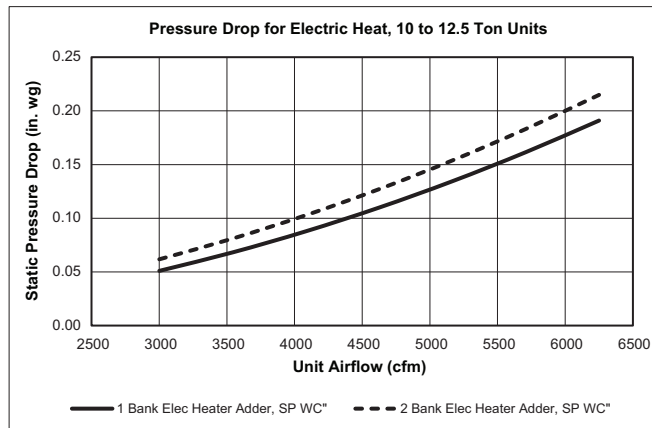

15 Ton Units

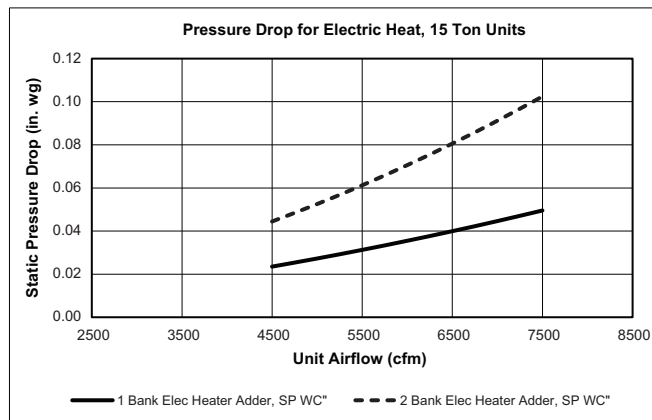

Performance data (cont)

Pressure Drops For Gas Heating Units

Gas Heat Stages

RGF UNIT SIZE	HEAT SIZE		
	LOW	MEDIUM	HIGH
090	1	2	2
102	1	2	2
120	2	2	2
150	2	2	2
180	2	2	2

Gas Heat Static Pressure Deductions (in. wg) — 7.5 To 8.5 Ton Units

CFM	2250	2585	2915	3250	3585	3915	4250
MEDIUM GAS HEAT DEDUCTION	0.01	0.01	0.02	0.04	0.05	0.06	0.08
LOW GAS HEAT DEDUCTION	0.11	0.13	0.16	0.19	0.22	0.26	0.29

Gas Heat Static Pressure Deductions (in. wg) — 10 To 12.5 Ton Units

CFM	3000	3540	4085	4625	5165	5710	6250
MEDIUM GAS HEAT DEDUCTION	-0.03	0.00	0.04	0.08	0.13	0.20	0.27
LOW GAS HEAT DEDUCTION	0.17	0.24	0.31	0.40	0.49	0.59	0.71

Gas Heat Static Pressure Deductions (in. wg) — 15 Ton Units

CFM	4500	5000	5500	6000	6500	7000	7500
HIGH GAS HEAT DEDUCTION	0.21	0.24	0.26	0.29	0.31	0.34	0.36
MEDIUM GAS HEAT DEDUCTION	0.20	0.22	0.25	0.27	0.29	0.32	0.34
LOW GAS HEAT DEDUCTION	0.33	0.37	0.42	0.48	0.53	0.59	0.65

Performance data (cont)

Field-installed Accessory Electric Heater Data

RAF UNIT SIZE	VOLTAGE	HEATER MODEL NUMBER	HEAT STAGES
090	208/230	CRHEATER411A00	1
		CRHEATER412A00	1
		CRHEATER414A00	2
		CRHEATER415A00	2
		CRHEATER416A00	2
	460	CRHEATER420A00	1
		CRHEATER421A00	2
		CRHEATER422A00	2
		CRHEATER423A00	2
		CRHEATER425A00	1
575	CRHEATER427A00	2	
	CRHEATER411A00	1	
102	208/230	CRHEATER412A00	1
		CRHEATER414A00	2
		CRHEATER415A00	2
		CRHEATER416A00	2
		CRHEATER417A00	2
	460	CRHEATER420A00	1
		CRHEATER421A00	2
		CRHEATER422A00	2
		CRHEATER423A00	2
		CRHEATER425A00	1
575	CRHEATER427A00	2	
	CRHEATER411A00	1	
120	208/230	CRHEATER412A00	1
		CRHEATER415A00	2
		CRHEATER416A00	2
		CRHEATER417A00	2
		CRHEATER420A00	1
	460	CRHEATER422A00	2
		CRHEATER423A00	2
		CRHEATER424A00	2
		CRHEATER425A00	1
		CRHEATER427A00	2
575	CRHEATER428A00	2	
	CRHEATER411A00	1	
150	208/230	CRHEATER412A00	1
		CRHEATER415A00	2
		CRHEATER416A00	2
		CRHEATER417A00	2
		CRHEATER420A00	1
	460	CRHEATER422A00	2
		CRHEATER423A00	2
		CRHEATER424A00	2
		CRHEATER425A00	2
		CRHEATER427A00	2
575	CRHEATER428A00	2	
	CRHEATER412A00	1	
180	208/230	CRHEATER414A00	2
		CRHEATER415A00	2
		CRHEATER416A00	2
		CRHEATER417A00	2
		CRHEATER451A00	2
		CRHEATER420A00	1
	460	CRHEATER421A00	2
		CRHEATER422A00	2
		CRHEATER423A00	2
		CRHEATER424A00	2
575	CRHEATER452A00	1	
	CRHEATER425A00	1	
	CRHEATER427A00	2	
	CRHEATER428A00	2	
	CRHEATER453A00	2	
	CRHEATER429A00	2	

Performance data (cont)

Economizer Barometric Relief and Damper Leakage — 7.5 to 12.5 Ton Units

Horizontal Economizer Barometric Relief

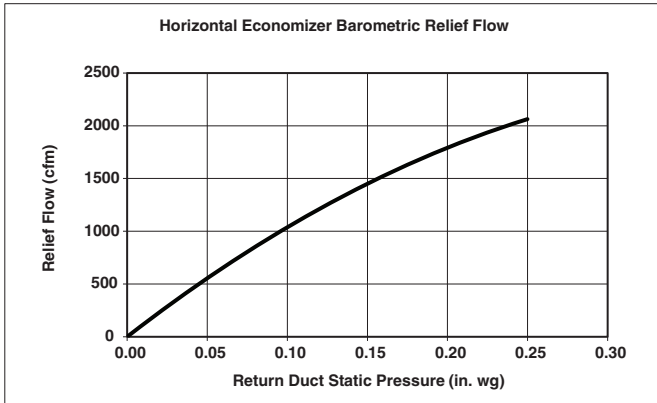

Vertical Economizer Barometric Relief

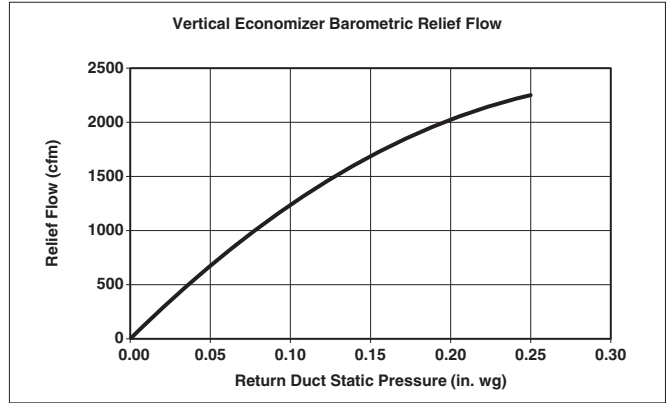

Horizontal Economizer Damper Leakage

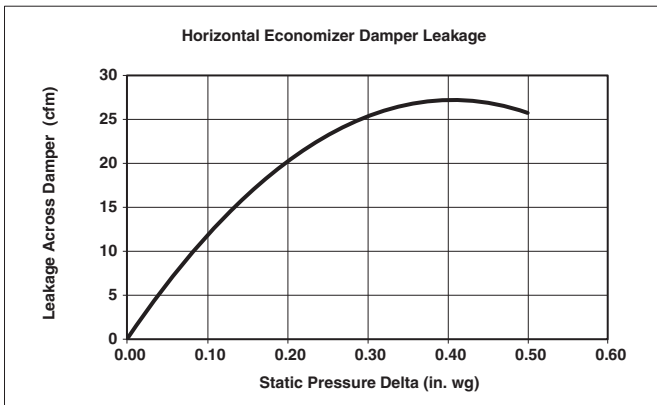

Vertical Economizer Damper Leakage

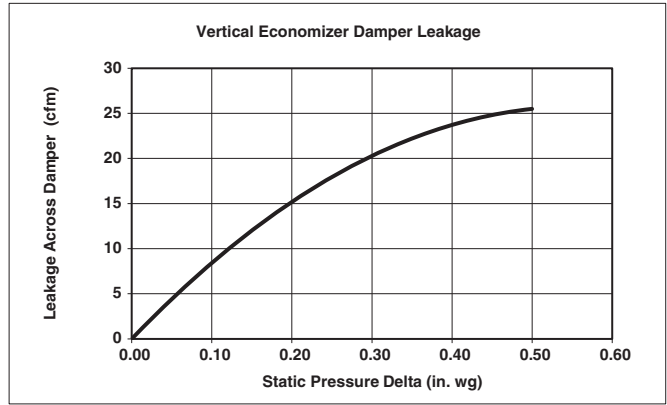

Performance data (cont)

Economizer Barometric Relief and Damper Leakage — 15 Ton Units

Horizontal Economizer Barometric Relief

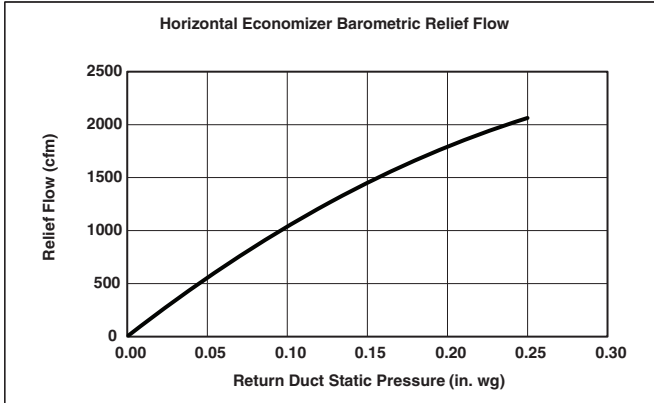

Vertical Economizer Barometric Relief

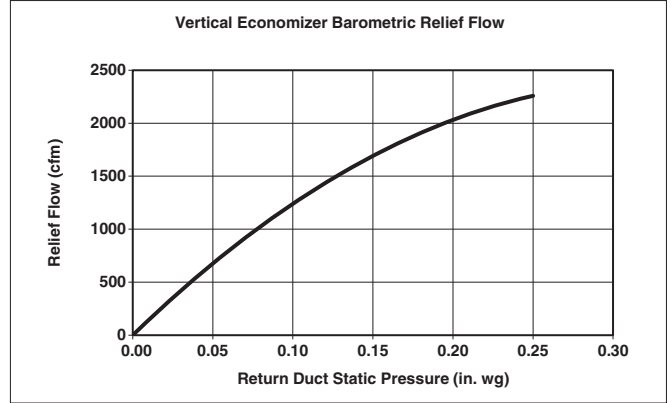

Horizontal Economizer Damper Leakage

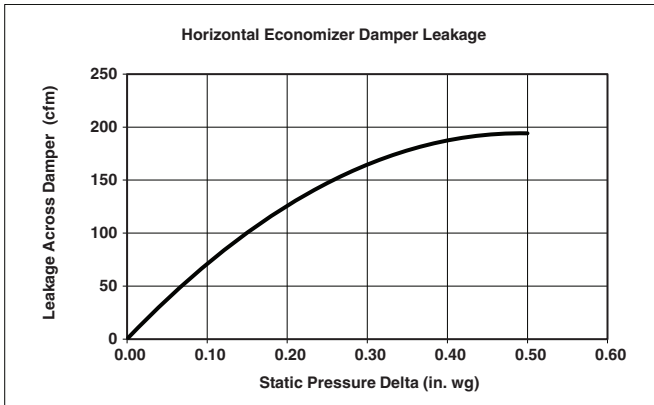

Vertical Economizer Damper Leakage

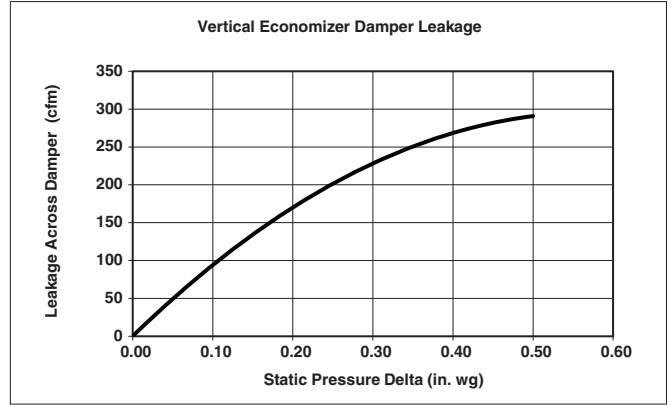

Economizer Pressure Drop

7.5 to 12.5 Ton Units

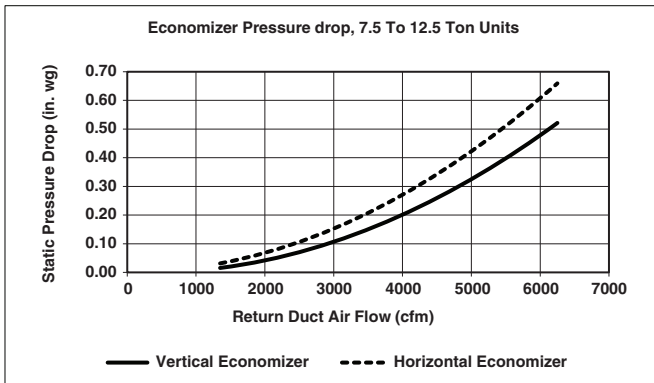

15 Ton Units

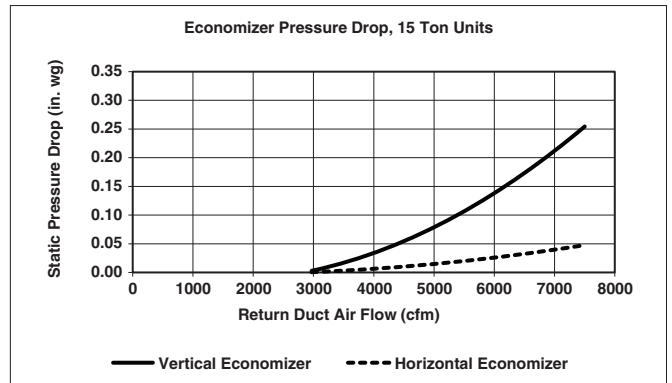

Performance data (cont)

Hot Gas Re-Heat Coil Pressure Drops — 7.5 to 15 Ton Units

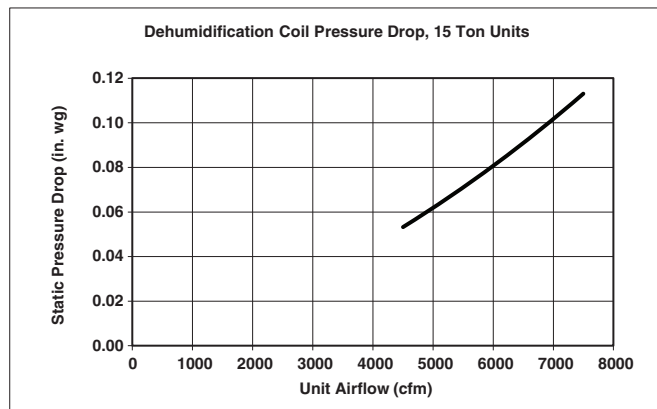
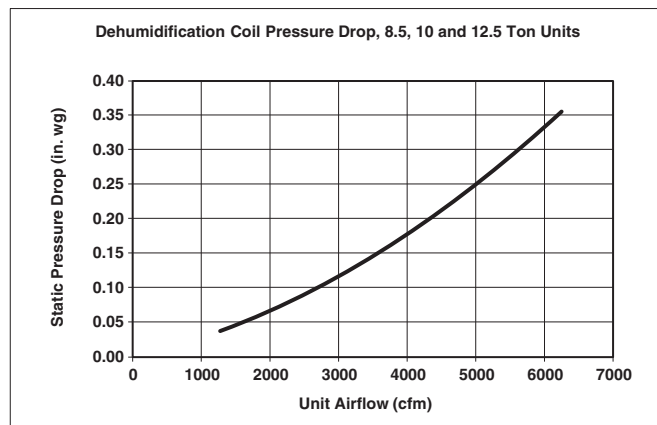
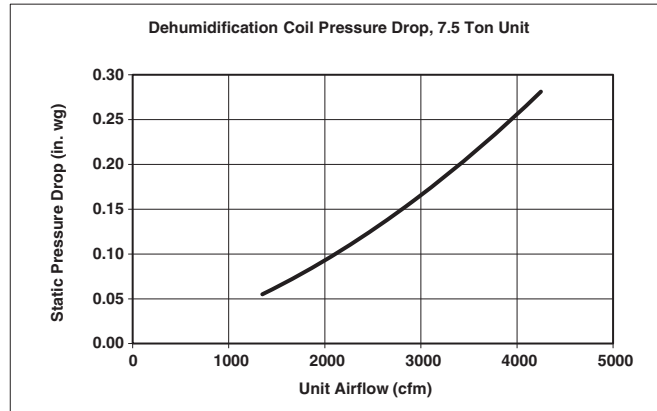

Fan data

General Fan Performance Notes

1. Interpolation is permissible. Do not extrapolate.
2. External static pressure is the static pressure difference between the return duct and the supply duct plus the static pressure caused by any FIOPs or accessories.
3. Tabular data accounts for pressure loss due to clean filters, unit casing, wet coils, and highest gas heat exchanger (when gas heat unit).
4. Factory options and accessories may effect static pressure losses. Gas heat unit fan tables assume highest gas heat models; for fan selections with low or medium heat models, the user must deduct low and medium heat static pressures. Selection software is available, through your salesperson, to help you select the best motor/drive combination for your application.
5. The fan performance tables offer motor/drive recommendations. In cases when two motor/drive combinations would work, the lower horsepower option is recommended.
6. For information on the electrical properties of the fan motors, please see the Electrical information section of this book.
7. For more information on the performance limits of the fan motors, see the application data section of this book.
8. The EPACT (Energy Policy Act of 1992) regulates energy requirements for specific types of indoor fan motors. Motors regulated by EPACT include any general purpose, T-frame (three-digit, 143 and larger), single-speed, foot mounted, polyphase, squirrel cage induction motors of NEMA (National Electrical Manufacturers Association) design A and B, manufactured for use in the United States. Ranging from 1 to 200 Hp, these continuous-duty motors operate on 230 and 460 volt, 60 Hz power. If a motor does not fit into these specifications, the motor does not have to be replaced by an EPACT compliant energy-efficient motor. Variable-speed motors are exempt from EPACT compliance requirements.

Fan data (cont)

RGF090 — 7.5 Ton Vertical Supply (rpm - bhp)

CFM	AVAILABLE EXTERNAL STATIC PRESSURE (in. wg)									
	0.2		0.4		0.6		0.8		1.0	
	rpm	bhp	rpm	bhp	rpm	bhp	rpm	bhp	rpm	bhp
2250	1045	0.43	1166	0.60	1273	0.78	1372	0.97	1463	1.18
2440	1111	0.51	1226	0.69	1329	0.88	1424	1.08	1512	1.30
2625	1178	0.61	1288	0.80	1387	1.00	1478	1.21	1564	1.43
2815	1246	0.72	1351	0.91	1446	1.12	1534	1.34	1617	1.57
3000	1314	0.83	1415	1.04	1507	1.26	1592	1.48	1672	1.71
3190	1383	0.96	1480	1.17	1568	1.40	1651	1.63	1729	1.87
3375	1453	1.09	1545	1.31	1631	1.55	1711	1.78	1786	2.03
3565	1523	1.23	1612	1.46	1694	1.70	1772	1.94	1845	2.20
3750	1594	1.38	1679	1.62	1759	1.86	1834	2.11	1905	2.36

CFM	AVAILABLE EXTERNAL STATIC PRESSURE (in. wg)									
	1.2		1.4		1.6		1.8		2.0	
	rpm	bhp	rpm	bhp	rpm	bhp	rpm	bhp	rpm	bhp
2250	1548	1.40	1629	1.63	1706	1.87	1778	2.12	1848	2.38
2440	1595	1.52	1674	1.76	1749	2.01	1821	2.27	1889	2.53
2625	1645	1.66	1721	1.90	1794	2.16	1865	2.42	1932	2.69
2815	1696	1.81	1770	2.06	1842	2.32	1910	2.58	1976	2.86
3000	1748	1.96	1821	2.22	1891	2.48	1958	2.75	2022	3.03
3190	1803	2.12	1873	2.38	1941	2.65	2007	2.93	—	—
3375	1858	2.29	1927	2.55	1994	2.83	2058	3.11	—	—
3565	1915	2.45	1982	2.72	2047	3.00	—	—	—	—
3750	1973	2.62	2039	2.90	2102	3.17	—	—	—	—

Std/Med Static 1045-2000 rpm, 2.4 maximum bhp

High Static 1045-2200 rpm, 3.0 maximum bhp

RGF090 — Standard/Medium Static — 7.5 Ton Vertical Supply (rpm - vdc)

CFM	AVAILABLE EXTERNAL STATIC PRESSURE (in. wg)									
	0.2		0.4		0.6		0.8		1.0	
	rpm	vdc	rpm	vdc	rpm	vdc	rpm	vdc	rpm	vdc
2250	1045	5.1	1166	5.7	1273	6.3	1372	6.8	1463	7.2
2440	1111	5.4	1226	6.0	1329	6.5	1424	7.0	1512	7.5
2625	1178	5.8	1288	6.3	1387	6.8	1478	7.3	1564	7.8
2815	1246	6.1	1351	6.7	1446	7.2	1534	7.6	1617	8.0
3000	1314	6.5	1415	7.0	1507	7.5	1592	7.9	1672	8.3
3190	1383	6.8	1480	7.3	1568	7.8	1651	8.2	1729	8.6
3375	1453	7.2	1545	7.7	1631	8.1	1711	8.5	1786	8.9
3565	1523	7.5	1612	8.0	1694	8.4	1772	8.8	1845	9.2
3750	1594	7.9	1679	8.3	1759	8.8	1834	9.1	1905	9.5

CFM	AVAILABLE EXTERNAL STATIC PRESSURE (in. wg)									
	1.2		1.4		1.6		1.8		2.0	
	rpm	vdc	rpm	vdc	rpm	vdc	rpm	vdc	rpm	vdc
2250	1548	7.7	1629	8.1	1706	8.5	1778	8.9	1848	9.2
2440	1595	7.9	1674	8.3	1749	8.7	1821	9.1	—	—
2625	1645	8.2	1721	8.6	1794	8.9	—	—	—	—
2815	1696	8.4	1770	8.8	1842	9.2	—	—	—	—
3000	1748	8.7	1821	9.1	—	—	—	—	—	—
3190	1803	9.0	1873	9.3	—	—	—	—	—	—
3375	1858	9.3	—	—	—	—	—	—	—	—
3565	—	—	—	—	—	—	—	—	—	—
3750	—	—	—	—	—	—	—	—	—	—

Std/Med Static 1045-2000 rpm

Fan data (cont)

RGF090 — High Static — 7.5 Ton Vertical Supply (rpm - vdc)

CFM	AVAILABLE EXTERNAL STATIC PRESSURE (in. wg)									
	0.2		0.4		0.6		0.8		1.0	
	rpm	vdc	rpm	vdc	rpm	vdc	rpm	vdc	rpm	vdc
2250	1045	4.7	1166	5.2	1273	5.7	1372	6.2	1463	6.6
2440	1111	5.0	1226	5.5	1329	6.0	1424	6.4	1512	6.8
2625	1178	5.3	1288	5.8	1387	6.2	1478	6.7	1564	7.1
2815	1246	5.6	1351	6.1	1446	6.5	1534	6.9	1617	7.3
3000	1314	5.9	1415	6.4	1507	6.8	1592	7.2	1672	7.6
3190	1383	6.2	1480	6.7	1568	7.1	1651	7.5	1729	7.8
3375	1453	6.6	1545	7.0	1631	7.4	1711	7.7	1786	8.1
3565	1523	6.9	1612	7.3	1694	7.7	1772	8.0	1845	8.4
3750	1594	7.2	1679	7.6	1759	8.0	1834	8.3	1905	8.6

CFM	AVAILABLE EXTERNAL STATIC PRESSURE (in. wg)									
	1.2		1.4		1.6		1.8		2.0	
	rpm	vdc	rpm	vdc	rpm	vdc	rpm	vdc	rpm	vdc
2250	1548	7.0	1629	7.4	1706	7.7	1778	8.1	1848	8.4
2440	1595	7.2	1674	7.6	1749	7.9	1821	8.3	1889	8.6
2625	1645	7.4	1721	7.8	1794	8.1	1865	8.5	1932	8.8
2815	1696	7.7	1770	8.0	1842	8.3	1910	8.7	1976	9.0
3000	1748	7.9	1821	8.3	1891	8.6	1958	8.9	2022	9.2
3190	1803	8.2	1873	8.5	1941	8.8	2007	9.1	—	—
3375	1858	8.4	1927	8.7	1994	9.0	2058	9.3	—	—
3565	1915	8.7	1982	9.0	2047	9.3	—	—	—	—
3750	1973	9.0	2039	9.3	2102	9.5	—	—	—	—

High Static 1045-2200 rpm

Fan data (cont)

RGF102 — 8.5 Ton Vertical Supply (rpm - bhp)

CFM	AVAILABLE EXTERNAL STATIC PRESSURE (in. wg)									
	0.2		0.4		0.6		0.8		1.0	
	rpm	bhp	rpm	bhp	rpm	bhp	rpm	bhp	rpm	bhp
2550	1091	0.48	1198	0.63	1298	0.81	1391	0.99	1478	1.19
2765	1164	0.58	1264	0.74	1359	0.92	1448	1.11	1532	1.31
2975	1238	0.69	1332	0.85	1422	1.04	1507	1.24	1588	1.45
3190	1312	0.81	1402	0.98	1487	1.17	1569	1.38	1646	1.59
3400	1388	0.94	1473	1.12	1554	1.32	1632	1.53	1706	1.75
3615	1464	1.08	1544	1.27	1622	1.47	1696	1.69	1768	1.91
3825	1541	1.24	1617	1.43	1691	1.64	1762	1.85	1831	2.08
4040	1618	1.40	1691	1.59	1761	1.80	1830	2.02	1896	2.25
4250	1696	1.56	1765	1.76	1832	1.97	1898	2.19	1962	2.42

CFM	AVAILABLE EXTERNAL STATIC PRESSURE (in. wg)									
	1.2		1.4		1.6		1.8		2.0	
	rpm	bhp	rpm	bhp	rpm	bhp	rpm	bhp	rpm	bhp
2550	1559	1.40	1636	1.61	1709	1.84	1779	2.08	1846	2.32
2765	1611	1.53	1686	1.75	1758	1.98	1826	2.22	1892	2.47
2975	1665	1.67	1738	1.90	1808	2.14	1875	2.38	1939	2.63
3190	1721	1.82	1792	2.05	1860	2.30	1925	2.55	1988	2.80
3400	1778	1.98	1847	2.22	1913	2.46	1977	2.72	2039	2.98
3615	1837	2.14	1904	2.38	1969	2.64	2031	2.89	2091	3.16
3825	1898	2.31	1963	2.56	2026	2.81	2086	3.07	—	—
4040	1961	2.49	2023	2.73	2084	2.98	—	—	—	—
4250	2024	2.66	2085	2.90	2144	3.16	—	—	—	—

Std/Med Static 1091-2000 rpm, 2.4 maximum bhp

High Static 1091-2200 rpm, 3.0 maximum bhp

RGF102 — Standard/Medium Static — 8.5 Ton Vertical Supply (rpm - vdc)

CFM	AVAILABLE EXTERNAL STATIC PRESSURE (in. wg)									
	0.2		0.4		0.6		0.8		1.0	
	rpm	vdc	rpm	vdc	rpm	vdc	rpm	vdc	rpm	vdc
2550	1091	5.3	1198	5.9	1298	6.4	1391	6.9	1478	7.3
2765	1164	5.7	1264	6.2	1359	6.7	1448	7.2	1532	7.6
2975	1238	6.1	1332	6.6	1422	7.0	1507	7.5	1588	7.9
3190	1312	6.5	1402	6.9	1487	7.4	1569	7.8	1646	8.2
3400	1388	6.9	1473	7.3	1554	7.7	1632	8.1	1706	8.5
3615	1464	7.2	1544	7.7	1622	8.1	1696	8.4	1768	8.8
3825	1541	7.6	1617	8.0	1691	8.4	1762	8.8	1831	9.1
4040	1618	8.0	1691	8.4	1761	8.8	1830	9.1	1896	9.5
4250	1696	8.4	1765	8.8	1832	9.1	1898	9.5	1962	9.8

CFM	AVAILABLE EXTERNAL STATIC PRESSURE (in. wg)									
	1.2		1.4		1.6		1.8		2.0	
	rpm	vdc	rpm	vdc	rpm	vdc	rpm	vdc	rpm	vdc
2550	1559	7.7	1636	8.1	1709	8.5	1779	8.9	1846	9.2
2765	1611	8.0	1686	8.4	1758	8.8	1826	9.1	—	—
2975	1665	8.3	1738	8.7	1808	9.0	1875	9.4	—	—
3190	1721	8.6	1792	8.9	1860	9.3	—	—	—	—
3400	1778	8.9	1847	9.2	—	—	—	—	—	—
3615	1837	9.2	1904	9.5	—	—	—	—	—	—
3825	1898	9.5	—	—	—	—	—	—	—	—
4040	—	—	—	—	—	—	—	—	—	—
4250	—	—	—	—	—	—	—	—	—	—

Std/Med Static 1091-2000 rpm

Fan data (cont)

RGF102 — High Static — 8.5 Ton Vertical Supply (rpm - vdc)

CFM	AVAILABLE EXTERNAL STATIC PRESSURE (in. wg)									
	0.2		0.4		0.6		0.8		1.0	
	rpm	vdc	rpm	vdc	rpm	vdc	rpm	vdc	rpm	vdc
2550	1091	4.9	1198	5.4	1298	5.8	1391	6.3	1478	6.7
2765	1164	5.2	1264	5.7	1359	6.1	1448	6.5	1532	6.9
2975	1238	5.6	1332	6.0	1422	6.4	1507	6.8	1588	7.2
3190	1312	5.9	1402	6.3	1487	6.7	1569	7.1	1646	7.4
3400	1388	6.3	1473	6.6	1554	7.0	1632	7.4	1706	7.7
3615	1464	6.6	1544	7.0	1622	7.3	1696	7.7	1768	8.0
3825	1541	7.0	1617	7.3	1691	7.7	1762	8.0	1831	8.3
4040	1618	7.3	1691	7.7	1761	8.0	1830	8.3	1896	8.6
4250	1696	7.7	1765	8.0	1832	8.3	1898	8.6	1962	8.9

CFM	AVAILABLE EXTERNAL STATIC PRESSURE (in. wg)									
	1.2		1.4		1.6		1.8		2.0	
	rpm	vdc	rpm	vdc	rpm	vdc	rpm	vdc	rpm	vdc
2550	1559	7.0	1636	7.4	1709	7.7	1779	8.1	1846	8.4
2765	1611	7.3	1686	7.6	1758	8.0	1826	8.3	1892	8.6
2975	1665	7.5	1738	7.9	1808	8.2	1875	8.5	1939	8.8
3190	1721	7.8	1792	8.1	1860	8.4	1925	8.7	1988	9.0
3400	1778	8.1	1847	8.4	1913	8.7	1977	9.0	2039	9.3
3615	1837	8.3	1904	8.6	1969	8.9	2031	9.2	2091	9.5
3825	1898	8.6	1963	8.9	2026	9.2	2086	9.5	—	—
4040	1961	8.9	2023	9.2	2084	9.5	—	—	—	—
4250	2024	9.2	2085	9.5	2144	9.7	—	—	—	—

High Static 1091-2200 rpm

Fan data (cont)

RGF120 — 10 Ton Vertical Supply (rpm - bhp)

CFM	AVAILABLE EXTERNAL STATIC PRESSURE (in. wg)									
	0.2		0.4		0.6		0.8		1.0	
	rpm	bhp	rpm	bhp	rpm	bhp	rpm	bhp	rpm	bhp
3000	1266	0.74	1360	0.92	1449	1.12	1534	1.32	1613	1.54
3250	1357	0.91	1444	1.09	1528	1.29	1608	1.51	1684	1.73
3500	1448	1.09	1530	1.28	1609	1.49	1685	1.72	1758	1.95
3750	1539	1.29	1617	1.49	1691	1.71	1764	1.94	1833	2.18
4000	1632	1.51	1705	1.72	1775	1.94	1844	2.18	1911	2.42
4250	1725	1.74	1794	1.96	1861	2.19	1926	2.43	1990	2.68
4500	1818	1.99	1884	2.22	1948	2.45	2010	2.69	2071	2.94
4750	1912	2.25	1974	2.47	2035	2.71	2095	2.96	2153	3.21
5000	2006	2.51	2066	2.74	2124	2.98	2181	3.23	—	—

CFM	AVAILABLE EXTERNAL STATIC PRESSURE (in. wg)									
	1.2		1.4		1.6		1.8		2.0	
	rpm	bhp	rpm	bhp	rpm	bhp	rpm	bhp	rpm	bhp
3000	1689	1.77	1762	2.01	1831	2.25	1897	2.50	1961	2.77
3250	1757	1.97	1827	2.21	1894	2.47	1959	2.73	2021	3.00
3500	1828	2.19	1895	2.44	1960	2.70	2023	2.97	2084	3.25
3750	1900	2.42	1965	2.68	2028	2.95	2089	3.22	2148	3.50
4000	1975	2.67	2038	2.94	2099	3.21	2158	3.49	—	—
4250	2052	2.94	2112	3.20	2171	3.48	—	—	—	—
4500	2130	3.20	2188	3.47	—	—	—	—	—	—
4750	—	—	—	—	—	—	—	—	—	—
5000	—	—	—	—	—	—	—	—	—	—

Std/Med Static 1266-2000 rpm, 2.4 maximum bhp

High Static 1266-2200 rpm, 5.0 maximum bhp

RGF120 — Standard/Medium Static — 10 Ton Vertical Supply (rpm - vdc)

CFM	AVAILABLE EXTERNAL STATIC PRESSURE (in. wg)									
	0.2		0.4		0.6		0.8		1.0	
	rpm	vdc	rpm	vdc	rpm	vdc	rpm	vdc	rpm	vdc
3000	1266	6.2	1360	6.7	1449	7.2	1534	7.6	1613	8.0
3250	1357	6.7	1444	7.1	1528	7.6	1608	8.0	1684	8.4
3500	1448	7.2	1530	7.6	1609	8.0	1685	8.4	1758	8.8
3750	1539	7.6	1617	8.0	1691	8.4	1764	8.8	1833	9.1
4000	1632	8.1	1705	8.5	1775	8.8	1844	9.2	—	—
4250	1725	8.6	1794	8.9	1861	9.3	—	—	—	—
4500	1818	9.1	1884	9.4	—	—	—	—	—	—
4750	1912	9.5	—	—	—	—	—	—	—	—
5000	—	—	—	—	—	—	—	—	—	—

CFM	AVAILABLE EXTERNAL STATIC PRESSURE (in. wg)									
	1.2		1.4		1.6		1.8		2.0	
	rpm	vdc	rpm	vdc	rpm	vdc	rpm	vdc	rpm	vdc
3000	1689	8.4	1762	8.8	1831	9.1	—	—	—	—
3250	1757	8.8	1827	9.1	—	—	—	—	—	—
3500	1828	9.1	—	—	—	—	—	—	—	—
3750	—	—	—	—	—	—	—	—	—	—
4000	—	—	—	—	—	—	—	—	—	—
4250	—	—	—	—	—	—	—	—	—	—
4500	—	—	—	—	—	—	—	—	—	—
4750	—	—	—	—	—	—	—	—	—	—
5000	—	—	—	—	—	—	—	—	—	—

Std/Med Static 1266-2000 rpm

Fan data (cont)

RGF120 — High Static — 10 Ton Vertical Supply (rpm - vdc)

CFM	AVAILABLE EXTERNAL STATIC PRESSURE (in. wg)									
	0.2		0.4		0.6		0.8		1.0	
	rpm	vdc	rpm	vdc	rpm	vdc	rpm	vdc	rpm	vdc
3000	1266	5.7	1360	6.1	1449	6.5	1534	6.9	1613	7.3
3250	1357	6.1	1444	6.5	1528	6.9	1608	7.3	1684	7.6
3500	1448	6.5	1530	6.9	1609	7.3	1685	7.6	1758	8.0
3750	1539	6.9	1617	7.3	1691	7.7	1764	8.0	1833	8.3
4000	1632	7.4	1705	7.7	1775	8.0	1844	8.4	1911	8.7
4250	1725	7.8	1794	8.1	1861	8.4	1926	8.7	1990	9.0
4500	1818	8.2	1884	8.5	1948	8.8	2010	9.1	2071	9.4
4750	1912	8.7	1974	9.0	2035	9.2	2095	9.5	2153	9.8
5000	2006	9.1	2066	9.4	2124	9.6	2181	9.9	—	—

CFM	AVAILABLE EXTERNAL STATIC PRESSURE (in. wg)									
	1.2		1.4		1.6		1.8		2.0	
	rpm	vdc	rpm	vdc	rpm	vdc	rpm	vdc	rpm	vdc
3000	1689	7.6	1762	8.0	1831	8.3	1897	8.6	1961	8.9
3250	1757	8.0	1827	8.3	1894	8.6	1959	8.9	2021	9.2
3500	1828	8.3	1895	8.6	1960	8.9	2023	9.2	2084	9.5
3750	1900	8.6	1965	8.9	2028	9.2	2089	9.5	2148	9.8
4000	1975	9.0	2038	9.3	2099	9.5	2158	9.8	—	—
4250	2052	9.3	2112	9.6	2171	9.9	—	—	—	—
4500	2130	9.7	2188	9.9	—	—	—	—	—	—
4750	—	—	—	—	—	—	—	—	—	—
5000	—	—	—	—	—	—	—	—	—	—

High Static 1266-2200 rpm

Fan data (cont)

RGF150 — 12.5 Ton Vertical Supply (rpm - bhp)

CFM	AVAILABLE EXTERNAL STATIC PRESSURE (in. wg)									
	0.2		0.4		0.6		0.8		1.0	
	rpm	bhp	rpm	bhp	rpm	bhp	rpm	bhp	rpm	bhp
3750	1320	1.21	1416	1.49	1503	1.79	1583	2.09	1657	2.39
4065	1414	1.48	1504	1.78	1587	2.09	1664	2.41	1736	2.74
4375	1509	1.79	1594	2.11	1673	2.44	1747	2.78	1817	3.13
4690	1604	2.14	1685	2.49	1761	2.84	1832	3.19	1899	3.56
5000	1700	2.54	1777	2.90	1849	3.26	1918	3.64	1983	4.03
5315	1797	2.97	1870	3.35	1939	3.73	2005	4.13	2068	4.53
5625	1894	3.44	1964	3.84	2030	4.24	2093	4.65	2154	5.06
5940	1992	3.95	2058	4.36	2121	4.77	—	—	—	—
6250	2090	4.50	2153	4.92	—	—	—	—	—	—

CFM	AVAILABLE EXTERNAL STATIC PRESSURE (in. wg)									
	1.2		1.4		1.6		1.8		2.0	
	rpm	bhp	rpm	bhp	rpm	bhp	rpm	bhp	rpm	bhp
3750	1727	2.71	1794	3.04	1857	3.37	1918	3.71	1976	4.06
4065	1804	3.08	1869	3.42	1930	3.77	1989	4.12	2046	4.49
4375	1883	3.48	1946	3.85	2005	4.21	2063	4.58	2119	4.97
4690	1963	3.93	2024	4.31	2082	4.69	2139	5.08	—	—
5000	2045	4.42	2104	4.81	—	—	—	—	—	—
5315	2128	4.93	—	—	—	—	—	—	—	—
5625	—	—	—	—	—	—	—	—	—	—
5940	—	—	—	—	—	—	—	—	—	—
6250	—	—	—	—	—	—	—	—	—	—

Std/Med Static 1320-2200 rpm, 3.0 maximum bhp

High Static 1320-2200 rpm, 5.0 maximum bhp

RGF150 — Standard/Medium Static — 12.5 Ton Vertical Supply (rpm - vdc)

CFM	AVAILABLE EXTERNAL STATIC PRESSURE (in. wg)									
	0.2		0.4		0.6		0.8		1.0	
	rpm	vdc	rpm	vdc	rpm	vdc	rpm	vdc	rpm	vdc
3750	1320	5.9	1416	6.4	1503	6.8	1583	7.2	1657	7.5
4065	1414	6.4	1504	6.8	1587	7.2	1664	7.5	1736	7.9
4375	1509	6.8	1594	7.2	1673	7.6	1747	7.9	—	—
4690	1604	7.2	1685	7.6	1761	8.0	—	—	—	—
5000	1700	7.7	1777	8.0	—	—	—	—	—	—
5315	1797	8.1	—	—	—	—	—	—	—	—
5625	—	—	—	—	—	—	—	—	—	—
5940	—	—	—	—	—	—	—	—	—	—
6250	—	—	—	—	—	—	—	—	—	—

CFM	AVAILABLE EXTERNAL STATIC PRESSURE (in. wg)									
	1.2		1.4		1.6		1.8		2.0	
	rpm	vdc	rpm	vdc	rpm	vdc	rpm	vdc	rpm	vdc
3750	1727	7.8	—	—	—	—	—	—	—	—
4065	—	—	—	—	—	—	—	—	—	—
4375	—	—	—	—	—	—	—	—	—	—
4690	—	—	—	—	—	—	—	—	—	—
5000	—	—	—	—	—	—	—	—	—	—
5315	—	—	—	—	—	—	—	—	—	—
5625	—	—	—	—	—	—	—	—	—	—
5940	—	—	—	—	—	—	—	—	—	—
6250	—	—	—	—	—	—	—	—	—	—

Std/Med Static 1320-2200 rpm

Fan data (cont)

RGF150 — High Static — 12.5 Ton Vertical Supply (rpm - vdc)

CFM	AVAILABLE EXTERNAL STATIC PRESSURE (in. wg)									
	0.2		0.4		0.6		0.8		1.0	
	rpm	vdc	rpm	vdc	rpm	vdc	rpm	vdc	rpm	vdc
3750	1320	5.9	1416	6.4	1503	6.8	1583	7.2	1657	7.5
4065	1414	6.4	1504	6.8	1587	7.2	1664	7.5	1736	7.9
4375	1509	6.8	1594	7.2	1673	7.6	1747	7.9	1817	8.2
4690	1604	7.2	1685	7.6	1761	8.0	1832	8.3	1899	8.6
5000	1700	7.7	1777	8.0	1849	8.4	1918	8.7	1983	9.0
5315	1797	8.1	1870	8.5	1939	8.8	2005	9.1	2068	9.4
5625	1894	8.6	1964	8.9	2030	9.2	2093	9.5	2154	9.8
5940	1992	9.0	2058	9.3	2121	9.6	—	—	—	—
6250	2090	9.5	2153	9.8	—	—	—	—	—	—

CFM	AVAILABLE EXTERNAL STATIC PRESSURE (in. wg)									
	1.2		1.4		1.6		1.8		2.0	
	rpm	vdc	rpm	vdc	rpm	vdc	rpm	vdc	rpm	vdc
3750	1727	7.8	1794	8.1	1857	8.4	1918	8.7	1976	9.0
4065	1804	8.2	1869	8.5	1930	8.8	1989	9.0	2046	9.3
4375	1883	8.5	1946	8.8	2005	9.1	2063	9.4	2119	9.6
4690	1963	8.9	2024	9.2	2082	9.5	2139	9.7	—	—
5000	2045	9.3	2104	9.6	—	—	—	—	—	—
5315	2128	9.7	—	—	—	—	—	—	—	—
5625	—	—	—	—	—	—	—	—	—	—
5940	—	—	—	—	—	—	—	—	—	—
6250	—	—	—	—	—	—	—	—	—	—

High Static 1320-2200 rpm

Fan data (cont)

RGF180 — 15 Ton Vertical Supply (rpm - bhp)

CFM	AVAILABLE EXTERNAL STATIC PRESSURE (in. wg)									
	0.2		0.4		0.6		0.8		1.0	
	rpm	bhp	rpm	bhp	rpm	bhp	rpm	bhp	rpm	bhp
4500	1251	1.02	1332	1.23	1412	1.47	1491	1.73	1569	2.02
4875	1343	1.26	1417	1.48	1491	1.72	1565	1.99	1637	2.28
5250	1435	1.52	1504	1.75	1573	2.00	1641	2.28	1709	2.57
5625	1528	1.81	1592	2.05	1657	2.31	1721	2.59	1785	2.89
6000	1621	2.13	1682	2.38	1742	2.64	1802	2.92	1862	3.23
6375	1715	2.47	1772	2.73	1829	3.00	1886	3.29	1942	3.59
6750	1810	2.86	1863	3.11	1917	3.39	1971	3.69	2024	3.99
7125	1905	3.29	1955	3.56	2006	3.84	2057	4.15	2108	4.46
7500	2000	3.82	2048	4.10	2096	4.40	2144	4.71	2193	5.04

CFM	AVAILABLE EXTERNAL STATIC PRESSURE (in. wg)									
	1.2		1.4		1.6		1.8		2.0	
	rpm	bhp	rpm	bhp	rpm	bhp	rpm	bhp	rpm	bhp
4500	1645	2.33	1719	2.65	1792	3.01	1862	3.37	1930	3.76
4875	1709	2.59	1779	2.93	1848	3.28	1915	3.65	1981	4.04
5250	1777	2.89	1843	3.22	1908	3.58	1973	3.95	2036	4.35
5625	1848	3.21	1911	3.55	1973	3.90	2034	4.28	2094	4.67
6000	1922	3.55	1981	3.88	2040	4.24	2098	4.61	2156	5.01
6375	1999	3.92	2055	4.26	2111	4.61	2166	4.98	—	—
6750	2078	4.32	2131	4.66	2184	5.02	—	—	—	—
7125	2158	4.79	—	—	—	—	—	—	—	—
7500	—	—	—	—	—	—	—	—	—	—

Std/Med Static 1251-2200 rpm, 3.0 maximum bhp

High Static 1251-2200 rpm, 5.0 maximum bhp

RGF180 — Standard/Medium Static — 15 Ton Vertical Supply (rpm - vdc)

CFM	AVAILABLE EXTERNAL STATIC PRESSURE (in. wg)									
	0.2		0.4		0.6		0.8		1.0	
	rpm	vdc	rpm	vdc	rpm	vdc	rpm	vdc	rpm	vdc
4500	1251	5.6	1332	6.0	1412	6.4	1491	6.7	1569	7.1
4875	1343	6.0	1417	6.4	1491	6.7	1565	7.1	1637	7.4
5250	1435	6.5	1504	6.8	1573	7.1	1641	7.4	1709	7.7
5625	1528	6.9	1592	7.2	1657	7.5	1721	7.8	1785	8.1
6000	1621	7.3	1682	7.6	1742	7.9	1802	8.2	—	—
6375	1715	7.8	1772	8.0	—	—	—	—	—	—
6750	1810	8.2	—	—	—	—	—	—	—	—
7125	—	—	—	—	—	—	—	—	—	—
7500	—	—	—	—	—	—	—	—	—	—

CFM	AVAILABLE EXTERNAL STATIC PRESSURE (in. wg)									
	1.2		1.4		1.6		1.8		2.0	
	rpm	vdc	rpm	vdc	rpm	vdc	rpm	vdc	rpm	vdc
4500	1645	7.4	1719	7.8	—	—	—	—	—	—
4875	1709	7.7	1779	8.1	—	—	—	—	—	—
5250	1777	8.0	—	—	—	—	—	—	—	—
5625	—	—	—	—	—	—	—	—	—	—
6000	—	—	—	—	—	—	—	—	—	—
6375	—	—	—	—	—	—	—	—	—	—
6750	—	—	—	—	—	—	—	—	—	—
7125	—	—	—	—	—	—	—	—	—	—
7500	—	—	—	—	—	—	—	—	—	—

Std/Med Static 1251-2200 rpm

Fan data (cont)

RGF180 — High Static — 15 Ton Vertical Supply (rpm - vdc)

CFM	AVAILABLE EXTERNAL STATIC PRESSURE (in. wg)									
	0.2		0.4		0.6		0.8		1.0	
	rpm	vdc	rpm	vdc	rpm	vdc	rpm	vdc	rpm	vdc
4500	1251	5.6	1332	6.0	1412	6.4	1491	6.7	1569	7.1
4875	1343	6.0	1417	6.4	1491	6.7	1565	7.1	1637	7.4
5250	1435	6.5	1504	6.8	1573	7.1	1641	7.4	1709	7.7
5625	1528	6.9	1592	7.2	1657	7.5	1721	7.8	1785	8.1
6000	1621	7.3	1682	7.6	1742	7.9	1802	8.2	1862	8.4
6375	1715	7.8	1772	8.0	1829	8.3	1886	8.6	1942	8.8
6750	1810	8.2	1863	8.4	1917	8.7	1971	8.9	2024	9.2
7125	1905	8.6	1955	8.9	2006	9.1	2057	9.3	2108	9.6
7500	2000	9.1	2048	9.3	2096	9.5	2144	9.7	2193	10.0

CFM	AVAILABLE EXTERNAL STATIC PRESSURE (in. wg)									
	1.2		1.4		1.6		1.8		2.0	
	rpm	vdc	rpm	vdc	rpm	vdc	rpm	vdc	rpm	vdc
4500	1645	7.4	1719	7.8	1792	8.1	1862	8.4	1930	8.8
4875	1709	7.7	1779	8.1	1848	8.4	1915	8.7	1981	9.0
5250	1777	8.0	1843	8.4	1908	8.7	1973	9.0	2036	9.2
5625	1848	8.4	1911	8.7	1973	9.0	2034	9.2	2094	9.5
6000	1922	8.7	1981	9.0	2040	9.3	2098	9.5	2156	9.8
6375	1999	9.1	2055	9.3	2111	9.6	2166	9.8	—	—
6750	2078	9.4	2131	9.7	2184	9.9	—	—	—	—
7125	2158	9.8	—	—	—	—	—	—	—	—
7500	—	—	—	—	—	—	—	—	—	—

High Static 1251-2200 rpm

Fan data (cont)

RGF090 — 7.5 Ton Horizontal Supply (rpm - bhp)

CFM	AVAILABLE EXTERNAL STATIC PRESSURE (in. wg)									
	0.2		0.4		0.6		0.8		1.0	
	rpm	bhp	rpm	bhp	rpm	bhp	rpm	bhp	rpm	bhp
2250	987	0.36	1114	0.52	1227	0.70	1331	0.89	1428	1.10
2440	1047	0.43	1168	0.60	1277	0.78	1377	0.98	1471	1.20
2625	1109	0.51	1223	0.68	1328	0.87	1424	1.08	1515	1.30
2815	1171	0.60	1280	0.78	1380	0.97	1474	1.19	1561	1.41
3000	1234	0.69	1338	0.88	1434	1.08	1524	1.30	1609	1.53
3190	1298	0.79	1397	0.99	1490	1.20	1577	1.42	1659	1.65
3375	1363	0.90	1458	1.10	1546	1.32	1630	1.54	1710	1.78
3565	1428	1.02	1519	1.22	1604	1.44	1685	1.67	1762	1.91
3750	1494	1.14	1580	1.35	1663	1.57	1741	1.80	1816	2.05

CFM	AVAILABLE EXTERNAL STATIC PRESSURE (in. wg)									
	1.2		1.4		1.6		1.8		2.0	
	rpm	bhp	rpm	bhp	rpm	bhp	rpm	bhp	rpm	bhp
2250	1518	1.32	1602	1.55	1682	1.79	1757	2.04	1830	2.31
2440	1558	1.42	1641	1.66	1719	1.91	1794	2.17	1865	2.44
2625	1600	1.53	1681	1.77	1758	2.03	1831	2.29	1902	2.57
2815	1644	1.65	1723	1.90	1798	2.15	1871	2.43	1940	2.71
3000	1690	1.77	1767	2.02	1841	2.29	1911	2.56	1979	2.84
3190	1737	1.90	1813	2.16	1884	2.42	1954	2.70	2020	2.98
3375	1786	2.03	1859	2.29	1930	2.56	1997	2.84	2063	3.13
3565	1836	2.16	1908	2.43	1976	2.70	2042	2.98	—	—
3750	1888	2.30	1957	2.56	2024	2.83	2089	3.11	—	—

Std/Med Static 987-2000 rpm, 2.4 maximum bhp

High Static 987-2200 rpm, 3.0 maximum bhp

RGF090 — Standard/Medium Static — 7.5 Ton Horizontal Supply (rpm - vdc)

CFM	AVAILABLE EXTERNAL STATIC PRESSURE (in. wg)									
	0.2		0.4		0.6		0.8		1.0	
	rpm	vdc	rpm	vdc	rpm	vdc	rpm	vdc	rpm	vdc
2250	987	4.8	1114	5.4	1227	6.0	1331	6.6	1428	7.1
2440	1047	5.1	1168	5.7	1277	6.3	1377	6.8	1471	7.3
2625	1109	5.4	1223	6.0	1328	6.5	1424	7.0	1515	7.5
2815	1171	5.7	1280	6.3	1380	6.8	1474	7.3	1561	7.7
3000	1234	6.1	1338	6.6	1434	7.1	1524	7.6	1609	8.0
3190	1298	6.4	1397	6.9	1490	7.4	1577	7.8	1659	8.2
3375	1363	6.7	1458	7.2	1546	7.7	1630	8.1	1710	8.5
3565	1428	7.1	1519	7.5	1604	8.0	1685	8.4	1762	8.8
3750	1494	7.4	1580	7.8	1663	8.3	1741	8.7	1816	9.1

CFM	AVAILABLE EXTERNAL STATIC PRESSURE (in. wg)									
	1.2		1.4		1.6		1.8		2.0	
	rpm	vdc	rpm	vdc	rpm	vdc	rpm	vdc	rpm	vdc
2250	1518	7.5	1602	8.0	1682	8.4	1757	8.8	1830	9.1
2440	1558	7.7	1641	8.2	1719	8.6	1794	8.9	—	—
2625	1600	7.9	1681	8.4	1758	8.8	1831	9.1	—	—
2815	1644	8.2	1723	8.6	1798	9.0	—	—	—	—
3000	1690	8.4	1767	8.8	1841	9.2	—	—	—	—
3190	1737	8.6	1813	9.0	—	—	—	—	—	—
3375	1786	8.9	1859	9.3	—	—	—	—	—	—
3565	1836	9.2	—	—	—	—	—	—	—	—
3750	1888	9.4	—	—	—	—	—	—	—	—

Std/Med Static 987-2000 rpm

Fan data (cont)

RGF090 — High Static — 7.5 Ton Horizontal Supply (rpm - vdc)

CFM	AVAILABLE EXTERNAL STATIC PRESSURE (in. wg)									
	0.2		0.4		0.6		0.8		1.0	
	rpm	vdc	rpm	vdc	rpm	vdc	rpm	vdc	rpm	vdc
2250	987	4.4	1114	5.0	1227	5.5	1331	6.0	1428	6.4
2440	1047	4.7	1168	5.2	1277	5.7	1377	6.2	1471	6.6
2625	1109	5.0	1223	5.5	1328	6.0	1424	6.4	1515	6.8
2815	1171	5.3	1280	5.8	1380	6.2	1474	6.6	1561	7.1
3000	1234	5.5	1338	6.0	1434	6.5	1524	6.9	1609	7.3
3190	1298	5.8	1397	6.3	1490	6.7	1577	7.1	1659	7.5
3375	1363	6.1	1458	6.6	1546	7.0	1630	7.4	1710	7.7
3565	1428	6.4	1519	6.9	1604	7.2	1685	7.6	1762	8.0
3750	1494	6.7	1580	7.1	1663	7.5	1741	7.9	1816	8.2

CFM	AVAILABLE EXTERNAL STATIC PRESSURE (in. wg)									
	1.2		1.4		1.6		1.8		2.0	
	rpm	vdc	rpm	vdc	rpm	vdc	rpm	vdc	rpm	vdc
2250	1518	6.9	1602	7.2	1682	7.6	1757	8.0	1830	8.3
2440	1558	7.0	1641	7.4	1719	7.8	1794	8.1	1865	8.5
2625	1600	7.2	1681	7.6	1758	8.0	1831	8.3	1902	8.6
2815	1644	7.4	1723	7.8	1798	8.1	1871	8.5	1940	8.8
3000	1690	7.6	1767	8.0	1841	8.3	1911	8.7	1979	9.0
3190	1737	7.9	1813	8.2	1884	8.5	1954	8.9	2020	9.2
3375	1786	8.1	1859	8.4	1930	8.8	1997	9.1	2063	9.4
3565	1836	8.3	1908	8.7	1976	9.0	2042	9.3	—	—
3750	1888	8.6	1957	8.9	2024	9.2	2089	9.5	—	—

High Static 987-2200 rpm

Fan data (cont)

RGF102 — 8.5 Ton Horizontal Supply (rpm - bhp)

CFM	AVAILABLE EXTERNAL STATIC PRESSURE (in. wg)									
	0.2		0.4		0.6		0.8		1.0	
	rpm	bhp	rpm	bhp	rpm	bhp	rpm	bhp	rpm	bhp
2550	1026	0.40	1140	0.55	1248	0.72	1349	0.91	1442	1.11
2765	1092	0.48	1199	0.63	1301	0.80	1398	1.00	1488	1.20
2975	1160	0.56	1261	0.72	1357	0.90	1449	1.10	1536	1.31
3190	1229	0.66	1323	0.83	1414	1.01	1502	1.21	1586	1.42
3400	1298	0.77	1387	0.94	1473	1.12	1557	1.33	1638	1.55
3615	1368	0.88	1452	1.06	1535	1.25	1614	1.45	1692	1.67
3825	1439	1.01	1519	1.19	1597	1.38	1673	1.58	1747	1.80
4040	1511	1.14	1586	1.32	1660	1.51	1733	1.72	1804	1.94
4250	1582	1.27	1654	1.45	1725	1.64	1795	1.85	1863	2.07

CFM	AVAILABLE EXTERNAL STATIC PRESSURE (in. wg)									
	1.2		1.4		1.6		1.8		2.0	
	rpm	bhp	rpm	bhp	rpm	bhp	rpm	bhp	rpm	bhp
2550	1529	1.32	1611	1.54	1688	1.77	1761	2.01	1830	2.26
2765	1573	1.42	1654	1.65	1730	1.89	1802	2.14	1870	2.39
2975	1619	1.53	1698	1.77	1773	2.01	1844	2.27	1911	2.52
3190	1667	1.65	1743	1.89	1817	2.14	1887	2.40	1954	2.66
3400	1716	1.78	1790	2.02	1862	2.27	1931	2.53	1997	2.80
3615	1767	1.91	1839	2.15	1909	2.40	1977	2.67	2041	2.94
3825	1820	2.04	1890	2.28	1958	2.54	2024	2.80	2087	3.07
4040	1874	2.17	1942	2.42	2008	2.67	2072	2.93	—	—
4250	1930	2.30	1996	2.55	2060	2.80	2122	3.06	—	—

Std/Med Static 1026-2000 rpm, 2.4 maximum bhp

High Static 1026-2200 rpm, 3.0 maximum bhp

RGF102 — Standard/Medium Static — 8.5 Ton Horizontal Supply (rpm - vdc)

CFM	AVAILABLE EXTERNAL STATIC PRESSURE (in. wg)									
	0.2		0.4		0.6		0.8		1.0	
	rpm	vdc	rpm	vdc	rpm	vdc	rpm	vdc	rpm	vdc
2550	1026	5.0	1140	5.6	1248	6.1	1349	6.7	1442	7.1
2765	1092	5.3	1199	5.9	1301	6.4	1398	6.9	1488	7.4
2975	1160	5.7	1261	6.2	1357	6.7	1449	7.2	1536	7.6
3190	1229	6.0	1323	6.5	1414	7.0	1502	7.4	1586	7.9
3400	1298	6.4	1387	6.8	1473	7.3	1557	7.7	1638	8.1
3615	1368	6.7	1452	7.2	1535	7.6	1614	8.0	1692	8.4
3825	1439	7.1	1519	7.5	1597	7.9	1673	8.3	1747	8.7
4040	1511	7.5	1586	7.9	1660	8.3	1733	8.6	1804	9.0
4250	1582	7.9	1654	8.2	1725	8.6	1795	8.9	1863	9.3

CFM	AVAILABLE EXTERNAL STATIC PRESSURE (in. wg)									
	1.2		1.4		1.6		1.8		2.0	
	rpm	vdc	rpm	vdc	rpm	vdc	rpm	vdc	rpm	vdc
2550	1529	7.6	1611	8.0	1688	8.4	1761	8.8	1830	9.1
2765	1573	7.8	1654	8.2	1730	8.6	1802	9.0	1870	9.3
2975	1619	8.0	1698	8.4	1773	8.8	1844	9.2	—	—
3190	1667	8.3	1743	8.7	1817	9.1	1887	9.4	—	—
3400	1716	8.5	1790	8.9	1862	9.3	—	—	—	—
3615	1767	8.8	1839	9.2	1909	9.5	—	—	—	—
3825	1820	9.1	1890	9.4	—	—	—	—	—	—
4040	1874	9.4	—	—	—	—	—	—	—	—
4250	1930	9.6	—	—	—	—	—	—	—	—

Std/Med Static 1026-2000 rpm

Fan data (cont)

RGF102 — High Static — 8.5 Ton Horizontal Supply (rpm - vdc)

CFM	AVAILABLE EXTERNAL STATIC PRESSURE (in. wg)									
	0.2		0.4		0.6		0.8		1.0	
	rpm	vdc	rpm	vdc	rpm	vdc	rpm	vdc	rpm	vdc
2550	1026	4.6	1140	5.1	1248	5.6	1349	6.1	1442	6.5
2765	1092	4.9	1199	5.4	1301	5.9	1398	6.3	1488	6.7
2975	1160	5.2	1261	5.7	1357	6.1	1449	6.5	1536	6.9
3190	1229	5.5	1323	6.0	1414	6.4	1502	6.8	1586	7.2
3400	1298	5.8	1387	6.2	1473	6.6	1557	7.0	1638	7.4
3615	1368	6.2	1452	6.5	1535	6.9	1614	7.3	1692	7.7
3825	1439	6.5	1519	6.9	1597	7.2	1673	7.6	1747	7.9
4040	1511	6.8	1586	7.2	1660	7.5	1733	7.8	1804	8.2
4250.0	1582	7.1	1654	7.5	1725	7.8	1795	8.1	1863	8.4

CFM	AVAILABLE EXTERNAL STATIC PRESSURE (in. wg)									
	1.2		1.4		1.6		1.8		2.0	
	rpm	vdc	rpm	vdc	rpm	vdc	rpm	vdc	rpm	vdc
2550	1529	6.9	1611	7.3	1688	7.6	1761	8.0	1830	8.3
2765	1573	7.1	1654	7.5	1730	7.8	1802	8.2	1870	8.5
2975	1619	7.3	1698	7.7	1773	8.0	1844	8.4	1911	8.7
3190	1667	7.5	1743	7.9	1817	8.2	1887	8.6	1954	8.9
3400	1716	7.8	1790	8.1	1862	8.4	1931	8.8	1997	9.1
3615	1767	8.0	1839	8.3	1909	8.7	1977	9.0	2041	9.3
3825	1820	8.2	1890	8.6	1958	8.9	2024	9.2	2087	9.5
4040	1874	8.5	1942	8.8	2008	9.1	2072	9.4	—	—
4250	1930	8.8	1996	9.1	2060	9.4	2122	9.6	—	—

High Static 1026-2200 rpm

Fan data (cont)

RGF120 — 10 Ton Horizontal Supply (rpm - bhp)

CFM	AVAILABLE EXTERNAL STATIC PRESSURE (in. wg)									
	0.2		0.4		0.6		0.8		1.0	
	rpm	bhp	rpm	bhp	rpm	bhp	rpm	bhp	rpm	bhp
3000	1188	0.62	1288	0.78	1384	0.97	1475	1.18	1562	1.40
3250	1271	0.75	1364	0.92	1454	1.12	1540	1.33	1623	1.55
3500	1355	0.89	1441	1.07	1526	1.27	1608	1.49	1687	1.72
3750	1439	1.05	1521	1.24	1600	1.45	1678	1.67	1753	1.90
4000	1525	1.23	1601	1.42	1676	1.63	1750	1.86	1822	2.10
4250	1611	1.42	1683	1.62	1754	1.83	1824	2.06	1892	2.30
4500	1697	1.62	1765	1.82	1833	2.04	1899	2.27	1965	2.51
4750	1784	1.83	1849	2.03	1913	2.25	1976	2.48	2038	2.72
5000	1872	2.04	1933	2.25	1994	2.47	2054	2.70	2114	2.94

CFM	AVAILABLE EXTERNAL STATIC PRESSURE (in. wg)									
	1.2		1.4		1.6		1.8		2.0	
	rpm	bhp	rpm	bhp	rpm	bhp	rpm	bhp	rpm	bhp
3000	1644	1.63	1722	1.87	1796	2.13	1866	2.38	1933	2.65
3250	1702	1.79	1778	2.04	1850	2.30	1919	2.57	1985	2.84
3500	1763	1.96	1836	2.22	1906	2.48	1974	2.76	2039	3.04
3750	1826	2.15	1897	2.41	1965	2.68	2031	2.96	2094	3.24
4000	1892	2.35	1960	2.61	2026	2.89	2090	3.17	2152	3.46
4250	1959	2.56	2025	2.82	2088	3.09	2150	3.38	—	—
4500	2029	2.77	2092	3.03	2153	3.31	—	—	—	—
4750	2100	2.98	2160	3.24	—	—	—	—	—	—
5000	2173	3.19	—	—	—	—	—	—	—	—

Std/Med Static 1188-2000 rpm, 2.4 maximum bhp

High Static 1188-2200 rpm, 5.0 maximum bhp

RGF120 — Standard/Medium Static — 10 Ton Horizontal Supply (rpm - vdc)

CFM	AVAILABLE EXTERNAL STATIC PRESSURE (in. wg)									
	0.2		0.4		0.6		0.8		1.0	
	rpm	vdc	rpm	vdc	rpm	vdc	rpm	vdc	rpm	vdc
3000	1188	5.8	1288	6.3	1384	6.8	1475	7.3	1562	7.7
3250	1271	6.3	1364	6.7	1454	7.2	1540	7.6	1623	8.1
3500	1355	6.7	1441	7.1	1526	7.6	1608	8.0	1687	8.4
3750	1439	7.1	1521	7.5	1600	7.9	1678	8.3	1753	8.7
4000	1525	7.6	1601	7.9	1676	8.3	1750	8.7	1822	9.1
4250	1611	8.0	1683	8.4	1754	8.7	1824	9.1	1892	9.4
4500	1697	8.4	1765	8.8	1833	9.1	1899	9.5	—	—
4750	1784	8.9	1849	9.2	1913	9.6	—	—	—	—
5000	1872	9.3	1933	9.7	—	—	—	—	—	—

CFM	AVAILABLE EXTERNAL STATIC PRESSURE (in. wg)									
	1.2		1.4		1.6		1.8		2.0	
	rpm	vdc	rpm	vdc	rpm	vdc	rpm	vdc	rpm	vdc
3000	1644	8.2	1722	8.6	1796	9.0	1866	9.3	—	—
3250	1702	8.5	1778	8.9	1850	9.2	—	—	—	—
3500	1763	8.8	1836	9.2	1906	9.5	—	—	—	—
3750	1826	9.1	1897	9.5	—	—	—	—	—	—
4000	1892	9.4	—	—	—	—	—	—	—	—
4250	—	—	—	—	—	—	—	—	—	—
4500	—	—	—	—	—	—	—	—	—	—
4750	—	—	—	—	—	—	—	—	—	—
5000	—	—	—	—	—	—	—	—	—	—

Std/Med Static 1188-2000 rpm

Fan data (cont)

RGF120 — High Static — 10 Ton Horizontal Supply (rpm - vdc)

CFM	AVAILABLE EXTERNAL STATIC PRESSURE (in. wg)									
	0.2		0.4		0.6		0.8		1.0	
	rpm	vdc	rpm	vdc	rpm	vdc	rpm	vdc	rpm	vdc
3000	1188	5.3	1288	5.8	1384	6.2	1475	6.7	1562	7.1
3250	1271	5.7	1364	6.1	1454	6.6	1540	7.0	1623	7.3
3500	1355	6.1	1441	6.5	1526	6.9	1608	7.3	1687	7.6
3750	1439	6.5	1521	6.9	1600	7.2	1678	7.6	1753	7.9
4000	1525	6.9	1601	7.2	1676	7.6	1750	7.9	1822	8.3
4250	1611	7.3	1683	7.6	1754	7.9	1824	8.3	1892	8.6
4500	1697	7.7	1765	8.0	1833	8.3	1899	8.6	1965	8.9
4750	1784	8.1	1849	8.4	1913	8.7	1976	9.0	2038	9.3
5000	1872	8.5	1933	8.8	1994	9.0	2054	9.3	2114	9.6

CFM	AVAILABLE EXTERNAL STATIC PRESSURE (in. wg)									
	1.2		1.4		1.6		1.8		2.0	
	rpm	vdc	rpm	vdc	rpm	vdc	rpm	vdc	rpm	vdc
3000	1644	7.4	1722	7.8	1796	8.1	1866	8.5	1933	8.8
3250	1702	7.7	1778	8.1	1850	8.4	1919	8.7	1985	9.0
3500	1763	8.0	1836	8.3	1906	8.6	1974	9.0	2039	9.3
3750	1826	8.3	1897	8.6	1965	8.9	2031	9.2	2094	9.5
4000	1892	8.6	1960	8.9	2026	9.2	2090	9.5	2152	9.8
4250	1959	8.9	2025	9.2	2088	9.5	2150	9.8	—	—
4500	2029	9.2	2092	9.5	2153	9.8	—	—	—	—
4750	2100	9.5	2160	9.8	—	—	—	—	—	—
5000	2173	9.9	—	—	—	—	—	—	—	—

High Static 1188-2200 rpm

Fan data (cont)

RGF150 — 12.5 Ton Horizontal Supply (rpm - bhp)

CFM	AVAILABLE EXTERNAL STATIC PRESSURE (in. wg)									
	0.2		0.4		0.6		0.8		1.0	
	rpm	bhp	rpm	bhp	rpm	bhp	rpm	bhp	rpm	bhp
3750	1198	0.90	1298	1.15	1393	1.42	1483	1.72	1566	2.02
4065	1282	1.10	1374	1.36	1464	1.64	1550	1.95	1631	2.27
4375	1367	1.33	1453	1.60	1537	1.90	1619	2.21	1697	2.55
4690	1453	1.59	1533	1.87	1613	2.18	1690	2.51	1765	2.86
5000	1540	1.89	1615	2.17	1690	2.49	1763	2.83	1835	3.19
5315	1628	2.21	1697	2.50	1768	2.83	1838	3.18	1906	3.55
5625	1715	2.56	1781	2.86	1847	3.19	1914	3.55	1979	3.93
5940	1804	2.94	1866	3.25	1929	3.59	1992	3.95	2054	4.33
6250	1892	3.34	1951	3.66	2011	4.01	2071	4.37	2131	4.77

CFM	AVAILABLE EXTERNAL STATIC PRESSURE (in. wg)									
	1.2		1.4		1.6		1.8		2.0	
	rpm	bhp	rpm	bhp	rpm	bhp	rpm	bhp	rpm	bhp
3750	1644	2.34	1718	2.67	1787	3.00	1854	3.35	1917	3.70
4065	1707	2.61	1778	2.95	1847	3.30	1912	3.66	1974	4.03
4375	1771	2.90	1841	3.26	1908	3.63	1971	4.00	2033	4.39
4690	1836	3.22	1905	3.59	1970	3.97	2033	4.37	2093	4.76
5000	1904	3.56	1970	3.95	2034	4.34	2095	4.75	2154	5.16
5315	1973	3.93	2037	4.33	2099	4.74	2159	5.15	—	—
5625	2043	4.32	2106	4.73	2166	5.15	—	—	—	—
5940	2116	4.74	2176	5.15	—	—	—	—	—	—
6250	2189	5.17	—	—	—	—	—	—	—	—

Std/Med Static 1198-2200 rpm, 3.0 maximum bhp

High Static 1198-2200 rpm, 5.0 maximum bhp

RGF150 — Standard/Medium Static — 12.5 Ton Horizontal Supply (rpm - vdc)

CFM	AVAILABLE EXTERNAL STATIC PRESSURE (in. wg)									
	0.2		0.4		0.6		0.8		1.0	
	rpm	vdc	rpm	vdc	rpm	vdc	rpm	vdc	rpm	vdc
3750	1198	5.4	1298	5.8	1393	6.3	1483	6.7	1566	7.1
4065	1282	5.8	1374	6.2	1464	6.6	1550	7.0	1631	7.4
4375	1367	6.2	1453	6.6	1537	6.9	1619	7.3	1697	7.7
4690	1453	6.6	1533	6.9	1613	7.3	1690	7.6	1765	8.0
5000	1540	7.0	1615	7.3	1690	7.6	1763	8.0	—	—
5315	1628	7.4	1697	7.7	1768	8.0	—	—	—	—
5625	1715	7.8	1781	8.1	—	—	—	—	—	—
5940	1804	8.2	—	—	—	—	—	—	—	—
6250	—	—	—	—	—	—	—	—	—	—

CFM	AVAILABLE EXTERNAL STATIC PRESSURE (in. wg)									
	1.2		1.4		1.6		1.8		2.0	
	rpm	vdc	rpm	vdc	rpm	vdc	rpm	vdc	rpm	vdc
3750	1644	7.4	1718	7.8	1787	8.1	—	—	—	—
4065	1707	7.7	1778	8.1	—	—	—	—	—	—
4375	1771	8.0	—	—	—	—	—	—	—	—
4690	—	—	—	—	—	—	—	—	—	—
5000	—	—	—	—	—	—	—	—	—	—
5315	—	—	—	—	—	—	—	—	—	—
5625	—	—	—	—	—	—	—	—	—	—
5940	—	—	—	—	—	—	—	—	—	—
6250	—	—	—	—	—	—	—	—	—	—

Std/Med Static 1198-2200 rpm

Fan data (cont)

RGF150 — High Static — 12.5 Ton Horizontal Supply (rpm - vdc)

CFM	AVAILABLE EXTERNAL STATIC PRESSURE (in. wg)									
	0.2		0.4		0.6		0.8		1.0	
	rpm	vdc	rpm	vdc	rpm	vdc	rpm	vdc	rpm	vdc
3750	1198	5.4	1298	5.8	1393	6.3	1483	6.7	1566	7.1
4065	1282	5.8	1374	6.2	1464	6.6	1550	7.0	1631	7.4
4375	1367	6.2	1453	6.6	1537	6.9	1619	7.3	1697	7.7
4690	1453	6.6	1533	6.9	1613	7.3	1690	7.6	1765	8.0
5000	1540	7.0	1615	7.3	1690	7.6	1763	8.0	1835	8.3
5315	1628	7.4	1697	7.7	1768	8.0	1838	8.3	1906	8.6
5625	1715	7.8	1781	8.1	1847	8.4	1914	8.7	1979	9.0
5940	1804	8.2	1866	8.5	1929	8.7	1992	9.0	2054	9.3
6250	1892	8.6	1951	8.9	2011	9.1	2071	9.4	2131	9.7

CFM	AVAILABLE EXTERNAL STATIC PRESSURE (in. wg)									
	1.2		1.4		1.6		1.8		2.0	
	rpm	vdc	rpm	vdc	rpm	vdc	rpm	vdc	rpm	vdc
3750	1644	7.4	1718	7.8	1787	8.1	1854	8.4	1917	8.7
4065	1707	7.7	1778	8.1	1847	8.4	1912	8.7	1974	9.0
4375	1771	8.0	1841	8.3	1908	8.7	1971	8.9	2033	9.2
4690	1836	8.3	1905	8.6	1970	8.9	2033	9.2	2093	9.5
5000	1904	8.6	1970	8.9	2034	9.2	2095	9.5	2154	9.8
5315	1973	9.0	2037	9.2	2099	9.5	2159	9.8	—	—
5625	2043	9.3	2106	9.6	2166	9.8	—	—	—	—
5940	2116	9.6	2176	9.9	—	—	—	—	—	—
6250	2189	9.9	—	—	—	—	—	—	—	—

High Static 1198-2200 rpm

Fan data (cont)

RGF180 — 15 Ton Horizontal Supply (rpm - bhp)

CFM	AVAILABLE EXTERNAL STATIC PRESSURE (in. wg)									
	0.2		0.4		0.6		0.8		1.0	
	rpm	bhp	rpm	bhp	rpm	bhp	rpm	bhp	rpm	bhp
4500	1248	1.02	1328	1.22	1408	1.46	1487	1.72	1566	2.01
4875	1339	1.25	1413	1.47	1487	1.71	1561	1.98	1634	2.27
5250	1431	1.51	1500	1.74	1568	1.98	1637	2.26	1705	2.55
5625	1524	1.80	1588	2.03	1652	2.29	1716	2.57	1780	2.87
6000	1617	2.11	1677	2.36	1737	2.62	1797	2.90	1857	3.20
6375	1711	2.46	1767	2.71	1824	2.98	1881	3.26	1937	3.56
6750	1805	2.83	1858	3.09	1912	3.37	1965	3.65	2019	3.96
7125	1899	3.26	1950	3.53	2001	3.82	2051	4.11	2102	4.42
7500	1994	3.79	2042	4.07	2090	4.36	2139	4.68	2187	5.00

CFM	AVAILABLE EXTERNAL STATIC PRESSURE (in. wg)									
	1.2		1.4		1.6		1.8		2.0	
	rpm	bhp	rpm	bhp	rpm	bhp	rpm	bhp	rpm	bhp
4500	1642	2.31	1717	2.64	1790	3.00	1861	3.37	1929	3.75
4875	1705	2.58	1776	2.91	1845	3.26	1913	3.64	1979	4.03
5250	1773	2.87	1839	3.20	1905	3.56	1970	3.94	2033	4.33
5625	1843	3.18	1906	3.52	1968	3.87	2030	4.25	2090	4.64
6000	1917	3.52	1976	3.86	2035	4.21	2094	4.59	2151	4.97
6375	1993	3.88	2050	4.22	2105	4.57	2161	4.95	—	—
6750	2072	4.28	2125	4.62	2178	4.98	—	—	—	—
7125	2153	4.75	—	—	—	—	—	—	—	—
7500	—	—	—	—	—	—	—	—	—	—

Std/Med Static 1248-2200 rpm, 3.0 maximum bhp

High Static 1248-2200 rpm, 5.0 maximum bhp

RGF180 — Standard/Medium Static — 15 Ton Horizontal Supply (rpm - vdc)

CFM	AVAILABLE EXTERNAL STATIC PRESSURE (in. wg)									
	0.2		0.4		0.6		0.8		1.0	
	rpm	vdc	rpm	vdc	rpm	vdc	rpm	vdc	rpm	vdc
4500	1248	5.6	1328	6.0	1408	6.3	1487	6.7	1566	7.1
4875	1339	6.0	1413	6.4	1487	6.7	1561	7.1	1634	7.4
5250	1431	6.5	1500	6.8	1568	7.1	1637	7.4	1705	7.7
5625	1524	6.9	1588	7.2	1652	7.5	1716	7.8	1780	8.1
6000	1617	7.3	1677	7.6	1737	7.9	1797	8.1	—	—
6375	1711	7.7	1767	8.0	1824	8.3	—	—	—	—
6750	1805	8.2	—	—	—	—	—	—	—	—
7125	—	—	—	—	—	—	—	—	—	—
7500	—	—	—	—	—	—	—	—	—	—

CFM	AVAILABLE EXTERNAL STATIC PRESSURE (in. wg)									
	1.2		1.4		1.6		1.8		2.0	
	rpm	vdc	rpm	vdc	rpm	vdc	rpm	vdc	rpm	vdc
4500	1642	7.4	1717	7.8	—	—	—	—	—	—
4875	1705	7.7	1776	8.0	—	—	—	—	—	—
5250	1773	8.0	—	—	—	—	—	—	—	—
5625	—	—	—	—	—	—	—	—	—	—
6000	—	—	—	—	—	—	—	—	—	—
6375	—	—	—	—	—	—	—	—	—	—
6750	—	—	—	—	—	—	—	—	—	—
7125	—	—	—	—	—	—	—	—	—	—
7500	—	—	—	—	—	—	—	—	—	—

Std/Med Static 1248-2200 rpm

Fan data (cont)

RGF180 — High Static — 15 Ton Horizontal Supply (rpm - vdc)

CFM	AVAILABLE EXTERNAL STATIC PRESSURE (in. wg)									
	0.2		0.4		0.6		0.8		1.0	
	rpm	vdc	rpm	vdc	rpm	vdc	rpm	vdc	rpm	vdc
4500	1248	5.6	1328	6.0	1408	6.3	1487	6.7	1566	7.1
4875	1339	6.0	1413	6.4	1487	6.7	1561	7.1	1634	7.4
5250	1431	6.5	1500	6.8	1568	7.1	1637	7.4	1705	7.7
5625	1524	6.9	1588	7.2	1652	7.5	1716	7.8	1780	8.1
6000	1617	7.3	1677	7.6	1737	7.9	1797	8.1	1857	8.4
6375	1711	7.7	1767	8.0	1824	8.3	1881	8.5	1937	8.8
6750	1805	8.2	1858	8.4	1912	8.7	1965	8.9	2019	9.2
7125	1899	8.6	1950	8.8	2001	9.1	2051	9.3	2102	9.5
7500	1994	9.0	2042	9.3	2090	9.5	2139	9.7	2187	9.9

CFM	AVAILABLE EXTERNAL STATIC PRESSURE (in. wg)									
	1.2		1.4		1.6		1.8		2.0	
	rpm	vdc	rpm	vdc	rpm	vdc	rpm	vdc	rpm	vdc
4500	1642	7.4	1717	7.8	1790	8.1	1861	8.4	1929	8.7
4875	1705	7.7	1776	8.0	1845	8.4	1913	8.7	1979	9.0
5250	1773	8.0	1839	8.3	1905	8.6	1970	8.9	2033	9.2
5625	1843	8.4	1906	8.6	1968	8.9	2030	9.2	2090	9.5
6000	1917	8.7	1976	9.0	2035	9.2	2094	9.5	2151	9.8
6375	1993	9.0	2050	9.3	2105	9.6	2161	9.8	—	—
6750	2072	9.4	2125	9.7	2178	9.9	—	—	—	—
7125	2153	9.8	—	—	—	—	—	—	—	—
7500	—	—	—	—	—	—	—	—	—	—

High Static 1248-2200 rpm

Fan data (cont)

RAF090 — 7.5 Ton Vertical Supply (rpm - bhp)

CFM	AVAILABLE EXTERNAL STATIC PRESSURE (in. wg)									
	0.2		0.4		0.6		0.8		1.0	
	rpm	bhp	rpm	bhp	rpm	bhp	rpm	bhp	rpm	bhp
2250	970	0.34	1102	0.50	1216	0.68	1319	0.86	1414	1.07
2440	1031	0.41	1157	0.58	1267	0.76	1367	0.96	1459	1.17
2625	1092	0.49	1213	0.67	1320	0.86	1416	1.06	1506	1.28
2815	1155	0.57	1271	0.76	1374	0.96	1467	1.17	1554	1.39
3000	1219	0.66	1330	0.86	1429	1.07	1520	1.29	1605	1.52
3190	1284	0.77	1390	0.97	1486	1.19	1574	1.41	1656	1.64
3375	1349	0.87	1451	1.09	1544	1.31	1629	1.54	1709	1.78
3565	1415	0.99	1513	1.21	1603	1.44	1686	1.68	1764	1.92
3750	1481	1.11	1576	1.34	1662	1.57	1743	1.81	1819	2.06

CFM	AVAILABLE EXTERNAL STATIC PRESSURE (in. wg)									
	1.2		1.4		1.6		1.8		2.0	
	rpm	bhp	rpm	bhp	rpm	bhp	rpm	bhp	rpm	bhp
2250	1502	1.28	1585	1.50	1664	1.74	1739	1.98	1810	2.23
2440	1545	1.38	1626	1.61	1703	1.85	1777	2.11	1847	2.37
2625	1589	1.50	1669	1.74	1745	1.98	1817	2.24	1886	2.51
2815	1636	1.62	1713	1.86	1788	2.12	1858	2.38	1926	2.65
3000	1684	1.75	1760	2.00	1832	2.26	1901	2.52	1968	2.80
3190	1734	1.89	1808	2.14	1878	2.40	1946	2.67	2012	2.95
3375	1785	2.03	1857	2.28	1926	2.55	1992	2.82	2057	3.10
3565	1837	2.17	1908	2.43	1975	2.69	2040	2.97	—	—
3750	1891	2.31	1960	2.57	2026	2.84	2089	3.11	—	—

Std/Med Static 970-2000 rpm, 2.4 maximum bhp

High Static 970-2200 rpm, 3.0 maximum bhp

RAF090 — Standard/Medium Static — 7.5 Ton Vertical Supply (rpm - vdc)

CFM	AVAILABLE EXTERNAL STATIC PRESSURE (in. wg)									
	0.2		0.4		0.6		0.8		1.0	
	rpm	vdc	rpm	vdc	rpm	vdc	rpm	vdc	rpm	vdc
2250	970	4.7	1102	5.4	1216	6.0	1319	6.5	1414	7.0
2440	1031	5.0	1157	5.7	1267	6.2	1367	6.7	1459	7.2
2625	1092	5.3	1213	6.0	1320	6.5	1416	7.0	1506	7.5
2815	1155	5.7	1271	6.3	1374	6.8	1467	7.3	1554	7.7
3000	1219	6.0	1330	6.6	1429	7.1	1520	7.5	1605	8.0
3190	1284	6.3	1390	6.9	1486	7.4	1574	7.8	1656	8.2
3375	1349	6.7	1451	7.2	1544	7.7	1629	8.1	1709	8.5
3565	1415	7.0	1513	7.5	1603	8.0	1686	8.4	1764	8.8
3750	1481	7.3	1576	7.8	1662	8.3	1743	8.7	1819	9.1

CFM	AVAILABLE EXTERNAL STATIC PRESSURE (in. wg)									
	1.2		1.4		1.6		1.8		2.0	
	rpm	vdc	rpm	vdc	rpm	vdc	rpm	vdc	rpm	vdc
2250	1502	7.4	1585	7.9	1664	8.3	1739	8.7	1810	9.0
2440	1545	7.7	1626	8.1	1703	8.5	1777	8.9	1847	9.2
2625	1589	7.9	1669	8.3	1745	8.7	1817	9.1	—	—
2815	1636	8.1	1713	8.5	1788	8.9	1858	9.3	—	—
3000	1684	8.4	1760	8.8	1832	9.1	—	—	—	—
3190	1734	8.6	1808	9.0	1878	9.4	—	—	—	—
3375	1785	8.9	1857	9.3	—	—	—	—	—	—
3565	1837	9.2	—	—	—	—	—	—	—	—
3750	1891	9.4	—	—	—	—	—	—	—	—

Std/Med Static 970-2000 rpm

Fan data (cont)

RAF090 — High Static — 7.5 Ton Vertical Supply (rpm - vdc)

CFM	AVAILABLE EXTERNAL STATIC PRESSURE (in. wg)									
	0.2		0.4		0.6		0.8		1.0	
	rpm	vdc	rpm	vdc	rpm	vdc	rpm	vdc	rpm	vdc
2250	970	4.3	1102	4.9	1216	5.5	1319	5.9	1414	6.4
2440	1031	4.6	1157	5.2	1267	5.7	1367	6.2	1459	6.6
2625	1092	4.9	1213	5.4	1320	5.9	1416	6.4	1506	6.8
2815	1155	5.2	1271	5.7	1374	6.2	1467	6.6	1554	7.0
3000	1219	5.5	1330	6.0	1429	6.4	1520	6.9	1605	7.3
3190	1284	5.8	1390	6.3	1486	6.7	1574	7.1	1656	7.5
3375	1349	6.1	1451	6.5	1544	7.0	1629	7.4	1709	7.7
3565	1415	6.4	1513	6.8	1603	7.2	1686	7.6	1764	8.0
3750	1481	6.7	1576	7.1	1662	7.5	1743	7.9	1819	8.2

CFM	AVAILABLE EXTERNAL STATIC PRESSURE (in. wg)									
	1.2		1.4		1.6		1.8		2.0	
	rpm	vdc	rpm	vdc	rpm	vdc	rpm	vdc	rpm	vdc
2250	1502	6.8	1585	7.2	1664	7.5	1739	7.9	1810	8.2
2440	1545	7.0	1626	7.4	1703	7.7	1777	8.0	1847	8.4
2625	1589	7.2	1669	7.5	1745	7.9	1817	8.2	1886	8.6
2815	1636	7.4	1713	7.8	1788	8.1	1858	8.4	1926	8.7
3000	1684	7.6	1760	8.0	1832	8.3	1901	8.6	1968	8.9
3190	1734	7.8	1808	8.2	1878	8.5	1946	8.8	2012	9.1
3375	1785	8.1	1857	8.4	1926	8.7	1992	9.0	2057	9.3
3565	1837	8.3	1908	8.7	1975	9.0	2040	9.3	—	—
3750	1891	8.6	1960	8.9	2026	9.2	2089	9.5	—	—

High Static 970-2200 rpm

Fan data (cont)

RAF102 — 8.5 Ton Vertical Supply (rpm - bhp)

CFM	AVAILABLE EXTERNAL STATIC PRESSURE (in. wg)									
	0.2		0.4		0.6		0.8		1.0	
	rpm	bhp	rpm	bhp	rpm	bhp	rpm	bhp	rpm	bhp
2550	1015	0.39	1128	0.53	1233	0.69	1330	0.87	1421	1.06
2765	1084	0.47	1190	0.62	1289	0.78	1382	0.96	1470	1.16
2975	1154	0.56	1253	0.71	1348	0.89	1437	1.07	1521	1.27
3190	1225	0.66	1319	0.82	1408	1.00	1493	1.19	1574	1.39
3400	1297	0.77	1386	0.94	1470	1.12	1551	1.31	1629	1.52
3615	1370	0.89	1453	1.06	1534	1.25	1612	1.45	1687	1.66
3825	1443	1.02	1522	1.19	1599	1.38	1673	1.58	1745	1.80
4040	1517	1.15	1592	1.33	1665	1.52	1736	1.73	1806	1.94
4250	1591	1.29	1663	1.47	1733	1.67	1801	1.87	1867	2.09

CFM	AVAILABLE EXTERNAL STATIC PRESSURE (in. wg)									
	1.2		1.4		1.6		1.8		2.0	
	rpm	bhp	rpm	bhp	rpm	bhp	rpm	bhp	rpm	bhp
2550	1506	1.26	1586	1.47	1662	1.69	1734	1.92	1802	2.16
2765	1552	1.37	1630	1.58	1705	1.81	1776	2.05	1843	2.29
2975	1601	1.48	1677	1.70	1750	1.94	1819	2.17	1886	2.42
3190	1652	1.61	1726	1.84	1796	2.07	1864	2.31	1930	2.57
3400	1704	1.74	1776	1.97	1845	2.21	1911	2.45	1975	2.71
3615	1759	1.88	1828	2.11	1895	2.35	1960	2.60	2023	2.86
3825	1815	2.02	1882	2.25	1947	2.50	2011	2.75	2072	3.01
4040	1873	2.17	1938	2.40	2001	2.64	2063	2.90	2122	3.15
4250	1932	2.31	1995	2.54	2056	2.78	2116	3.04	—	—

Std/Med Static 1015-2000 rpm, 2.4 maximum bhp

High Static 1015-2200 rpm, 3.0 maximum bhp

RAF102 — Standard/Medium Static — 8.5 Ton Vertical Supply (rpm - vdc)

CFM	AVAILABLE EXTERNAL STATIC PRESSURE (in. wg)									
	0.2		0.4		0.6		0.8		1.0	
	rpm	vdc	rpm	vdc	rpm	vdc	rpm	vdc	rpm	vdc
2550	1015	4.9	1128	5.5	1233	6.1	1330	6.6	1421	7.0
2765	1084	5.3	1190	5.8	1289	6.3	1382	6.8	1470	7.3
2975	1154	5.6	1253	6.2	1348	6.6	1437	7.1	1521	7.5
3190	1225	6.0	1319	6.5	1408	7.0	1493	7.4	1574	7.8
3400	1297	6.4	1386	6.8	1470	7.3	1551	7.7	1629	8.1
3615	1370	6.8	1453	7.2	1534	7.6	1612	8.0	1687	8.4
3825	1443	7.1	1522	7.5	1599	7.9	1673	8.3	1745	8.7
4040	1517	7.5	1592	7.9	1665	8.3	1736	8.6	1806	9.0
4250	1591	7.9	1663	8.3	1733	8.6	1801	9.0	1867	9.3

CFM	AVAILABLE EXTERNAL STATIC PRESSURE (in. wg)									
	1.2		1.4		1.6		1.8		2.0	
	rpm	vdc	rpm	vdc	rpm	vdc	rpm	vdc	rpm	vdc
2550	1506	7.5	1586	7.9	1662	8.3	1734	8.6	1802	9.0
2765	1552	7.7	1630	8.1	1705	8.5	1776	8.8	1843	9.2
2975	1601	7.9	1677	8.3	1750	8.7	1819	9.1	—	—
3190	1652	8.2	1726	8.6	1796	9.0	—	—	—	—
3400	1704	8.5	1776	8.8	1845	9.2	—	—	—	—
3615	1759	8.8	1828	9.1	1895	9.5	—	—	—	—
3825	1815	9.0	1882	9.4	—	—	—	—	—	—
4040	1873	9.3	—	—	—	—	—	—	—	—
4250	1932	9.7	—	—	—	—	—	—	—	—

Std/Med Static 1015-2000 rpm

Fan data (cont)

RAF102 — High Static — 8.5 Ton Vertical Supply (rpm - vdc)

CFM	AVAILABLE EXTERNAL STATIC PRESSURE (in. wg)									
	0.2		0.4		0.6		0.8		1.0	
	rpm	vdc	rpm	vdc	rpm	vdc	rpm	vdc	rpm	vdc
2550	1015	4.5	1128	5.1	1233	5.5	1330	6.0	1421	6.4
2765	1084	4.8	1190	5.3	1289	5.8	1382	6.2	1470	6.6
2975	1154	5.2	1253	5.6	1348	6.1	1437	6.5	1521	6.9
3190	1225	5.5	1319	5.9	1408	6.3	1493	6.7	1574	7.1
3400	1297	5.8	1386	6.2	1470	6.6	1551	7.0	1629	7.4
3615	1370	6.2	1453	6.6	1534	6.9	1612	7.3	1687	7.6
3825	1443	6.5	1522	6.9	1599	7.2	1673	7.6	1745	7.9
4040	1517	6.8	1592	7.2	1665	7.5	1736	7.9	1806	8.2
4250	1591	7.2	1663	7.5	1733	7.8	1801	8.2	1867	8.5

CFM	AVAILABLE EXTERNAL STATIC PRESSURE (in. wg)									
	1.2		1.4		1.6		1.8		2.0	
	rpm	vdc	rpm	vdc	rpm	vdc	rpm	vdc	rpm	vdc
2550	1506	6.8	1586	7.2	1662	7.5	1734	7.8	1802	8.2
2765	1552	7.0	1630	7.4	1705	7.7	1776	8.0	1843	8.4
2975	1601	7.2	1677	7.6	1750	7.9	1819	8.2	1886	8.6
3190	1652	7.5	1726	7.8	1796	8.1	1864	8.4	1930	8.8
3400	1704	7.7	1776	8.0	1845	8.4	1911	8.7	1975	9.0
3615	1759	8.0	1828	8.3	1895	8.6	1960	8.9	2023	9.2
3825	1815	8.2	1882	8.5	1947	8.8	2011	9.1	2072	9.4
4040	1873	8.5	1938	8.8	2001	9.1	2063	9.4	2122	9.6
4250	1932	8.8	1995	9.1	2056	9.3	2116	9.6	—	—

High Static 1015-2200 rpm

Fan data (cont)

RAF120 — 10 Ton Vertical Supply (rpm - bhp)

CFM	AVAILABLE EXTERNAL STATIC PRESSURE (in. wg)									
	0.2		0.4		0.6		0.8		1.0	
	rpm	bhp	rpm	bhp	rpm	bhp	rpm	bhp	rpm	bhp
3000	1181	0.60	1279	0.77	1372	0.95	1461	1.14	1544	1.35
3250	1264	0.73	1356	0.91	1443	1.09	1527	1.29	1607	1.51
3500	1348	0.88	1434	1.06	1517	1.25	1596	1.46	1673	1.68
3750	1433	1.04	1514	1.23	1592	1.43	1667	1.64	1740	1.86
4000	1518	1.21	1595	1.41	1669	1.61	1740	1.83	1810	2.06
4250	1605	1.41	1677	1.60	1747	1.81	1815	2.03	1882	2.27
4500	1691	1.60	1760	1.81	1826	2.02	1892	2.24	1955	2.48
4750	1778	1.81	1843	2.01	1907	2.23	1969	2.46	2030	2.69
5000	1866	2.02	1928	2.23	1988	2.44	2048	2.67	2106	2.91

CFM	AVAILABLE EXTERNAL STATIC PRESSURE (in. wg)									
	1.2		1.4		1.6		1.8		2.0	
	rpm	bhp	rpm	bhp	rpm	bhp	rpm	bhp	rpm	bhp
3000	1624	1.57	1699	1.80	1771	2.04	1840	2.29	1906	2.54
3250	1684	1.73	1757	1.97	1827	2.21	1894	2.47	1958	2.72
3500	1746	1.91	1817	2.15	1884	2.40	1950	2.66	2013	2.92
3750	1811	2.10	1879	2.34	1945	2.60	2008	2.86	2070	3.13
4000	1878	2.30	1943	2.55	2007	2.81	2069	3.08	2128	3.35
4250	1947	2.51	2010	2.76	2071	3.02	2131	3.29	2189	3.56
4500	2017	2.72	2078	2.97	2138	3.24	2195	3.50	—	—
4750	2090	2.94	2148	3.19	—	—	—	—	—	—
5000	2164	3.15	—	—	—	—	—	—	—	—

Std/Med Static 1181-2000 rpm, 2.4 maximum bhp

High Static 1181-2200 rpm, 5.0 maximum bhp

RAF120 — Standard/Medium Static — 10 Ton Vertical Supply (rpm - vdc)

CFM	AVAILABLE EXTERNAL STATIC PRESSURE (in. wg)									
	0.2		0.4		0.6		0.8		1.0	
	rpm	vdc	rpm	vdc	rpm	vdc	rpm	vdc	rpm	vdc
3000	1181	5.8	1279	6.3	1372	6.8	1461	7.2	1544	7.7
3250	1264	6.2	1356	6.7	1443	7.1	1527	7.6	1607	8.0
3500	1348	6.6	1434	7.1	1517	7.5	1596	7.9	1673	8.3
3750	1433	7.1	1514	7.5	1592	7.9	1667	8.3	1740	8.7
4000	1518	7.5	1595	7.9	1669	8.3	1740	8.7	1810	9.0
4250	1605	8.0	1677	8.3	1747	8.7	1815	9.0	1882	9.4
4500	1691	8.4	1760	8.8	1826	9.1	1892	9.4	—	—
4750	1778	8.9	1843	9.2	1907	9.5	—	—	—	—
5000	1866	9.3	1928	9.6	1988	9.9	—	—	—	—

CFM	AVAILABLE EXTERNAL STATIC PRESSURE (in. wg)									
	1.2		1.4		1.6		1.8		2.0	
	rpm	vdc	rpm	vdc	rpm	vdc	rpm	vdc	rpm	vdc
3000	1624	8.1	1699	8.5	1771	8.8	1840	9.2	—	—
3250	1684	8.4	1757	8.8	1827	9.1	—	—	—	—
3500	1746	8.7	1817	9.1	1884	9.4	—	—	—	—
3750	1811	9.0	1879	9.4	—	—	—	—	—	—
4000	1878	9.4	—	—	—	—	—	—	—	—
4250	—	—	—	—	—	—	—	—	—	—
4500	—	—	—	—	—	—	—	—	—	—
4750	—	—	—	—	—	—	—	—	—	—
5000	—	—	—	—	—	—	—	—	—	—

Std/Med Static 1181-2000 rpm

Fan data (cont)

RAF120 — High Static — 10 Ton Vertical Supply (rpm - vdc)

CFM	AVAILABLE EXTERNAL STATIC PRESSURE (in. wg)									
	0.2		0.4		0.6		0.8		1.0	
	rpm	vdc	rpm	vdc	rpm	vdc	rpm	vdc	rpm	vdc
3000	1181	5.3	1279	5.7	1372	6.2	1461	6.6	1544	7.0
3250	1264	5.7	1356	6.1	1443	6.5	1527	6.9	1607	7.3
3500	1348	6.1	1434	6.5	1517	6.8	1596	7.2	1673	7.6
3750	1433	6.5	1514	6.8	1592	7.2	1667	7.5	1740	7.9
4000	1518	6.9	1595	7.2	1669	7.5	1740	7.9	1810	8.2
4250	1605	7.3	1677	7.6	1747	7.9	1815	8.2	1882	8.5
4500	1691	7.7	1760	8.0	1826	8.3	1892	8.6	1955	8.9
4750	1778	8.1	1843	8.4	1907	8.6	1969	8.9	2030	9.2
5000	1866	8.5	1928	8.7	1988	9.0	2048	9.3	2106	9.6

CFM	AVAILABLE EXTERNAL STATIC PRESSURE (in. wg)									
	1.2		1.4		1.6		1.8		2.0	
	rpm	vdc	rpm	vdc	rpm	vdc	rpm	vdc	rpm	vdc
3000	1624	7.3	1699	7.7	1771	8.0	1840	8.3	1906	8.6
3250	1684	7.6	1757	8.0	1827	8.3	1894	8.6	1958	8.9
3500	1746	7.9	1817	8.2	1884	8.5	1950	8.8	2013	9.1
3750	1811	8.2	1879	8.5	1945	8.8	2008	9.1	2070	9.4
4000	1878	8.5	1943	8.8	2007	9.1	2069	9.4	2128	9.7
4250	1947	8.8	2010	9.1	2071	9.4	2131	9.7	2189	9.9
4500	2017	9.2	2078	9.4	2138	9.7	2195	10.0	—	—
4750	2090	9.5	2148	9.8	—	—	—	—	—	—
5000	2164	9.8	—	—	—	—	—	—	—	—

High Static 1181-2200 rpm

Fan data (cont)

RAF150 — 12.5 Ton Vertical Supply (rpm - bhp)

CFM	AVAILABLE EXTERNAL STATIC PRESSURE (in. wg)									
	0.2		0.4		0.6		0.8		1.0	
	rpm	bhp	rpm	bhp	rpm	bhp	rpm	bhp	rpm	bhp
3750	1178	0.86	1287	1.12	1386	1.40	1475	1.69	1558	1.99
4065	1260	1.05	1362	1.32	1456	1.62	1543	1.92	1623	2.24
4375	1343	1.26	1438	1.55	1528	1.86	1612	2.19	1690	2.52
4690	1426	1.51	1516	1.81	1602	2.14	1683	2.48	1759	2.83
5000	1511	1.78	1595	2.09	1677	2.43	1755	2.79	1828	3.15
5315	1596	2.08	1675	2.41	1753	2.76	1828	3.13	1899	3.51
5625	1681	2.41	1756	2.74	1830	3.10	1902	3.49	1971	3.88
5940	1767	2.76	1838	3.10	1909	3.48	1978	3.87	2045	4.28
6250	1854	3.14	1921	3.49	1989	3.88	2055	4.27	2119	4.69

CFM	AVAILABLE EXTERNAL STATIC PRESSURE (in. wg)									
	1.2		1.4		1.6		1.8		2.0	
	rpm	bhp	rpm	bhp	rpm	bhp	rpm	bhp	rpm	bhp
3750	1634	2.29	1705	2.61	1772	2.93	1837	3.26	1898	3.60
4065	1698	2.57	1768	2.90	1834	3.23	1897	3.58	1957	3.93
4375	1763	2.86	1832	3.21	1897	3.56	1959	3.92	2018	4.29
4690	1830	3.18	1897	3.55	1961	3.92	2022	4.29	2081	4.68
5000	1898	3.53	1964	3.91	2027	4.30	2087	4.69	2144	5.09
5315	1967	3.90	2031	4.29	2093	4.69	2152	5.10	—	—
5625	2037	4.28	2100	4.69	2161	5.11	—	—	—	—
5940	2109	4.69	2170	5.11	—	—	—	—	—	—
6250	2181	5.11	—	—	—	—	—	—	—	—

Std/Med Static 1178-2200 rpm, 3.0 maximum bhp

High Static 1178-2200 rpm, 5.0 maximum bhp

RAF150 — Standard/Medium Static — 12.5 Ton Vertical Supply (rpm - vdc)

CFM	AVAILABLE EXTERNAL STATIC PRESSURE (in. wg)									
	0.2		0.4		0.6		0.8		1.0	
	rpm	vdc	rpm	vdc	rpm	vdc	rpm	vdc	rpm	vdc
3750	1178	5.3	1287	5.8	1386	6.2	1475	6.7	1558	7.0
4065	1260	5.7	1362	6.1	1456	6.6	1543	7.0	1623	7.3
4375	1343	6.0	1438	6.5	1528	6.9	1612	7.3	1690	7.6
4690	1426	6.4	1516	6.8	1602	7.2	1683	7.6	1759	8.0
5000	1511	6.8	1595	7.2	1677	7.6	1755	7.9	—	—
5315	1596	7.2	1675	7.6	1753	7.9	—	—	—	—
5625	1681	7.6	1756	8.0	—	—	—	—	—	—
5940	1767	8.0	—	—	—	—	—	—	—	—
6250	—	—	—	—	—	—	—	—	—	—

CFM	AVAILABLE EXTERNAL STATIC PRESSURE (in. wg)									
	1.2		1.4		1.6		1.8		2.0	
	rpm	vdc	rpm	vdc	rpm	vdc	rpm	vdc	rpm	vdc
3750	1634	7.4	1705	7.7	1772	8.0	—	—	—	—
4065	1698	7.7	1768	8.0	—	—	—	—	—	—
4375	1763	8.0	—	—	—	—	—	—	—	—
4690	—	—	—	—	—	—	—	—	—	—
5000	—	—	—	—	—	—	—	—	—	—
5315	—	—	—	—	—	—	—	—	—	—
5625	—	—	—	—	—	—	—	—	—	—
5940	—	—	—	—	—	—	—	—	—	—
6250	—	—	—	—	—	—	—	—	—	—

Std/Med Static 1178-2200 rpm

Fan data (cont)

RAF150 — High Static — 12.5 Ton Vertical Supply (rpm - vdc)

CFM	AVAILABLE EXTERNAL STATIC PRESSURE (in. wg)									
	0.2		0.4		0.6		0.8		1.0	
	rpm	vdc	rpm	vdc	rpm	vdc	rpm	vdc	rpm	vdc
3750	1178	5.3	1287	5.8	1386	6.2	1475	6.7	1558	7.0
4065	1260	5.7	1362	6.1	1456	6.6	1543	7.0	1623	7.3
4375	1343	6.0	1438	6.5	1528	6.9	1612	7.3	1690	7.6
4690	1426	6.4	1516	6.8	1602	7.2	1683	7.6	1759	8.0
5000	1511	6.8	1595	7.2	1677	7.6	1755	7.9	1828	8.3
5315	1596	7.2	1675	7.6	1753	7.9	1828	8.3	1899	8.6
5625	1681	7.6	1756	8.0	1830	8.3	1902	8.6	1971	8.9
5940	1767	8.0	1838	8.3	1909	8.7	1978	9.0	2045	9.3
6250	1854	8.4	1921	8.7	1989	9.0	2055	9.3	2119	9.6

CFM	AVAILABLE EXTERNAL STATIC PRESSURE (in. wg)									
	1.2		1.4		1.6		1.8		2.0	
	rpm	vdc	rpm	vdc	rpm	vdc	rpm	vdc	rpm	vdc
3750	1634	7.4	1705	7.7	1772	8.0	1837	8.3	1898	8.6
4065	1698	7.7	1768	8.0	1834	8.3	1897	8.6	1957	8.9
4375	1763	8.0	1832	8.3	1897	8.6	1959	8.9	2018	9.2
4690	1830	8.3	1897	8.6	1961	8.9	2022	9.2	2081	9.5
5000	1898	8.6	1964	8.9	2027	9.2	2087	9.5	2144	9.7
5315	1967	8.9	2031	9.2	2093	9.5	2152	9.8	—	—
5625	2037	9.2	2100	9.5	2161	9.8	—	—	—	—
5940	2109	9.6	2170	9.9	—	—	—	—	—	—
6250	2181	9.9	—	—	—	—	—	—	—	—

High Static 1178-2200 rpm

Fan data (cont)

RAF180 — 15 Ton Vertical Supply (rpm - bhp)

CFM	AVAILABLE EXTERNAL STATIC PRESSURE (in. wg)									
	0.2		0.4		0.6		0.8		1.0	
	rpm	bhp	rpm	bhp	rpm	bhp	rpm	bhp	rpm	bhp
4500	1120	0.73	1201	0.90	1281	1.10	1361	1.32	1441	1.56
4875	1208	0.92	1283	1.10	1357	1.30	1431	1.52	1505	1.77
5250	1297	1.12	1367	1.32	1436	1.52	1504	1.75	1573	2.00
5625	1387	1.36	1452	1.56	1516	1.77	1581	2.01	1645	2.26
6000	1477	1.61	1538	1.82	1598	2.04	1659	2.28	1719	2.54
6375	1568	1.89	1625	2.10	1682	2.33	1739	2.58	1796	2.84
6750	1659	2.20	1713	2.42	1767	2.66	1821	2.91	1874	3.17
7125	1751	2.56	1802	2.79	1891	3.23	1904	3.29	1955	3.56
7500	1842	2.99	1891	3.23	1891	3.23	1988	3.75	2036	4.03

CFM	AVAILABLE EXTERNAL STATIC PRESSURE (in. wg)									
	1.2		1.4		1.6		1.8		2.0	
	rpm	bhp	rpm	bhp	rpm	bhp	rpm	bhp	rpm	bhp
4500	1520	1.83	1597	2.13	1673	2.45	1747	2.79	1818	3.14
4875	1579	2.05	1651	2.34	1723	2.66	1793	2.99	1861	3.35
5250	1642	2.28	1710	2.57	1777	2.89	1844	3.23	1909	3.58
5625	1709	2.54	1773	2.83	1836	3.14	1899	3.48	1961	3.83
6000	1779	2.81	1840	3.11	1899	3.42	1959	3.76	2018	4.11
6375	1853	3.12	1909	3.41	1966	3.73	2022	4.05	2078	4.40
6750	1928	3.45	1982	3.75	2035	4.06	2089	4.39	2142	4.73
7125	2006	3.84	2056	4.14	2107	4.46	2158	4.79	—	—
7500	2085	4.33	2133	4.64	2181	4.96	—	—	—	—

Std/Med Static 1120-2200 rpm, 3.0 maximum bhp

High Static 1120-2200 rpm, 5.0 maximum bhp

RAF180 — Standard/Medium Static — 15 Ton Vertical Supply (rpm - vdc)

CFM	AVAILABLE EXTERNAL STATIC PRESSURE (in. wg)									
	0.2		0.4		0.6		0.8		1.0	
	rpm	vdc	rpm	vdc	rpm	vdc	rpm	vdc	rpm	vdc
4500	1120	5.0	1201	5.4	1281	5.8	1361	6.1	1441	6.5
4875	1208	5.4	1283	5.8	1357	6.1	1431	6.5	1505	6.8
5250	1297	5.8	1367	6.2	1436	6.5	1504	6.8	1573	7.1
5625	1387	6.2	1452	6.5	1516	6.8	1581	7.1	1645	7.4
6000	1477	6.7	1538	6.9	1598	7.2	1659	7.5	1719	7.8
6375	1568	7.1	1625	7.3	1682	7.6	1739	7.9	1796	8.1
6750	1659	7.5	1713	7.8	1767	8.0	1821	8.3	—	—
7125	1751	7.9	1802	8.2	—	—	—	—	—	—
7500	1842	8.3	—	—	—	—	—	—	—	—

CFM	AVAILABLE EXTERNAL STATIC PRESSURE (in. wg)									
	1.2		1.4		1.6		1.8		2.0	
	rpm	vdc	rpm	vdc	rpm	vdc	rpm	vdc	rpm	vdc
4500	1520	6.9	1597	7.2	1673	7.6	1747	7.9	—	—
4875	1579	7.1	1651	7.5	1723	7.8	1793	8.1	—	—
5250	1642	7.4	1710	7.7	1777	8.0	—	—	—	—
5625	1709	7.7	1773	8.0	1836	8.3	—	—	—	—
6000	1779	8.1	1840	8.3	—	—	—	—	—	—
6375	—	—	—	—	—	—	—	—	—	—
6750	—	—	—	—	—	—	—	—	—	—
7125	—	—	—	—	—	—	—	—	—	—
7500	—	—	—	—	—	—	—	—	—	—

Std/Med Static 1120-2200 rpm

Fan data (cont)

RAF180 — High Static — 15 Ton Vertical Supply (rpm - vdc)

CFM	AVAILABLE EXTERNAL STATIC PRESSURE (in. wg)									
	0.2		0.4		0.6		0.8		1.0	
	rpm	vdc	rpm	vdc	rpm	vdc	rpm	vdc	rpm	vdc
4500	1120	5.0	1201	5.4	1281	5.8	1361	6.1	1441	6.5
4875	1208	5.4	1283	5.8	1357	6.1	1431	6.5	1505	6.8
5250	1297	5.8	1367	6.2	1436	6.5	1504	6.8	1573	7.1
5625	1387	6.2	1452	6.5	1516	6.8	1581	7.1	1645	7.4
6000	1477	6.7	1538	6.9	1598	7.2	1659	7.5	1719	7.8
6375	1568	7.1	1625	7.3	1682	7.6	1739	7.9	1796	8.1
6750	1659	7.5	1713	7.8	1767	8.0	1821	8.3	1874	8.5
7125	1751	7.9	1802	8.2	1853	8.4	1904	8.6	1955	8.9
7500	1842	8.3	1891	8.6	1940	8.8	1988	9.0	2036	9.2

CFM	AVAILABLE EXTERNAL STATIC PRESSURE (in. wg)									
	1.2		1.4		1.6		1.8		2.0	
	rpm	vdc	rpm	vdc	rpm	vdc	rpm	vdc	rpm	vdc
4500	1520	6.9	1597	7.2	1673	7.6	1747	7.9	1818	8.2
4875	1579	7.1	1651	7.5	1723	7.8	1793	8.1	1861	8.4
5250	1642	7.4	1710	7.7	1777	8.0	1844	8.4	1909	8.7
5625	1709	7.7	1773	8.0	1836	8.3	1899	8.6	1961	8.9
6000	1779	8.1	1840	8.3	1899	8.6	1959	8.9	2018	9.2
6375	1853	8.4	1909	8.7	1966	8.9	2022	9.2	2078	9.4
6750	1928	8.7	1982	9.0	2035	9.2	2089	9.5	2142	9.7
7125	2006	9.1	2056	9.3	2107	9.6	2158	9.8	—	—
7500	2085	9.5	2133	9.7	2181	9.9	—	—	—	—

High Static 1120-2200 rpm

Fan data (cont)

RAF090 — 7.5 Ton Horizontal Supply (rpm - bhp)

CFM	AVAILABLE EXTERNAL STATIC PRESSURE (in. wg)									
	0.2		0.4		0.6		0.8		1.0	
	rpm	bhp	rpm	bhp	rpm	bhp	rpm	bhp	rpm	bhp
2250	910	0.28	1046	0.43	1167	0.60	1276	0.78	1376	0.98
2440	966	0.34	1095	0.49	1211	0.67	1316	0.86	1414	1.06
2625	1023	0.40	1145	0.56	1256	0.74	1359	0.94	1453	1.15
2815	1081	0.47	1197	0.64	1304	0.82	1403	1.02	1495	1.24
3000	1141	0.54	1251	0.72	1353	0.91	1449	1.12	1538	1.33
3190	1200	0.63	1306	0.81	1404	1.00	1496	1.21	1583	1.44
3375	1261	0.71	1361	0.90	1456	1.10	1545	1.31	1629	1.54
3565	1322	0.81	1418	1.00	1509	1.20	1595	1.42	1677	1.65
3750	1384	0.91	1476	1.10	1563	1.30	1646	1.52	1725	1.75

CFM	AVAILABLE EXTERNAL STATIC PRESSURE (in. wg)									
	1.2		1.4		1.6		1.8		2.0	
	rpm	bhp	rpm	bhp	rpm	bhp	rpm	bhp	rpm	bhp
2250	1469	1.19	1556	1.42	1639	1.66	1716	1.90	1790	2.16
2440	1505	1.28	1590	1.51	1671	1.75	1748	2.01	1821	2.27
2625	1542	1.37	1626	1.61	1705	1.85	1781	2.11	1853	2.38
2815	1581	1.46	1663	1.70	1741	1.96	1816	2.22	1887	2.49
3000	1622	1.57	1702	1.81	1778	2.06	1852	2.33	1922	2.60
3190	1665	1.67	1743	1.92	1818	2.18	1889	2.44	1958	2.72
3375	1709	1.78	1785	2.03	1858	2.29	1928	2.55	1996	2.83
3565	1755	1.89	1829	2.14	1900	2.40	1969	2.67	2035	2.95
3750	1801	2.00	1874	2.25	1944	2.51	2011	2.78	2076	3.06

Std/Med Static 910-2000 rpm, 2.4 maximum bhp

High Static 910-2200 rpm, 3.0 maximum bhp

RAF090 — Standard/Medium Static — 7.5 Ton Horizontal Supply (rpm - vdc)

CFM	AVAILABLE EXTERNAL STATIC PRESSURE (in. wg)									
	0.2		0.4		0.6		0.8		1.0	
	rpm	vdc	rpm	vdc	rpm	vdc	rpm	vdc	rpm	vdc
2250	910	4.4	1046	5.1	1167	5.7	1276	6.3	1376	6.8
2440	966	4.7	1095	5.3	1211	5.9	1316	6.5	1414	7.0
2625	1023	5.0	1145	5.6	1256	6.2	1359	6.7	1453	7.2
2815	1081	5.3	1197	5.9	1304	6.4	1403	6.9	1495	7.4
3000	1141	5.6	1251	6.1	1353	6.7	1449	7.2	1538	7.6
3190	1200	5.9	1306	6.4	1404	6.9	1496	7.4	1583	7.9
3375	1261	6.2	1361	6.7	1456	7.2	1545	7.7	1629	8.1
3565	1322	6.5	1418	7.0	1509	7.5	1595	7.9	1677	8.3
3750	1384	6.8	1476	7.3	1563	7.8	1646	8.2	1725	8.6

CFM	AVAILABLE EXTERNAL STATIC PRESSURE (in. wg)									
	1.2		1.4		1.6		1.8		2.0	
	rpm	vdc	rpm	vdc	rpm	vdc	rpm	vdc	rpm	vdc
2250	1469	7.3	1556	7.7	1639	8.1	1716	8.5	1790	8.9
2440	1505	7.5	1590	7.9	1671	8.3	1748	8.7	1821	9.1
2625	1542	7.6	1626	8.1	1705	8.5	1781	8.9	1853	9.2
2815	1581	7.8	1663	8.3	1741	8.7	1816	9.1	—	—
3000	1622	8.1	1702	8.5	1778	8.9	1852	9.2	—	—
3190	1665	8.3	1743	8.7	1818	9.1	—	—	—	—
3375	1709	8.5	1785	8.9	1858	9.3	—	—	—	—
3565	1755	8.7	1829	9.1	—	—	—	—	—	—
3750	1801	9.0	1874	9.4	—	—	—	—	—	—

Std/Med Static 910-2000 rpm

Fan data (cont)

RAF090 — High Static — 7.5 Ton Horizontal Supply (rpm - vdc)

CFM	AVAILABLE EXTERNAL STATIC PRESSURE (in. wg)									
	0.2		0.4		0.6		0.8		1.0	
	rpm	vdc	rpm	vdc	rpm	vdc	rpm	vdc	rpm	vdc
2250	910	4.0	1046	4.7	1167	5.2	1276	5.7	1376	6.2
2440	966	4.3	1095	4.9	1211	5.4	1316	5.9	1414	6.4
2625	1023	4.6	1145	5.1	1256	5.6	1359	6.1	1453	6.6
2815	1081	4.8	1197	5.4	1304	5.9	1403	6.3	1495	6.7
3000	1141	5.1	1251	5.6	1353	6.1	1449	6.5	1538	6.9
3190	1200	5.4	1306	5.9	1404	6.3	1496	6.8	1583	7.2
3375	1261	5.7	1361	6.1	1456	6.6	1545	7.0	1629	7.4
3565	1322	5.9	1418	6.4	1509	6.8	1595	7.2	1677	7.6
3750	1384	6.2	1476	6.7	1563	7.1	1646	7.4	1725	7.8

CFM	AVAILABLE EXTERNAL STATIC PRESSURE (in. wg)									
	1.2		1.4		1.6		1.8		2.0	
	rpm	vdc	rpm	vdc	rpm	vdc	rpm	vdc	rpm	vdc
2250	1469	6.6	1556	7.0	1639	7.4	1716	7.8	1790	8.1
2440	1505	6.8	1590	7.2	1671	7.6	1748	7.9	1821	8.3
2625	1542	7.0	1626	7.4	1705	7.7	1781	8.1	1853	8.4
2815	1581	7.1	1663	7.5	1741	7.9	1816	8.2	1887	8.6
3000	1622	7.3	1702	7.7	1778	8.1	1852	8.4	1922	8.7
3190	1665	7.5	1743	7.9	1818	8.2	1889	8.6	1958	8.9
3375	1709	7.7	1785	8.1	1858	8.4	1928	8.7	1996	9.1
3565	1755	7.9	1829	8.3	1900	8.6	1969	8.9	2035	9.2
3750	1801	8.2	1874	8.5	1944	8.8	2011	9.1	2076	9.4

High Static 910-2200 rpm

Fan data (cont)

RAF102 — 8.5 Ton Horizontal Supply (rpm - bhp)

CFM	AVAILABLE EXTERNAL STATIC PRESSURE (in. wg)									
	0.2		0.4		0.6		0.8		1.0	
	rpm	bhp	rpm	bhp	rpm	bhp	rpm	bhp	rpm	bhp
2550	947	0.31	1065	0.45	1178	0.60	1284	0.78	1382	0.97
2765	1010	0.38	1120	0.51	1226	0.67	1327	0.85	1422	1.05
2975	1074	0.45	1177	0.59	1277	0.75	1373	0.94	1464	1.13
3190	1139	0.53	1235	0.67	1329	0.84	1421	1.02	1508	1.22
3400	1205	0.62	1296	0.77	1384	0.93	1471	1.12	1555	1.32
3615	1272	0.71	1357	0.86	1441	1.03	1524	1.22	1604	1.43
3825	1340	0.81	1420	0.97	1499	1.14	1578	1.33	1655	1.53
4040	1407	0.92	1484	1.08	1559	1.25	1634	1.44	1707	1.64
4250	1476	1.03	1548	1.19	1620	1.36	1691	1.55	1762	1.75

CFM	AVAILABLE EXTERNAL STATIC PRESSURE (in. wg)									
	1.2		1.4		1.6		1.8		2.0	
	rpm	bhp	rpm	bhp	rpm	bhp	rpm	bhp	rpm	bhp
2550	1473	1.18	1558	1.39	1638	1.62	1713	1.85	1785	2.10
2765	1511	1.26	1595	1.48	1674	1.71	1748	1.95	1819	2.20
2975	1551	1.35	1633	1.57	1710	1.81	1784	2.05	1855	2.31
3190	1592	1.44	1672	1.67	1749	1.91	1822	2.16	1891	2.41
3400	1636	1.54	1714	1.77	1789	2.01	1860	2.26	1929	2.52
3615	1682	1.64	1757	1.87	1830	2.12	1900	2.37	1968	2.63
3825	1730	1.75	1803	1.98	1873	2.22	1942	2.48	2008	2.74
4040	1779	1.86	1850	2.09	1918	2.33	1985	2.58	2050	2.84
4250	1831	1.97	1899	2.19	1965	2.43	2030	2.68	2093	2.94

Std/Med Static 947-2000 rpm, 2.4 maximum bhp

High Static 947-2200 rpm, 3.0 maximum bhp

RAF102 — Standard/Medium Static — 8.5 Ton Horizontal Supply (rpm - vdc)

CFM	AVAILABLE EXTERNAL STATIC PRESSURE (in. wg)									
	0.2		0.4		0.6		0.8		1.0	
	rpm	vdc	rpm	vdc	rpm	vdc	rpm	vdc	rpm	vdc
2550	947	4.6	1065	5.2	1178	5.8	1284	6.3	1382	6.8
2765	1010	4.9	1120	5.5	1226	6.0	1327	6.5	1422	7.0
2975	1074	5.2	1177	5.8	1277	6.3	1373	6.8	1464	7.2
3190	1139	5.6	1235	6.1	1329	6.5	1421	7.0	1508	7.5
3400	1205	5.9	1296	6.4	1384	6.8	1471	7.3	1555	7.7
3615	1272	6.3	1357	6.7	1441	7.1	1524	7.6	1604	8.0
3825	1340	6.6	1420	7.0	1499	7.4	1578	7.8	1655	8.2
4040	1407	7.0	1484	7.3	1559	7.7	1634	8.1	1707	8.5
4250	1476	7.3	1548	7.7	1620	8.0	1691	8.4	1762	8.8

CFM	AVAILABLE EXTERNAL STATIC PRESSURE (in. wg)									
	1.2		1.4		1.6		1.8		2.0	
	rpm	vdc	rpm	vdc	rpm	vdc	rpm	vdc	rpm	vdc
2550	1473	7.3	1558	7.7	1638	8.1	1713	8.5	1785	8.9
2765	1511	7.5	1595	7.9	1674	8.3	1748	8.7	1819	9.1
2975	1551	7.7	1633	8.1	1710	8.5	1784	8.9	1855	9.3
3190	1592	7.9	1672	8.3	1749	8.7	1822	9.1	—	—
3400	1636	8.1	1714	8.5	1789	8.9	1860	9.3	—	—
3615	1682	8.4	1757	8.8	1830	9.1	1900	9.5	—	—
3825	1730	8.6	1803	9.0	1873	9.3	—	—	—	—
4040	1779	8.9	1850	9.2	1918	9.6	—	—	—	—
4250	1831	9.1	1899	9.5	—	—	—	—	—	—

Std/Med Static 947-2000 rpm

Fan data (cont)

RAF102 — High Static — 8.5 Ton Horizontal Supply (rpm - vdc)

CFM	AVAILABLE EXTERNAL STATIC PRESSURE (in. wg)									
	0.2		0.4		0.6		0.8		1.0	
	rpm	vdc	rpm	vdc	rpm	vdc	rpm	vdc	rpm	vdc
2550	947	4.2	1065	4.8	1178	5.3	1284	5.8	1382	6.2
2765	1010	4.5	1120	5.0	1226	5.5	1327	6.0	1422	6.4
2975	1074	4.8	1177	5.3	1277	5.7	1373	6.2	1464	6.6
3190	1139	5.1	1235	5.5	1329	6.0	1421	6.4	1508	6.8
3400	1205	5.4	1296	5.8	1384	6.2	1471	6.6	1555	7.0
3615	1272	5.7	1357	6.1	1441	6.5	1524	6.9	1604	7.2
3825	1340	6.0	1420	6.4	1499	6.8	1578	7.1	1655	7.5
4040	1407	6.3	1484	6.7	1559	7.0	1634	7.4	1707	7.7
4250	1476	6.7	1548	7.0	1620	7.3	1691	7.7	1762	8.0

CFM	AVAILABLE EXTERNAL STATIC PRESSURE (in. wg)									
	1.2		1.4		1.6		1.8		2.0	
	rpm	vdc	rpm	vdc	rpm	vdc	rpm	vdc	rpm	vdc
2550	1473	6.6	1558	7.0	1638	7.4	1713	7.8	1785	8.1
2765	1511	6.8	1595	7.2	1674	7.6	1748	7.9	1819	8.2
2975	1551	7.0	1633	7.4	1710	7.7	1784	8.1	1855	8.4
3190	1592	7.2	1672	7.6	1749	7.9	1822	8.3	1891	8.6
3400	1636	7.4	1714	7.8	1789	8.1	1860	8.4	1929	8.7
3615	1682	7.6	1757	8.0	1830	8.3	1900	8.6	1968	8.9
3825	1730	7.8	1803	8.2	1873	8.5	1942	8.8	2008	9.1
4040	1779	8.1	1850	8.4	1918	8.7	1985	9.0	2050	9.3
4250	1831	8.3	1899	8.6	1965	8.9	2030	9.2	2093	9.5

High Static 947-2200 rpm

Fan data (cont)

RAF120 — 10 Ton Horizontal Supply (rpm - bhp)

CFM	AVAILABLE EXTERNAL STATIC PRESSURE (in. wg)									
	0.2		0.4		0.6		0.8		1.0	
	rpm	bhp	rpm	bhp	rpm	bhp	rpm	bhp	rpm	bhp
3000	1100	0.49	1202	0.64	1301	0.81	1396	1.00	1487	1.21
3250	1176	0.59	1270	0.74	1363	0.92	1453	1.11	1539	1.32
3500	1252	0.70	1341	0.86	1428	1.04	1512	1.24	1595	1.45
3750	1330	0.83	1413	1.00	1495	1.18	1575	1.38	1653	1.60
4000	1409	0.97	1487	1.14	1563	1.33	1639	1.53	1714	1.75
4250	1488	1.12	1561	1.29	1634	1.48	1706	1.69	1776	1.90
4500	1568	1.28	1637	1.45	1706	1.65	1774	1.85	1841	2.07
4750	1648	1.44	1714	1.62	1779	1.81	1844	2.02	1908	2.23
5000	1728	1.61	1791	1.79	1853	1.98	1915	2.19	1976	2.40

CFM	AVAILABLE EXTERNAL STATIC PRESSURE (in. wg)									
	1.2		1.4		1.6		1.8		2.0	
	rpm	bhp	rpm	bhp	rpm	bhp	rpm	bhp	rpm	bhp
3000	1573	1.43	1654	1.66	1732	1.91	1805	2.16	1875	2.42
3250	1622	1.55	1702	1.79	1777	2.04	1849	2.29	1919	2.57
3500	1674	1.68	1751	1.92	1825	2.18	1895	2.44	1964	2.72
3750	1729	1.83	1803	2.07	1874	2.33	1943	2.59	2010	2.87
4000	1786	1.98	1857	2.22	1926	2.48	1993	2.75	2058	3.03
4250	1846	2.14	1914	2.38	1980	2.64	2045	2.91	2108	3.18
4500	1908	2.30	1973	2.54	2036	2.80	2099	3.06	2160	3.34
4750	1971	2.46	2034	2.71	2095	2.96	2155	3.22	—	—
5000	2036	2.63	2096	2.87	2155	3.11	—	—	—	—

Std/Med Static 1100-2000 rpm, 2.4 maximum bhp

High Static 1100-2200 rpm, 5.0 maximum bhp

RAF120 — Standard/Medium Static — 10 Ton Horizontal Supply (rpm - vdc)

CFM	AVAILABLE EXTERNAL STATIC PRESSURE (in. wg)									
	0.2		0.4		0.6		0.8		1.0	
	rpm	vdc	rpm	vdc	rpm	vdc	rpm	vdc	rpm	vdc
3000	1100	5.4	1202	5.9	1301	6.4	1396	6.9	1487	7.4
3250	1176	5.8	1270	6.2	1363	6.7	1453	7.2	1539	7.6
3500	1252	6.2	1341	6.6	1428	7.1	1512	7.5	1595	7.9
3750	1330	6.6	1413	7.0	1495	7.4	1575	7.8	1653	8.2
4000	1409	7.0	1487	7.4	1563	7.8	1639	8.1	1714	8.5
4250	1488	7.4	1561	7.7	1634	8.1	1706	8.5	1776	8.8
4500	1568	7.8	1637	8.1	1706	8.5	1774	8.8	1841	9.2
4750	1648	8.2	1714	8.5	1779	8.9	1844	9.2	1908	9.5
5000	1728	8.6	1791	8.9	1853	9.2	1915	9.6	1976	9.9

CFM	AVAILABLE EXTERNAL STATIC PRESSURE (in. wg)									
	1.2		1.4		1.6		1.8		2.0	
	rpm	vdc	rpm	vdc	rpm	vdc	rpm	vdc	rpm	vdc
3000	1573	7.8	1654	8.2	1732	8.6	1805	9.0	1875	9.4
3250	1622	8.1	1702	8.5	1777	8.9	1849	9.2	—	—
3500	1674	8.3	1751	8.7	1825	9.1	—	—	—	—
3750	1729	8.6	1803	9.0	1874	9.4	—	—	—	—
4000	1786	8.9	1857	9.3	—	—	—	—	—	—
4250	1846	9.2	1914	9.6	—	—	—	—	—	—
4500	1908	9.5	—	—	—	—	—	—	—	—
4750	—	—	—	—	—	—	—	—	—	—
5000	—	—	—	—	—	—	—	—	—	—

Std/Med Static 1100-2000 rpm

Fan data (cont)

RAF120 — High Static — 10 Ton Horizontal Supply (rpm - vdc)

CFM	AVAILABLE EXTERNAL STATIC PRESSURE (in. wg)									
	0.2		0.4		0.6		0.8		1.0	
	rpm	vdc	rpm	vdc	rpm	vdc	rpm	vdc	rpm	vdc
3000	1100	4.9	1202	5.4	1301	5.9	1396	6.3	1487	6.7
3250	1176	5.3	1270	5.7	1363	6.1	1453	6.6	1539	6.9
3500	1252	5.6	1341	6.0	1428	6.4	1512	6.8	1595	7.2
3750	1330	6.0	1413	6.4	1495	6.7	1575	7.1	1653	7.5
4000	1409	6.3	1487	6.7	1563	7.1	1639	7.4	1714	7.8
4250	1488	6.7	1561	7.1	1634	7.4	1706	7.7	1776	8.0
4500	1568	7.1	1637	7.4	1706	7.7	1774	8.0	1841	8.3
4750	1648	7.5	1714	7.8	1779	8.1	1844	8.4	1908	8.7
5000	1728	7.8	1791	8.1	1853	8.4	1915	8.7	1976	9.0

CFM	AVAILABLE EXTERNAL STATIC PRESSURE (in. wg)									
	1.2		1.4		1.6		1.8		2.0	
	rpm	vdc	rpm	vdc	rpm	vdc	rpm	vdc	rpm	vdc
3000	1573	7.1	1654	7.5	1732	7.8	1805	8.2	1875	8.5
3250	1622	7.3	1702	7.7	1777	8.0	1849	8.4	1919	8.7
3500	1674	7.6	1751	7.9	1825	8.3	1895	8.6	1964	8.9
3750	1729	7.8	1803	8.2	1874	8.5	1943	8.8	2010	9.1
4000	1786	8.1	1857	8.4	1926	8.7	1993	9.0	2058	9.3
4250	1846	8.4	1914	8.7	1980	9.0	2045	9.3	2108	9.6
4500	1908	8.7	1973	9.0	2036	9.2	2099	9.5	2160	9.8
4750	1971	8.9	2034	9.2	2095	9.5	2155	9.8	—	—
5000	2036	9.2	2096	9.5	2155	9.8	—	—	—	—

High Static 1100-2200 rpm

Fan data (cont)

RAF150 — 12.5 Ton Horizontal Supply (rpm - bhp)

CFM	AVAILABLE EXTERNAL STATIC PRESSURE (in. wg)									
	0.2		0.4		0.6		0.8		1.0	
	rpm	bhp	rpm	bhp	rpm	bhp	rpm	bhp	rpm	bhp
3750	1072	0.65	1166	0.83	1266	1.07	1363	1.33	1454	1.62
4065	1148	0.79	1233	0.98	1324	1.22	1416	1.49	1504	1.78
4375	1226	0.96	1303	1.15	1386	1.39	1472	1.66	1556	1.97
4690	1304	1.15	1374	1.35	1451	1.59	1530	1.86	1610	2.17
5000	1383	1.37	1448	1.57	1518	1.81	1592	2.08	1667	2.39
5315	1463	1.60	1523	1.81	1588	2.05	1656	2.33	1726	2.63
5625	1543	1.86	1599	2.07	1659	2.31	1723	2.59	1789	2.90
5940	1623	2.14	1675	2.35	1732	2.60	1791	2.87	1853	3.18
6250	1704	2.44	1753	2.65	1806	2.90	1861	3.17	1919	3.48

CFM	AVAILABLE EXTERNAL STATIC PRESSURE (in. wg)									
	1.2		1.4		1.6		1.8		2.0	
	rpm	bhp	rpm	bhp	rpm	bhp	rpm	bhp	rpm	bhp
3750	1540	1.92	1620	2.24	1694	2.56	1765	2.89	1833	3.24
4065	1587	2.09	1666	2.42	1740	2.76	1810	3.11	1877	3.46
4375	1637	2.29	1713	2.62	1786	2.97	1856	3.34	1922	3.71
4690	1688	2.50	1763	2.85	1834	3.20	1902	3.57	1968	3.96
5000	1741	2.72	1813	3.08	1883	3.45	1950	3.83	2015	4.22
5315	1797	2.97	1867	3.33	1934	3.70	2000	4.10	2063	4.50
5625	1855	3.23	1922	3.60	1987	3.97	2050	4.36	2112	4.77
5940	1915	3.51	1979	3.88	2042	4.26	2103	4.65	2163	5.06
6250	1978	3.81	2038	4.17	2098	4.55	2158	4.95	—	—

Std/Med Static 1072-2200 rpm, 3.0 maximum bhp

High Static 1072-2200 rpm, 5.0 maximum bhp

RAF150 — Standard/Medium Static — 12.5 Ton Horizontal Supply (rpm - vdc)

CFM	AVAILABLE EXTERNAL STATIC PRESSURE (in. wg)									
	0.2		0.4		0.6		0.8		1.0	
	rpm	vdc	rpm	vdc	rpm	vdc	rpm	vdc	rpm	vdc
3750	1072	4.8	1166	5.2	1266	5.7	1363	6.1	1454	6.6
4065	1148	5.1	1233	5.5	1324	6.0	1416	6.4	1504	6.8
4375	1226	5.5	1303	5.9	1386	6.2	1472	6.6	1556	7.0
4690	1304	5.9	1374	6.2	1451	6.5	1530	6.9	1610	7.3
5000	1383	6.2	1448	6.5	1518	6.9	1592	7.2	1667	7.5
5315	1463	6.6	1523	6.9	1588	7.2	1656	7.5	1726	7.8
5625	1543	7.0	1599	7.2	1659	7.5	1723	7.8	1789	8.1
5940	1623	7.3	1675	7.6	1732	7.8	1791	8.1	—	—
6250	1704	7.7	1753	7.9	1806	8.2	—	—	—	—

CFM	AVAILABLE EXTERNAL STATIC PRESSURE (in. wg)									
	1.2		1.4		1.6		1.8		2.0	
	rpm	vdc	rpm	vdc	rpm	vdc	rpm	vdc	rpm	vdc
3750	1540	7.0	1620	7.3	1694	7.7	1765	8.0	—	—
4065	1587	7.2	1666	7.5	1740	7.9	—	—	—	—
4375	1637	7.4	1713	7.8	1786	8.1	—	—	—	—
4690	1688	7.6	1763	8.0	—	—	—	—	—	—
5000	1741	7.9	—	—	—	—	—	—	—	—
5315	1797	8.1	—	—	—	—	—	—	—	—
5625	—	—	—	—	—	—	—	—	—	—
5940	—	—	—	—	—	—	—	—	—	—
6250	—	—	—	—	—	—	—	—	—	—

Std/Med Static 1072-2200 rpm

Fan data (cont)

RAF150 — High Static — 12.5 Ton Horizontal Supply (rpm - vdc)

CFM	AVAILABLE EXTERNAL STATIC PRESSURE (in. wg)									
	0.2		0.4		0.6		0.8		1.0	
	rpm	vdc	rpm	vdc	rpm	vdc	rpm	vdc	rpm	vdc
3750	1072	4.8	1166	5.2	1266	5.7	1363	6.1	1454	6.6
4065	1148	5.1	1233	5.5	1324	6.0	1416	6.4	1504	6.8
4375	1226	5.5	1303	5.9	1386	6.2	1472	6.6	1556	7.0
4690	1304	5.9	1374	6.2	1451	6.5	1530	6.9	1610	7.3
5000	1383	6.2	1448	6.5	1518	6.9	1592	7.2	1667	7.5
5315	1463	6.6	1523	6.9	1588	7.2	1656	7.5	1726	7.8
5625	1543	7.0	1599	7.2	1659	7.5	1723	7.8	1789	8.1
5940	1623	7.3	1675	7.6	1732	7.8	1791	8.1	1853	8.4
6250	1704	7.7	1753	7.9	1806	8.2	1861	8.4	1919	8.7

CFM	AVAILABLE EXTERNAL STATIC PRESSURE (in. wg)									
	1.2		1.4		1.6		1.8		2.0	
	rpm	vdc	rpm	vdc	rpm	vdc	rpm	vdc	rpm	vdc
3750	1540	7.0	1620	7.3	1694	7.7	1765	8.0	1833	8.3
4065	1587	7.2	1666	7.5	1740	7.9	1810	8.2	1877	8.5
4375	1637	7.4	1713	7.8	1786	8.1	1856	8.4	1922	8.7
4690	1688	7.6	1763	8.0	1834	8.3	1902	8.6	1968	8.9
5000	1741	7.9	1813	8.2	1883	8.5	1950	8.8	2015	9.1
5315	1797	8.1	1867	8.5	1934	8.8	2000	9.1	2063	9.4
5625	1855	8.4	1922	8.7	1987	9.0	2050	9.3	2112	9.6
5940	1915	8.7	1979	9.0	2042	9.3	2103	9.6	2163	9.8
6250	1978	9.0	2038	9.3	2098	9.5	2158	9.8	—	—

High Static 1072-2200 rpm

Fan data (cont)

RAF180 — 15 Ton Horizontal Supply (rpm - bhp)

CFM	AVAILABLE EXTERNAL STATIC PRESSURE (in. wg)									
	0.2		0.4		0.6		0.8		1.0	
	rpm	bhp	rpm	bhp	rpm	bhp	rpm	bhp	rpm	bhp
4500	1117	0.73	1198	0.90	1278	1.09	1358	1.31	1438	1.55
4875	1205	0.91	1279	1.09	1353	1.29	1427	1.51	1501	1.76
5250	1294	1.12	1363	1.30	1432	1.51	1500	1.74	1569	1.99
5625	1383	1.34	1448	1.54	1512	1.76	1576	1.99	1640	2.24
6000	1473	1.60	1534	1.80	1594	2.02	1654	2.26	1714	2.52
6375	1564	1.88	1621	2.09	1678	2.32	1734	2.56	1791	2.82
6750	1655	2.18	1709	2.40	1762	2.63	1816	2.88	1869	3.14
7125	1746	2.54	1797	2.76	1848	3.01	1899	3.26	1949	3.53
7500	1838	2.97	1886	3.21	1935	3.46	1983	3.73	2031	4.00

CFM	AVAILABLE EXTERNAL STATIC PRESSURE (in. wg)									
	1.2		1.4		1.6		1.8		2.0	
	rpm	bhp	rpm	bhp	rpm	bhp	rpm	bhp	rpm	bhp
4500	1516	1.82	1594	2.12	1670	2.43	1744	2.77	1816	3.13
4875	1575	2.03	1647	2.32	1719	2.64	1790	2.98	1858	3.33
5250	1638	2.26	1706	2.56	1773	2.87	1840	3.21	1905	3.56
5625	1704	2.51	1768	2.81	1832	3.12	1895	3.46	1957	3.81
6000	1775	2.79	1835	3.09	1894	3.39	1954	3.73	2013	4.08
6375	1848	3.09	1904	3.38	1961	3.70	2017	4.02	2073	4.37
6750	1923	3.43	1976	3.72	2030	4.03	2083	4.35	2136	4.69
7125	2000	3.81	2051	4.11	2101	4.42	2152	4.75	—	—
7500	2079	4.29	2127	4.60	2175	4.92	—	—	—	—

Std/Med Static 1117-2200 rpm, 3.0 maximum bhp

High Static 1117-2200 rpm, 5.0 maximum bhp

RAF180 — Standard/Medium Static — 15 Ton Horizontal Supply (rpm - vdc)

CFM	AVAILABLE EXTERNAL STATIC PRESSURE (in. wg)									
	0.2		0.4		0.6		0.8		1.0	
	rpm	vdc	rpm	vdc	rpm	vdc	rpm	vdc	rpm	vdc
4500	1117	5.0	1198	5.4	1278	5.7	1358	6.1	1438	6.5
4875	1205	5.4	1279	5.7	1353	6.1	1427	6.4	1501	6.8
5250	1294	5.8	1363	6.1	1432	6.5	1500	6.8	1569	7.1
5625	1383	6.2	1448	6.5	1512	6.8	1576	7.1	1640	7.4
6000	1473	6.6	1534	6.9	1594	7.2	1654	7.5	1714	7.8
6375	1564	7.1	1621	7.3	1678	7.6	1734	7.8	1791	8.1
6750	1655	7.5	1709	7.7	1762	8.0	1816	8.2	1869	8.5
7125	1746	7.9	1797	8.1	1848	8.4	—	—	—	—
7500	1838	8.3	—	—	—	—	—	—	—	—

CFM	AVAILABLE EXTERNAL STATIC PRESSURE (in. wg)									
	1.2		1.4		1.6		1.8		2.0	
	rpm	vdc	rpm	vdc	rpm	vdc	rpm	vdc	rpm	vdc
4500	1516	6.8	1594	7.2	1670	7.6	1744	7.9	—	—
4875	1575	7.1	1647	7.4	1719	7.8	1790	8.1	—	—
5250	1638	7.4	1706	7.7	1773	8.0	—	—	—	—
5625	1704	7.7	1768	8.0	—	—	—	—	—	—
6000	1775	8.0	—	—	—	—	—	—	—	—
6375	—	—	—	—	—	—	—	—	—	—
6750	—	—	—	—	—	—	—	—	—	—
7125	—	—	—	—	—	—	—	—	—	—
7500	—	—	—	—	—	—	—	—	—	—

Std/Med Static 1117-2200 rpm

Fan data (cont)

RAF180 — High Static — 15 Ton Horizontal Supply (rpm - vdc)

CFM	AVAILABLE EXTERNAL STATIC PRESSURE (in. wg)									
	0.2		0.4		0.6		0.8		1.0	
	rpm	vdc	rpm	vdc	rpm	vdc	rpm	vdc	rpm	vdc
4500	1117	5.0	1198	5.4	1278	5.7	1358	6.1	1438	6.5
4875	1205	5.4	1279	5.7	1353	6.1	1427	6.4	1501	6.8
5250	1294	5.8	1363	6.1	1432	6.5	1500	6.8	1569	7.1
5625	1383	6.2	1448	6.5	1512	6.8	1576	7.1	1640	7.4
6000	1473	6.6	1534	6.9	1594	7.2	1654	7.5	1714	7.8
6375	1564	7.1	1621	7.3	1678	7.6	1734	7.8	1791	8.1
6750	1655	7.5	1709	7.7	1762	8.0	1816	8.2	1869	8.5
7125	1746	7.9	1797	8.1	1848	8.4	1899	8.6	1949	8.8
7500	1838	8.3	1886	8.6	1935	8.8	1983	9.0	2031	9.2

CFM	AVAILABLE EXTERNAL STATIC PRESSURE (in. wg)									
	1.2		1.4		1.6		1.8		2.0	
	rpm	vdc	rpm	vdc	rpm	vdc	rpm	vdc	rpm	vdc
4500	1516	6.8	1594	7.2	1670	7.6	1744	7.9	1816	8.2
4875	1575	7.1	1647	7.4	1719	7.8	1790	8.1	1858	8.4
5250	1638	7.4	1706	7.7	1773	8.0	1840	8.3	1905	8.6
5625	1704	7.7	1768	8.0	1832	8.3	1895	8.6	1957	8.9
6000	1775	8.0	1835	8.3	1894	8.6	1954	8.9	2013	9.1
6375	1848	8.4	1904	8.6	1961	8.9	2017	9.2	2073	9.4
6750	1923	8.7	1976	9.0	2030	9.2	2083	9.5	2136	9.7
7125	2000	9.1	2051	9.3	2101	9.5	2152	9.8	—	—
7500	2079	9.4	2127	9.7	2175	9.9	—	—	—	—

High Static 1117-2200 rpm

Electrical data

Legend and Notes

Applicable for Electrical Data Tables on pages 103-130

LEGEND

BRKR	— Circuit Breaker
C.O.	— Convenience Outlet
FLA	— Full Load Amps
IFM	— Indoor Fan Motor
LRA	— Locked Rotor Amps
MCA	— Minimum Circuit Amps
P.E.	— Power Exhaust
PWRD C.O.	— Powered Convenience Outlet
RLA	— Rated Load Amps
SCCR	— Short Circuit Current Rating
UNPWR C.O.	— Unpowered Convenience Outlet

NOTES:

1. In compliance with NEC requirements for multi-motor and combination load equipment (refer to NEC Articles 430 and 440), the overcurrent protective device for the unit shall be fuse or HACR breaker. Canadian units may be fuse or circuit breaker.
2. For 208/230 v units, where one value is show it is the same for either 208 or 230 volts.
3. **Unbalanced 3-Phase Supply Voltage:** Never operate a motor where a phase imbalance in supply voltage is greater than 2%. Use the following formula to determine the percentage of voltage imbalance.

$$\% \text{ Voltage Imbalance} = 100 \times \frac{\text{max voltage deviation from average voltage}}{\text{average voltage}}$$

Example: Supply voltage is 230-3-60

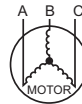

AB = 224-v
BC = 231-v
AC = 226-v

$$\text{Average Voltage} = \frac{(224 + 231 + 226)}{3} = \frac{681}{3} = 227$$

Determine maximum deviation from average voltage.

(AB) 227-224 = 3-v

(BC) 231-227 = 4-v

(AC) 227-226 = 1-v

Maximum deviation is 4-v.

Determine percent of voltage imbalance.

$$\% \text{ Voltage Imbalance} = 100 \times \frac{4}{227} = 1.76\%$$

This amount of phase imbalance is satisfactory as it is below the maximum allowable 2%.

IMPORTANT: If the supply voltage phase imbalance is more than 2%, contact your local electric utility company immediately.

Electrical data (cont)

RGF/RAF090-180 Cooling Electrical Data

RGF/RAF UNIT SIZE	V-Ph-Hz	UNIT VOLTAGE		COMP 1		COMP 2		OFM (EA)		STD SCCR kA	HIGH SCCR kA	IFM			COMBUSTION FAN MOTOR (48 SERIES ONLY)	POWER EXHAUST		
		RANGE		RLA	LRA	RLA	LRA	WATTS	FLA			TYPE	EFFCY AT FULL LOAD	FLA		FLA	KIT QTY	FLA (EA KIT)
		MIN	MAX															
090	208-3-60	187	253	12.2	120	12.2	120	325	1.5	5	10	MED	90%	6.4	0.48	1	3.8	
												HIGH	90%	7.5				
	230-3-60	187	253	12.2	120	12.2	120	325	1.5	5	10	MED	90%	6.4	0.48	1	3.8	
												HIGH	90%	7.5				
	460-3-60	414	506	6.4	49	6.4	49	325	0.8	5	10	MED	90%	3.0	0.25	1	3.8	
												HIGH	90%	3.5				
	575-3-60	518	633	5.1	4	5.1	4	325	0.6	5	—	MED	90%	2.5	0.24	1	3.8	
												HIGH	90%	3.0				
102	208-3-60	187	253	12.8	120	12.8	120	325	1.5	5	10	MED	90%	6.4	0.48	1	3.8	
												HIGH	90%	7.5				
	230-3-60	187	253	12.8	120	12.8	120	325	1.5	5	10	MED	90%	6.4	0.48	1	3.8	
												HIGH	90%	7.5				
	460-3-60	414	506	6.0	49	6.0	49	325	0.8	5	10	MED	90%	3.0	0.25	1	3.8	
												HIGH	90%	3.5				
	575-3-60	518	633	5.8	41	5.8	41	325	0.6	5	—	MED	90%	2.5	0.24	1	3.8	
												HIGH	90%	3.0				
120	208-3-60	187	253	18.6	16	18.6	16	325	1.5	5	10	MED	90%	6.4	0.48	1	3.8	
												HIGH	90%	12.6				
	230-3-60	187	253	18.6	16	18.6	16	325	1.5	5	10	MED	90%	6.4	0.48	1	3.8	
												HIGH	90%	12.6				
	460-3-60	414	506	8.3	58	8.3	58	325	0.8	5	10	MED	90%	3.0	0.25	1	3.8	
												HIGH	90%	5.6				
	575-3-60	518	633	7.7	48	7.7	48	325	0.6	5	—	MED	90%	2.5	0.24	1	3.8	
												HIGH	90%	4.6				
150	208-3-60	187	253	22.3	166	21.1	157	1070	7.4	5	—	MED	90%	7.5	0.48	1	3.8	
												HIGH	90%	12.6				
	230-3-60	187	253	22.3	166	21.1	157	1070	7.4	5	—	MED	90%	7.5	0.48	1	3.8	
												HIGH	90%	12.6				
	460-3-60	414	506	8.8	75	9.1	75	1070	7.4	5	—	MED	90%	3.5	0.25	1	3.8	
												HIGH	90%	5.6				
	575-3-60	518	633	7.2	54	7.7	48	1070	7.4	5	—	MED	90%	3.0	0.24	1	3.8	
												HIGH	90%	4.6				
180	208-3-60	187	253	28.5	255	21.1	157	280	1.5	5	10	MED	90%	7.5	0.48	1	3.8	
												HIGH	90%	12.6				
	230-3-60	187	253	28.5	255	21.1	157	280	1.5	5	10	MED	90%	7.5	0.48	1	3.8	
												HIGH	90%	12.6				
	460-3-60	414	506	13.4	123	9.1	75	280	0.8	5	10	MED	90%	3.5	0.25	1	3.8	
												HIGH	90%	5.6				
	575-3-60	518	633	10.7	94	7.7	48	280	0.6	5	—	MED	90%	3.0	0.24	1	3.8	
												HIGH	90%	4.6				

Electrical data (cont)

RGF090-180 MCA MOCP Electrical Data

RGF UNIT SIZE	NOM. V-Ph-Hz	IFM TYPE	STD SCCR kA	HIGH SCCR kA ^a	NO CONVENIENCE OUTLET OR UNPOWERED CONVENIENCE OUTLET							
					NO POWER EXHAUST				WITH POWER EXHAUST (powered from unit)			
					MCA	FUSE OR HACR BREAKER	DISCONNECT SIZE		MCA	FUSE OR HACR BREAKER	DISCONNECT SIZE	
							FLA	LRA			FLA	LRA
RGF090	208/230-3-60	STD/MED	5	10	37	45	39	257	41	50	43	261
		HIGH	5	10	38	50	40	259	42	50	45	263
	460-3-60	STD/MED	5	10	19	25	20	106	21	25	22	108
		HIGH	5	10	20	25	21	109	22	25	23	111
	575-3-60	STD/MED	5	—	16	20	16	90	19	25	20	20
		HIGH	5	—	16	20	17	91	20	25	21	21
RGF102	208/230-3-60	STD/MED	5	10	39	50	40	257	42	50	45	261
		HIGH	5	10	40	50	42	259	44	50	46	263
	460-3-60	STD/MED	5	10	19	20	19	106	20	25	21	108
		HIGH	5	10	19	25	20	109	21	25	22	111
	575-3-60	STD/MED	5	—	17	20	18	90	21	25	22	94
		HIGH	5	—	18	20	18	91	22	25	23	95
RGF120	208/230-3-60	STD/MED	5	10	52	60	54	49	56	60	58	53
		HIGH	5	10	58	70	61	58	62	70	65	62
	460-3-60	STD/MED	5	10	24	30	24	124	26	30	26	126
		HIGH	5	10	26	30	27	128	28	30	29	130
	575-3-60	STD/MED	5	—	21	25	22	104	25	30	26	108
		HIGH	5	—	24	30	24	106	27	30	29	110
RGF150	208/230-3-60	STD/MED	5	—	64	80	67	341	68	80	71	345
		HIGH	5	—	69	80	73	348	73	80	77	352
	460-3-60	STD/MED	5	—	32	40	33	164	33	40	35	166
		HIGH	5	—	34	40	36	165	35	40	38	167
	575-3-60	STD/MED	5	—	28	30	29	114	31	35	33	118
		HIGH	5	—	29	35	31	115	33	40	35	119
RGF180	208/230-3-60	STD/MED	5	10	69	80	71	435	73	80	75	439
		HIGH	5	10	74	100	77	442	78	100	81	446
	460-3-60	STD/MED	5	10	32	45	33	211	34	45	35	213
		HIGH	5	10	34	45	35	212	36	45	37	214
	575-3-60	STD/MED	5	—	26	30	27	153	30	40	31	157
		HIGH	5	—	28	35	29	154	32	40	33	158

NOTE(S):

a. High SCCR (Short Circuit Current Rating) is not available on units with Hot Gas Re-Heat system, powered convenience outlet, phase loss monitor, non-fused disconnect, or 575-v.

Electrical data (cont)

RGF090-180 MCA MOCPP Electrical Data (cont)

RGF UNIT SIZE	NOM. V-Ph-Hz	IFM TYPE	STD SCCR KA	WITH POWERED CONVENIENCE OUTLET							
				NO POWER EXHAUST				WITH POWER EXHAUST (powered from unit)			
				MCA	FUSE OR HACR BREAKER	DISCONNECT SIZE		MCA	FUSE OR HACR BREAKER	DISCONNECT SIZE	
						FLA	LRA			FLA	LRA
RGF090	208/230-3-60	STD/MED	5	42	50	44	262	46	50	49	266
		HIGH	5	43	50	46	264	47	50	50	268
	460-3-60	STD/MED	5	22	25	23	108	23	25	25	110
		HIGH	5	22	25	23	111	24	30	25	113
	575-3-60	STD/MED	5	17	20	18	92	21	25	22	22
		HIGH	5	18	20	19	93	22	25	23	23
RGF102	208/230-3-60	STD/MED	5	43	50	46	262	47	50	50	266
		HIGH	5	45	50	47	264	48	60	51	268
	460-3-60	STD/MED	5	21	25	22	108	23	25	24	110
		HIGH	5	21	25	22	111	23	25	24	113
	575-3-60	STD/MED	5	19	20	20	92	23	25	24	96
		HIGH	5	19	25	20	93	23	25	24	97
RGF120	208/230-3-60	STD/MED	5	57	70	59	54	60	70	63	58
		HIGH	5	63	80	66	63	67	80	71	67
	460-3-60	STD/MED	5	26	30	27	126	28	30	29	128
		HIGH	5	29	35	30	130	30	35	32	132
	575-3-60	STD/MED	5	23	30	24	106	27	30	28	110
		HIGH	5	25	30	26	108	29	35	31	112
RGF150	208/230-3-60	STD/MED	5	69	80	73	346	73	80	77	350
		HIGH	5	74	80	78	353	—	—	—	—
	460-3-60	STD/MED	5	34	40	36	166	36	40	38	168
		HIGH	5	36	40	38	167	38	45	40	169
	575-3-60	STD/MED	5	29	35	31	116	33	40	35	120
		HIGH	5	31	35	33	117	35	40	37	121
RGF180	208/230-3-60	STD/MED	5	74	100	76	440	78	100	81	444
		HIGH	5	79	100	82	447	83	100	87	451
	460-3-60	STD/MED	5	34	45	35	213	36	45	37	215
		HIGH	5	37	45	38	214	38	50	40	216
	575-3-60	STD/MED	5	28	35	29	155	32	40	33	159
		HIGH	5	30	35	30	156	33	40	35	160

Electrical data (cont)

RAF090 MCA MOCP Electrical Data

RAF UNIT SIZE	NOM. V-Ph-Hz	IFM TYPE	STD SCCR kA	HIGH SCCR kA ^a	ELECTRIC HEATER			NO CONVENIENCE OUTLET or UNPOWERED CONVENIENCE OUTLET							
					CRHEATER ****00	NOM (kW)	FLA	NO POWER EXHAUST				WITH POWER EXHAUST (powered from unit)			
								MCA	FUSE OR HACR BRKR	DISCONNECT SIZE		MCA	FUSE OR HACR BRKR	DISCONNECT SIZE	
										FLA	LRA			FLA	LRA
RAF090	208/230-3-60	STD/MED	5	10	—	—	—	37	45	39	257	41	50	43	261
					411A	7.8/10.4	21.7/25.0	37/40	45/45	39/39	257/257	41/44	50/50	43/43	261/261
					412A	12.0/16.0	33.4/38.5	50/57	50/60	46/52	257/257	55/61	60/70	50/56	261/261
					414A	18.8/25.0	52.1/60.1	74/84	80/90	67/76	257/257	78/88	80/90	72/81	261/261
					415A	24.0/32.0	66.7/77.0	92/105	100/110	84/96	257/257	97/109	100/110	88/100	261/261
		416A	31.8/42.4	88.4/102.0	119/136	125/150	109/125	257/257	124/141	125/150	113/129	261/261			
		HIGH	5	10	—	—	—	38	50	40	259	42	50	45	263
					411A	7.8/10.4	21.7/25.0	38/41	50/50	40/40	259/259	42/46	50/50	45/45	263/263
					412A	12.0/16.0	33.4/38.5	52/58	60/60	47/53	259/259	56/63	60/70	51/57	263/263
					414A	18.8/25.0	52.1/60.1	75/85	80/90	69/78	259/259	80/90	80/90	73/82	263/263
	415A				24.0/32.0	66.7/77.0	93/106	100/110	85/97	259/259	98/111	100/125	90/102	263/263	
	416A	31.8/42.4	88.4/102.0	120/137	125/150	110/126	259/259	125/142	125/150	115/130	263/263				
	460-3-60	STD/MED	5	10	—	—	—	19	25	20	106	21	25	22	108
					420A	15.0	18.0	27	30	24	106	29	30	26	108
					421A	25.0	30.1	42	45	38	106	44	45	40	108
					422A	33.0	39.7	54	60	49	106	56	60	51	108
					423A	41.7	50.2	67	70	61	106	69	70	63	108
		HIGH	5	10	—	—	—	20	25	21	109	22	25	23	111
					420A	15.0	18.0	27	30	25	109	30	30	27	111
					421A	25.0	30.1	42	45	39	109	45	45	41	111
422A					33.0	39.7	54	60	50	109	57	60	52	111	
423A					41.7	50.2	68	70	62	109	70	70	64	111	
575-3-60	STD/MED	5	—	—	—	—	16	20	16	90	19	25	20	94	
				425A	18.0	17.3	25	25	23	90	30	30	27	94	
				427A	36.0	34.6	47	50	43	90	52	60	47	94	
	HIGH	5	—	—	—	—	16	20	17	91	20	25	21	95	
				425A	18.0	17.3	26	30	23	91	31	35	28	95	
				427A	36.0	34.6	47	50	43	91	52	60	48	95	

NOTE(S):

- a. High SCCR (Short Circuit Current Rating) is not available on units with Hot Gas Re-Heat system, powered convenience outlet, phase loss monitor, non-fused disconnect, or 575-v.

Electrical data (cont)

RAF090 MCA MOCP Electrical Data (cont)

RAF UNIT SIZE	NOM. V-Ph-Hz	IFM TYPE	STD SCCR kA	ELECTRIC HEATER			WITH POWERED CONVENIENCE OUTLET										
				CRHEATER ****00	NOM (kW)	FLA	NO POWER EXHAUST				WITH POWER EXHAUST (powered from unit)						
							MCA	FUSE OR HACR BRKR	DISCONNECT SIZE		MCA	FUSE OR HACR BRKR	DISCONNECT SIZE				
									FLA	LRA			FLA	LRA			
RAF090	208/230-3-60	STD/MED	5	—	—	—	42	50	44	262	46	50	49	266			
				411A	7.8/10.4	21.7/25.0	42/46	50/50	44/44	262/262	46/50	50/60	49/49	266/266			
				412A	12.0/16.0	33.4/38.5	56/63	60/70	51/57	262/262	61/67	70/70	56/62	266/266			
				414A	18.8/25.0	52.1/60.1	80/90	80/90	73/82	262/262	84/94	90/100	77/86	266/266			
				415A	24.0/32.0	66.7/77.0	98/111	100/125	90/101	262/262	103/115	110/125	94/106	266/266			
				416A	31.8/42.4	88.4/102.0	125/142	125/150	115/130	262/262	130/147	150/150	119/135	266/266			
		HIGH	5	—	—	—	43	50	46	264	47	50	50	268			
				411A	7.8/10.4	21.7/25.0	43/47	50/50	46/46	264/264	48/52	50/60	50/50	268/268			
				412A	12.0/16.0	33.4/38.5	58/64	60/70	53/58	264/264	62/69	70/70	57/63	268/268			
				414A	18.8/25.0	52.1/60.1	81/91	90/100	74/83	264/264	86/96	90/100	78/88	268/268			
				415A	24.0/32.0	66.7/77.0	99/112	100/125	91/103	264/264	104/117	110/125	95/107	268/268			
				416A	31.8/42.4	88.4/102.0	126/143	150/150	116/131	264/264	131/148	150/150	120/136	268/268			
				460-3-60	STD/MED	5	—	—	—	22	25	23	108	23	25	25	110
							420A	15.0	18.0	29	30	27	108	32	35	29	110
	421A	25.0	30.1				45	45	41	108	47	50	43	110			
	422A	33.0	39.7				57	60	52	108	59	60	54	110			
	423A	41.7	50.2				70	70	64	108	72	80	66	110			
	—	—	—				22	25	23	111	24	30	25	113			
	HIGH	5	420A		15.0	18.0	30	30	27	111	32	35	29	113			
			421A		25.0	30.1	45	45	41	111	47	50	43	113			
			422A		33.0	39.7	57	60	52	111	59	60	54	113			
			423A		41.7	50.2	70	70	64	111	73	80	66	113			
			575-3-60		STD/MED	5	—	—	—	17	20	18	92	21	25	22	96
							425A	18.0	17.3	27	30	25	92	32	35	29	96
							427A	36.0	34.6	49	50	45	92	54	60	49	96
					HIGH	5	—	—	—	18	20	19	93	22	25	23	97
	425A	18.0		17.3			28	30	25	93	33	35	30	97			
	427A	36.0		34.6			50	50	45	93	54	60	50	97			

Electrical data (cont)

RAF102 MCA MOCP Electrical Data

RAF UNIT SIZE	NOM. V-Ph-Hz	IFM TYPE	STD SCCR kA	HIGH SCCR kA ^a	ELECTRIC HEATER			NO CONVENIENCE OUTLET or UNPOWERED CONVENIENCE OUTLET							
					CRHEATER ****00	NOM (kW)	FLA	NO POWER EXHAUST				WITH POWER EXHAUST (powered from unit)			
								MCA	FUSE OR HACR BRKR	DISCONNECT SIZE		MCA	FUSE OR HACR BRKR	DISCONNECT SIZE	
										FLA	LRA			FLA	LRA
RAF102	208/230-3-60	STD/MED	5	10	—	—	—	39	50	40	257	42	50	45	261
					411A	7.8/10.4	21.7/25.0	39/40	50/50	40/40	257/257	42/44	50/50	45/45	261/261
					412A	12.0/16.0	33.4/38.5	50/57	50/60	46/52	257/257	55/61	60/70	50/56	261/261
					414A	18.8/25.0	52.1/60.1	74/84	80/90	67/76	257/257	78/88	80/90	72/81	261/261
					415A	24.0/32.0	66.7/77.0	92/105	100/110	84/96	257/257	97/109	100/110	88/100	261/261
		416A	31.8/42.4	88.4/102.0	119/136	125/150	109/125	257/257	124/141	125/150	113/129	261/261			
		HIGH	5	10	—	—	—	40	50	42	259	44	50	46	263
					411A	7.8/10.4	21.7/25.0	40/41	50/50	42/42	259/259	44/46	50/50	46/46	263/263
					412A	12.0/16.0	33.4/38.5	52/58	60/60	47/53	259/259	56/63	60/70	51/57	263/263
					414A	18.8/25.0	52.1/60.1	75/85	80/90	69/78	259/259	80/90	80/90	73/82	263/263
	415A				24.0/32.0	66.7/77.0	93/106	100/110	85/97	259/259	98/111	100/125	90/102	263/263	
	416A	31.8/42.4	88.4/102.0	120/137	125/150	110/126	259/259	125/142	125/150	115/130	263/263				
	460-3-60	STD/MED	5	10	—	—	—	19	20	19	106	20	25	21	108
					420A	15.0	18.0	27	30	24	106	29	30	26	108
					421A	25.0	30.1	42	45	38	106	44	45	40	108
					422A	33.0	39.7	54	60	49	106	56	60	51	108
					423A	41.7	50.2	67	70	61	106	69	70	63	108
		HIGH	5	10	—	—	—	19	25	20	109	21	25	22	111
					420A	15.0	18.0	27	30	25	109	30	30	27	111
					421A	25.0	30.1	42	45	39	109	45	45	41	111
422A					33.0	39.7	54	60	50	109	57	60	52	111	
423A					41.7	50.2	68	70	62	109	70	70	64	111	
575-3-60	STD/MED	5	—	—	—	—	17	20	18	90	21	25	22	94	
				425A	18.0	17.3	25	25	23	90	30	30	27	94	
				427A	36.0	34.6	47	50	43	90	52	60	47	94	
	HIGH	5	—	—	—	—	18	20	18	91	22	25	23	95	
				425A	18.0	17.3	26	30	23	91	31	35	28	95	
				427A	36.0	34.6	47	50	43	91	52	60	48	95	

NOTE(S):

- a. High SCCR (Short Circuit Current Rating) is not available on units with Hot Gas Re-Heat system, powered convenience outlet, phase loss monitor, non-fused disconnect, or 575-v.

Electrical data (cont)

RAF102 MCA MOCP Electrical Data (cont)

RAF UNIT SIZE	NOM. V-Ph-Hz	IFM TYPE	STD SCCR kA	ELECTRIC HEATER			WITH POWERED CONVENIENCE OUTLET							
				CRHEATER ****00	NOM (kW)	FLA	NO POWER EXHAUST				WITH POWER EXHAUST (powered from unit)			
							MCA	FUSE OR HACR BRKR	DISCONNECT SIZE		MCA	FUSE OR HACR BRKR	DISCONNECT SIZE	
									FLA	LRA			FLA	LRA
RAF102	208/230-3-60	STD/MED	5	—	—	—	43	50	46	262	47	50	50	266
				411A	7.8/10.4	21.7/25.0	43/46	50/50	46/46	262/262	47/50	50/60	50/50	266/266
				412A	12.0/16.0	33.4/38.5	56/63	60/70	51/57	262/262	61/67	70/70	56/62	266/266
				414A	18.8/25.0	52.1/60.1	80/90	80/90	73/82	262/262	84/94	90/100	77/86	266/266
				415A	24.0/32.0	66.7/77.0	98/111	100/125	90/101	262/262	103/115	110/125	94/106	266/266
		416A	31.8/42.4	88.4/102.0	125/142	125/150	115/130	262/262	130/147	150/150	119/135	266/266		
		HIGH	5	—	—	—	45	50	47	264	48	60	51	268
				411A	7.8/10.4	21.7/25.0	45/47	50/50	47/47	264/264	48/52	60/60	51/51	268/268
				412A	12.0/16.0	33.4/38.5	58/64	60/70	53/58	264/264	62/69	70/70	57/63	268/268
				414A	18.8/25.0	52.1/60.1	81/91	90/100	74/83	264/264	86/96	90/100	78/88	268/268
	415A			24.0/32.0	66.7/77.0	99/112	100/125	91/103	264/264	104/117	110/125	95/107	268/268	
	416A	31.8/42.4	88.4/102.0	126/143	150/150	116/131	264/264	131/148	150/150	120/136	268/268			
	460-3-60	STD/MED	5	—	—	—	21	25	22	108	23	25	24	110
				420A	15.0	18.0	29	30	27	108	32	35	29	110
				421A	25.0	30.1	45	45	41	108	47	50	43	110
				422A	33.0	39.7	57	60	52	108	59	60	54	110
				423A	41.7	50.2	70	70	64	108	72	80	66	110
		HIGH	5	—	—	—	21	25	22	111	23	25	24	113
				420A	15.0	18.0	30	30	27	111	32	35	29	113
				421A	25.0	30.1	45	45	41	111	47	50	43	113
				422A	33.0	39.7	57	60	52	111	59	60	54	113
				423A	41.7	50.2	70	70	64	111	73	80	66	113
	575-3-60	STD/MED	5	—	—	—	19	20	20	92	23	25	24	96
				425A	18.0	17.3	27	30	25	92	32	35	29	96
				427A	36.0	34.6	49	50	45	92	54	60	49	96
		HIGH	5	—	—	—	19	25	20	93	23	25	24	97
				425A	18.0	17.3	28	30	25	93	33	35	30	97
				427A	36.0	34.6	50	50	45	93	54	60	50	97

Electrical data (cont)

RAF120 MCA MOCP Electrical Data

RAF UNIT SIZE	NOM. V-Ph-Hz	IFM TYPE	STD SCCR kA	HIGH SCCR kA ^a	ELECTRIC HEATER			NO CONVENIENCE OUTLET or UNPOWERED CONVENIENCE OUTLET							
					CRHEATER ****00	NOM (kW)	FLA	NO POWER EXHAUST				WITH POWER EXHAUST (powered from unit)			
								MCA	FUSE OR HACR BRKR	DISCONNECT SIZE		MCA	FUSE OR HACR BRKR	DISCONNECT SIZE	
										FLA	LRA			FLA	LRA
RAF120	208/230-3-60	STD/MED	5	10	—	—	—	52	60	54	327	56	60	58	331
					411A	7.8/10.4	21.7/25.0	52/52	60/60	54/54	327/327	56/56	60/60	58/58	331/331
					412A	12.0/16.0	33.4/38.5	52/57	60/60	54/54	327/327	56/61	60/70	58/58	331/331
					415A	24.0/32.0	66.7/77.0	92/105	100/110	84/96	327/327	97/109	100/110	88/100	331/331
					416A	31.8/42.4	88.4/102.0	119/136	125/150	109/125	327/327	124/141	125/150	113/129	331/331
		417A	37.6/50.0	104.2/120.3	139/129	150/150	127/146	327/327	143/134	150/150	132/150	331/331			
		HIGH	5	10	—	—	—	58	70	61	336	62	70	65	340
					411A	7.8/10.4	21.7/25.0	58/58	70/70	61/61	336/336	62/62	70/70	65/65	340/340
					412A	12.0/16.0	33.4/38.5	58/64	70/70	61/61	336/336	63/69	70/70	65/65	340/340
					415A	24.0/32.0	66.7/77.0	100/112	100/125	91/103	336/336	104/117	110/125	96/107	340/340
	416A				31.8/42.4	88.4/102.0	127/144	150/150	116/132	336/336	131/148	150/150	121/136	340/340	
	417A	37.6/50.0	104.2/120.3	146/137	150/150	134/153	336/336	151/141	175/175	139/157	340/340				
	460-3-60	STD/MED	5	10	—	—	—	24	30	24	124	26	30	26	126
					420A	15.0	18.0	27	30	24	124	29	30	26	126
					422A	33.0	39.7	54	60	49	124	56	60	51	126
					423A	41.7	50.2	67	70	61	124	69	70	63	126
					424A	50.0	60.1	64	70	73	124	67	70	75	126
		HIGH	5	10	—	—	—	26	30	27	128	28	30	29	130
					420A	15.0	18.0	30	30	27	128	32	35	29	130
					422A	33.0	39.7	57	60	52	128	59	60	54	130
					423A	41.7	50.2	70	70	64	128	72	80	66	130
					424A	50.0	60.1	68	80	76	128	70	80	78	130
	575-3-60	STD/MED	5	—	—	—	—	21	25	22	104	25	30	26	108
					425A	18.0	17.3	25	25	23	104	30	30	27	108
427A					36.0	34.6	47	50	43	104	52	60	47	108	
428A					50.0	48.1	52	60	58	104	56	60	63	108	
HIGH		5	—	—	—	—	24	30	24	106	27	30	29	110	
				425A	18.0	17.3	28	30	25	106	33	35	30	110	
				427A	36.0	34.6	49	50	45	106	54	60	49	110	
				428A	50.0	48.1	54	60	61	106	59	60	65	110	

NOTE(S):

- a. High SCCR (Short Circuit Current Rating) is not available on units with Hot Gas Re-Heat system, powered convenience outlet, phase loss monitor, non-fused disconnect, or 575-v.

Electrical data (cont)

RAF120 MCA MOCP Electrical Data (cont)

RAF UNIT SIZE	NOM. V-Ph-Hz	IFM TYPE	STD SCCR kA	ELECTRIC HEATER			WITH POWERED CONVENIENCE OUTLET							
				CRHEATER ****00	NOM (kW)	FLA	NO POWER EXHAUST				WITH POWER EXHAUST (powered from unit)			
							MCA	FUSE OR HACR BRKR	DISCONNECT SIZE		MCA	FUSE OR HACR BRKR	DISCONNECT SIZE	
									FLA	LRA			FLA	LRA
RAF120	208/230-3-60	STD/MED	5	—	—	—	57	70	59	332	60	70	63	336
				411A	7.8/10.4	21.7/25.0	57/57	70/70	59/59	332/332	60/60	70/70	63/63	336/336
				412A	12.0/16.0	33.4/38.5	57/63	70/70	59/59	332/332	61/67	70/70	63/63	336/336
				415A	24.0/32.0	66.7/77.0	98/111	100/125	90/101	332/332	103/115	110/125	94/106	336/336
				416A	31.8/42.4	88.4/102.0	125/142	125/150	115/130	332/332	130/147	150/150	119/135	336/336
		417A	37.6/50.0	104.2/120.3	145/135	150/150	133/151	332/332	149/140	150/150	137/156	336/336		
		HIGH	5	—	—	—	63	80	66	341	67	80	71	345
				411A	7.8/10.4	21.7/25.0	63/63	80/80	66/66	341/341	67/67	80/80	71/71	345/345
				412A	12.0/16.0	33.4/38.5	64/70	80/80	66/66	341/341	69/75	80/80	71/71	345/345
				415A	24.0/32.0	66.7/77.0	106/118	110/125	97/109	341/341	110/123	110/125	101/113	345/345
	416A			31.8/42.4	88.4/102.0	133/150	150/150	122/137	341/341	137/154	150/175	126/142	345/345	
	417A	37.6/50.0	104.2/120.3	152/143	175/175	140/158	341/341	157/147	175/175	144/163	345/345			
	460-3-60	STD/MED	5	—	—	—	26	30	27	126	28	30	29	128
				420A	15.0	18.0	29	30	27	126	32	35	29	128
				422A	33.0	39.7	57	60	52	126	59	60	54	128
				423A	41.7	50.2	70	70	64	126	72	80	66	128
				424A	50.0	60.1	67	70	75	126	69	80	77	128
		HIGH	5	—	—	—	29	35	30	130	30	35	32	132
				420A	15.0	18.0	33	35	30	130	35	35	32	132
				422A	33.0	39.7	60	60	55	130	62	70	57	132
				423A	41.7	50.2	73	80	67	130	75	80	69	132
				424A	50.0	60.1	70	80	78	130	73	80	80	132
	575-3-60	STD/MED	5	—	—	—	23	30	24	106	27	30	28	110
				425A	18.0	17.3	27	30	25	106	32	35	29	110
				427A	36.0	34.6	49	50	45	106	54	60	49	110
				428A	50.0	48.1	54	60	60	106	59	60	65	110
		HIGH	5	—	—	—	25	30	26	108	29	35	31	112
				425A	18.0	17.3	30	30	27	108	35	35	32	112
427A				36.0	34.6	52	60	47	108	56	60	51	112	
428A				50.0	48.1	56	60	63	108	61	70	67	112	

Electrical data (cont)

RAF150 MCA MOCOP Electrical Data

RAF UNIT SIZE	NOM. V-Ph-Hz	IFM TYPE	STD SCCR kA	ELECTRIC HEATER			NO CONVENIENCE OUTLET or UNPOWERED CONVENIENCE OUTLET							
				CRHEATER ****00	NOM (kW)	FLA	NO POWER EXHAUST				WITH POWER EXHAUST (powered from unit)			
							MCA	FUSE OR HACR BRKR	DISCONNECT SIZE		MCA	FUSE OR HACR BRKR	DISCONNECT SIZE	
									FLA	LRA			FLA	LRA
RAF150	208/230-3-60	STD/MED	5	—	—	—	64	80	67	341	68	80	71	345
				411A	7.8/10.4	21.7/25.0	64/64	80/80	67/67	341/341	68/68	80/80	71/71	345/345
				412A	12.0/16.0	33.4/38.5	64/64	80/80	67/67	341/341	68/68	80/80	71/71	345/345
				415A	24.0/32.0	66.7/77.0	93/106	100/110	85/97	341/341	98/111	100/125	90/102	345/345
				416A	31.8/42.4	88.4/102.0	120/137	125/150	110/126	341/341	125/142	125/150	115/130	345/345
		417A	37.6/50.0	104.2/120.3	140/130	150/150	128/147	341/341	145/135	150/150	133/151	345/345		
		HIGH	5	—	—	—	69	80	73	348	73	80	77	352
				411A	7.8/10.4	21.7/25.0	69/69	80/80	73/73	348/348	73/73	80/80	77/77	352/352
				412A	12.0/16.0	33.4/38.5	69/69	80/80	73/73	348/348	73/73	80/80	77/77	352/352
				415A	24.0/32.0	66.7/77.0	100/112	100/125	91/103	348/348	104/117	110/125	96/107	352/352
	416A			31.8/42.4	88.4/102.0	127/144	150/150	116/132	348/348	131/148	150/150	121/136	352/352	
	417A	37.6/50.0	104.2/120.3	146/137	150/150	134/153	348/348	151/141	175/175	139/157	352/352			
	460-3-60	STD/MED	5	—	—	—	32	40	33	164	33	40	35	166
				420A	15.0	18.0	32	40	33	164	33	40	35	166
				422A	33.0	39.7	54	60	50	164	57	60	52	166
				423A	41.7	50.2	68	70	62	164	70	70	64	166
				424A	50.0	60.1	65	70	73	164	67	70	75	166
		HIGH	5	—	—	—	34	40	36	165	35	40	38	167
				420A	15.0	18.0	34	40	36	165	35	40	38	167
				422A	33.0	39.7	57	60	52	165	59	60	54	167
				423A	41.7	50.2	70	70	64	165	72	80	66	167
				424A	50.0	60.1	68	80	76	165	70	80	78	167
	575-3-60	STD/MED	5	—	—	—	28	30	29	114	31	35	33	118
				425A	18.0	17.3	28	30	29	114	31	35	33	118
427A				36.0	34.6	47	50	43	114	52	60	48	118	
428A				50.0	48.1	52	60	59	114	57	60	63	118	
HIGH		5	—	—	—	29	35	31	115	33	40	35	119	
			425A	18.0	17.3	29	35	31	115	33	40	35	119	
			427A	36.0	34.6	49	50	45	115	54	60	49	119	
			428A	50.0	48.1	54	60	61	115	59	60	65	119	

Electrical data (cont)

RAF150 MCA MOCP Electrical Data (cont)

RAF UNIT SIZE	NOM. V-Ph-Hz	IFM TYPE	STD SCCR kA	ELECTRIC HEATER			WITH POWERED CONVENIENCE OUTLET							
				CRHEATER ****00	NOM (kW)	FLA	NO POWER EXHAUST				WITH POWER EXHAUST (powered from unit)			
							MCA	FUSE OR HACR BRKR	DISCONNECT SIZE		MCA	FUSE OR HACR BRKR	DISCONNECT SIZE	
									FLA	LRA			FLA	LRA
RAF150	208/230-3-60	STD/MED	5	—	—	—	69	80	73	346	73	80	77	350
				411A	7.8/10.4	21.7/25.0	69/69	80/80	73/73	346/346	73/73	80/80	77/77	350/350
				412A	12.0/16.0	33.4/38.5	69/69	80/80	73/73	346/346	73/73	80/80	77/77	350/350
				415A	24.0/32.0	66.7/77.0	99/112	100/125	91/103	346/346	104/117	110/125	95/107	350/350
				416A	31.8/42.4	88.4/102.0	126/143	150/150	116/131	346/346	131/148	150/150	120/136	350/350
		417A	37.6/50.0	104.2/120.3	146/136	150/150	134/152	346/346	151/141	175/150	138/157	350/350		
		HIGH	5	—	—	—	74	80	78	353	78	90	83	357
				411A	7.8/10.4	21.7/25.0	74/74	80/80	78/78	353/353	78/78	90/90	83/83	357/357
				412A	12.0/16.0	33.4/38.5	74/74	80/80	78/78	353/353	78/78	90/90	83/83	357/357
				415A	24.0/32.0	66.7/77.0	106/118	110/125	97/109	353/353	110/123	110/125	101/113	357/357
	416A			31.8/42.4	88.4/102.0	133/150	150/150	122/137	353/353	137/154	150/175	126/142	357/357	
	417A	37.6/50.0	104.2/120.3	152/143	175/175	140/158	353/353	157/147	175/175	144/163	357/357			
	460-3-60	STD/MED	5	—	—	—	34	40	36	166	36	40	38	168
				420A	15.0	18.0	34	40	36	166	36	40	38	168
				422A	33.0	39.7	57	60	52	166	59	60	54	168
				423A	41.7	50.2	70	70	64	166	73	80	66	168
				424A	50.0	60.1	68	80	76	166	70	80	78	168
		HIGH	5	—	—	—	36	40	38	167	38	45	40	169
				420A	15.0	18.0	36	40	38	167	38	45	40	169
				422A	33.0	39.7	60	60	55	167	62	70	57	169
				423A	41.7	50.2	73	80	67	167	75	80	69	169
				424A	50.0	60.1	70	80	78	167	73	80	80	169
	575-3-60	STD/MED	5	—	—	—	29	35	31	116	33	40	35	120
				425A	18.0	17.3	29	35	31	116	33	40	35	120
				427A	36.0	34.6	50	50	45	116	54	60	50	120
				428A	50.0	48.1	54	60	61	116	59	60	65	120
		HIGH	5	—	—	—	31	35	33	117	35	40	37	121
				425A	18.0	17.3	31	35	33	117	35	40	37	121
427A				36.0	34.6	52	60	47	117	56	60	51	121	
428A				50.0	48.1	56	60	63	117	61	70	67	121	

Electrical data (cont)

RAF180 MCA MOCP Electrical Data

RAF UNIT SIZE	NOM. V-Ph-Hz	IFM TYPE	STD SCCR KA	HIGH SCCR KA ^a	ELECTRIC HEATER			NO CONVENIENCE OUTLET or UNPOWERED CONVENIENCE OUTLET							
					CRHEATER ****00	NOM (kW)	FLA	NO POWER EXHAUST				WITH POWER EXHAUST (powered from unit)			
								MCA	FUSE OR HACR BRKR	DISCONNECT SIZE		MCA	FUSE OR HACR BRKR	DISCONNECT SIZE	
										FLA	LRA			FLA	LRA
RAF180	208/230-3-60	STD/MED	5	10	—	—	—	69	80	71	435	73	80	75	439
					412A	12.0/16.0	33.4/38.5	69/69	80/80	71/71	435/435	73/73	80/80	75/75	439/439
					414A	18.8/25.0	52.1/60.1	75/85	80/90	71/78	435/435	80/90	80/100	75/82	439/439
					415A	24.0/32.0	66.7/77.0	93/106	100/110	85/97	435/435	98/111	100/125	90/102	439/439
					416A	31.8/42.4	88.4/102.0	120/137	125/150	110/126	435/435	125/142	125/150	115/130	439/439
					417A	37.6/50.0	104.2/120.3	140/130	150/150	128/147	435/435	145/135	150/150	133/151	439/439
		451A	50.3/67.0	139.7/161.2	150/171	175/200	169/194	435/435	154/176	175/200	174/198	439/439			
		—	—	—	74	100	77	442	78	100	81	446			
		412A	12.0/16.0	33.4/38.5	74/74	100/100	77/77	442/442	78/78	100/100	81/81	446/446			
		414A	18.8/25.0	52.1/60.1	81/91	100/100	77/84	442/442	86/96	100/100	81/88	446/446			
		415A	24.0/32.0	66.7/77.0	100/112	100/125	91/103	442/442	104/117	110/125	96/107	446/446			
		416A	31.8/42.4	88.4/102.0	127/144	150/150	116/132	442/442	131/148	150/150	121/136	446/446			
	417A	37.6/50.0	104.2/120.3	146/137	150/150	134/153	442/442	151/141	175/175	139/157	446/446				
	451A	50.3/67.0	139.7/161.2	156/177	175/200	175/200	442/442	161/182	175/200	180/204	446/446				
	—	—	—	32	45	33	211	34	45	35	213				
	420A	15.0	18.0	32	45	33	211	34	45	35	213				
	421A	25.0	30.1	42	45	39	211	45	45	41	213				
	422A	33.0	39.7	54	60	50	211	57	60	52	213				
	423A	41.7	50.2	68	70	62	211	70	70	64	213				
	424A	50.0	60.1	65	70	73	211	67	70	75	213				
	452A	67.0	80.6	85	90	97	211	88	100	99	213				
	—	—	—	34	45	35	212	36	45	37	214				
	420A	15.0	18.0	34	45	35	212	36	45	37	214				
	421A	25.0	30.1	45	45	41	212	47	50	43	214				
	422A	33.0	39.7	57	60	52	212	59	60	54	214				
	423A	41.7	50.2	70	70	64	212	72	80	66	214				
	424A	50.0	60.1	68	80	76	212	70	80	78	214				
	452A	67.0	80.6	88	100	99	212	90	100	101	214				
	—	—	—	26	30	27	153	30	40	31	157				
	425A	18.0	17.3	26	30	27	153	31	40	31	157				
427A	36.0	34.6	47	50	43	153	52	60	48	157					
428A	50.0	48.1	52	60	59	153	57	60	63	157					
453A	67.0	64.5	69	80	78	153	73	80	82	157					
—	—	—	28	35	29	154	32	40	33	158					
425A	18.0	17.3	28	35	29	154	33	40	33	158					
427A	36.0	34.6	49	50	45	154	54	60	49	158					
428A	50.0	48.1	54	60	61	154	59	60	65	158					
453A	67.0	64.5	71	80	79	154	75	80	84	158					

NOTE(S):

a. High SCCR (Short Circuit Current Rating) is not available on units with Hot Gas Re-Heat system, powered convenience outlet, phase loss monitor, non-fused disconnect, or 575-v.

Electrical data (cont)

RAF180 MCA MOCP Electrical Data (cont)

RAF UNIT SIZE	NOM. V-Ph-Hz	IFM TYPE	STD SCCR KA	ELECTRIC HEATER			WITH POWERED CONVENIENCE OUTLET							
				CRHEATER ****00	NOM (kW)	FLA	NO POWER EXHAUST				WITH POWER EXHAUST (powered from unit)			
							MCA	FUSE OR HACR BRKR	DISCONNECT SIZE		MCA	FUSE OR HACR BRKR	DISCONNECT SIZE	
									FLA	LRA			FLA	LRA
RAF180	208/230-3-60	STD/MED	5	—	—	—	74	100	76	440	78	100	81	444
				412A	12.0/16.0	33.4/38.5	74/74	100/100	76/76	440/440	78/78	100/100	81/81	444/444
				414A	18.8/25.0	52.1/60.1	81/91	100/100	76/83	440/440	86/96	100/100	81/88	444/444
				415A	24.0/32.0	66.7/77.0	99/112	100/125	91/103	440/440	104/117	110/125	95/107	444/444
				416A	31.8/42.4	88.4/102.0	126/143	150/150	116/131	440/440	131/148	150/150	120/136	444/444
				417A	37.6/50.0	104.2/120.3	146/136	150/150	134/152	440/440	151/141	175/150	138/157	444/444
		451A	50.3/67.0	139.7/161.2	156/177	175/200	175/200	440/440	160/182	175/200	179/204	444/444		
		HIGH	5	—	—	—	79	100	82	447	83	100	87	451
				412A	12.0/16.0	33.4/38.5	79/79	100/100	82/82	447/447	83/83	100/100	87/87	451/451
				414A	18.8/25.0	52.1/60.1	87/97	100/100	82/89	447/447	92/102	100/110	87/93	451/451
				415A	24.0/32.0	66.7/77.0	106/118	110/125	97/109	447/447	110/123	110/125	101/113	451/451
				416A	31.8/42.4	88.4/102.0	133/150	150/150	122/137	447/447	137/154	150/175	126/142	451/451
	417A			37.6/50.0	104.2/120.3	152/143	175/175	140/158	447/447	157/147	175/175	144/163	451/451	
	460-3-60	STD/MED	5	—	—	—	34	45	35	213	36	45	37	215
				420A	15.0	18.0	34	45	35	213	36	45	37	215
				421A	25.0	30.1	45	45	41	213	47	50	43	215
				422A	33.0	39.7	57	60	52	213	59	60	54	215
				423A	41.7	50.2	70	70	64	213	73	80	66	215
				424A	50.0	60.1	68	80	76	213	70	80	78	215
		452A	67.0	80.6	88	100	99	213	90	100	101	215		
		HIGH	5	—	—	—	37	45	38	214	38	50	40	216
				420A	15.0	18.0	37	45	38	214	38	50	40	216
				421A	25.0	30.1	48	50	44	214	50	50	46	216
				422A	33.0	39.7	60	60	55	214	62	70	57	216
				423A	41.7	50.2	73	80	67	214	75	80	69	216
	424A			50.0	60.1	70	80	78	214	73	80	80	216	
	575-3-60	STD/MED	5	—	—	—	28	35	29	155	32	40	33	159
				425A	18.0	17.3	28	35	29	155	33	40	33	159
				427A	36.0	34.6	50	50	45	155	54	60	50	159
				428A	50.0	48.1	54	60	61	155	59	60	65	159
453A				67.0	64.5	71	80	80	155	76	80	84	159	
—				—	—	30	35	30	156	33	40	35	160	
HIGH		5	425A	18.0	17.3	30	35	30	156	35	40	35	160	
			427A	36.0	34.6	52	60	47	156	56	60	51	160	
			428A	50.0	48.1	56	60	63	156	61	70	67	160	
			453A	67.0	64.5	73	80	81	156	78	80	86	160	

Electrical data (cont)

RAF090 Electric Heat Data — Without Non-fused Disconnect

RAF UNIT SIZE	NOM. V-Ph-Hz	IFM TYPE	ELECTRIC HEATER PART NUMBER	NOM (kW)	STD SCCR kA	HIGH SCCR kA ^a	APPLICATION (kW)	APPLICATION OUTPUT (MBH)	SINGLE POINT OR JUNCTION KIT PART NUMBER CRSINGLEXXXA00				
									NO C.O. OR UNPOWERED C.O.		WITH PWRD C.O.		
									NO P.E.	WITH P.E. (pwrd fr/unit)	NO P.E	WITH P.E. (pwrd fr/unit)	
RAF090	208/230-3-60	STD/ MED	CRHEATER411A00	10.4	5	10	7.8/9.6	26.7/32.6	042	042	042	042	
			CRHEATER412A00	16.0	5	10	12.0/14.7	41.0/50.1	042	043	043	043	
			CRHEATER414A00	25.0	5	10	18.8/23.0	64.1/78.3	043	043	043	043	
			CRHEATER415A00	32.0	5	10	24.0/29.4	82.0/100.3	043	043	043	043	
			CRHEATER416A00	42.4	5	10	31.8/38.9	108.7/132.9	045	045	045	045	
		HIGH	CRHEATER411A00	10.4	5	10	7.8/9.6	26.7/32.6	042	042	042	042	
			CRHEATER412A00	16.0	5	10	12.0/14.7	41.0/50.1	042	043	043	043	
			CRHEATER414A00	25.0	5	10	18.8/23.0	64.1/78.3	043	043	043	043	
			CRHEATER415A00	32.0	5	10	24.0/29.4	82.0/100.3	043	043	043	043	
			CRHEATER416A00	42.4	5	10	31.8/38.9	108.7/132.9	045	045	045	045	
		460-3-60	STD/ MED	CRHEATER420A00	15.0	5	10	13.8	47.0	042	042	042	042
				CRHEATER421A00	25.0	5	10	23.0	78.3	042	042	042	042
	CRHEATER422A00			33.0	5	10	30.3	103.4	042	042	042	042	
	CRHEATER423A00			41.7	5	10	38.3	130.7	044	044	044	044	
	CRHEATER420A00			15.0	5	10	13.8	47.0	042	042	042	042	
	HIGH		CRHEATER421A00	25.0	5	10	23.0	78.3	042	042	042	042	
			CRHEATER422A00	33.0	5	10	30.3	103.4	042	042	042	042	
			CRHEATER423A00	41.7	5	10	38.3	130.7	044	044	044	044	
			CRHEATER425A00	18.0	5	—	16.5	56.4	042	042	042	042	
			CRHEATER427A00	36.0	5	—	33.1	112.8	042	042	042	042	
	575-3-60		STD/ MED	CRHEATER425A00	18.0	5	—	16.5	56.4	042	042	042	042
				CRHEATER427A00	36.0	5	—	33.1	112.8	042	042	042	042
		HIGH	CRHEATER425A00	18.0	5	—	16.5	56.4	042	042	042	042	
				CRHEATER427A00	36.0	5	—	33.1	112.8	042	042	042	042

NOTE(S):

- a. High SCCR (Short Circuit Current Rating) is not available on units with Hot Gas Re-Heat system, powered convenience outlet, phase loss monitor, non-fused disconnect, or 575-v.

Electrical data (cont)

RAF090 Electric Heat Data — Without Non-fused Disconnect (cont)

RAF UNIT SIZE	NOM. V-Ph-Hz	IFM TYPE	ELECTRIC HEATER PART NUMBER	NOM (kW)	STD SCCR kA	HIGH SCCR kA ^a	APPLICATION (kW)	APPLICATION OUTPUT (MBH)	HSCCR SINGLE POINT OR JUNCTION KIT PART NUMBER CRSINGLEXXXA00				
									NO C.O. OR UNPOWERED C.O.		WITH PWRD C.O.		
									NO P.E.	WITH P.E. (pwrd fr/unit)	NO P.E	WITH P.E. (pwrd fr/unit)	
RAF090	208/230-3-60	STD/MED	CRHEATER411A00	10.4	5	10	7.8/9.6	26.7/32.6	064	064	064	064	
			CRHEATER412A00	16.0	5	10	12.0/14.7	41.0/50.1	064	064	064	064	
			CRHEATER414A00	25.0	5	10	18.8/23.0	64.1/78.3	065	065	065	065	
			CRHEATER415A00	32.0	5	10	24.0/29.4	82.0/100.3	065	065	065	065	
			CRHEATER416A00	42.4	5	10	31.8/38.9	108.7/132.9	066	066	066	066	
		HIGH	CRHEATER411A00	10.4	5	10	7.8/9.6	26.7/32.6	064	064	064	064	
			CRHEATER412A00	16.0	5	10	12.0/14.7	41.0/50.1	064	064	064	064	
			CRHEATER414A00	25.0	5	10	18.8/23.0	64.1/78.3	065	065	065	065	
			CRHEATER415A00	32.0	5	10	24.0/29.4	82.0/100.3	065	065	065	065	
			CRHEATER416A00	42.4	5	10	31.8/38.9	108.7/132.9	066	066	066	066	
		460-3-60	STD/MED	CRHEATER420A00	15.0	5	10	13.8	47.0	064	064	064	064
				CRHEATER421A00	25.0	5	10	23.0	78.3	065	065	065	065
	CRHEATER422A00			33.0	5	10	30.3	103.4	065	065	065	065	
	CRHEATER423A00			41.7	5	10	38.3	130.7	065	065	065	065	
	HIGH		CRHEATER420A00	15.0	5	10	13.8	47.0	064	064	064	064	
			CRHEATER421A00	25.0	5	10	23.0	78.3	065	065	065	065	
			CRHEATER422A00	33.0	5	10	30.3	103.4	065	065	065	065	
			CRHEATER423A00	41.7	5	10	38.3	130.7	065	065	065	065	
	575-3-60	STD/MED	CRHEATER425A00	18.0	5	—	16.5	56.4	064	064	064	064	
			CRHEATER427A00	36.0	5	—	33.1	112.8	065	065	065	065	
		HIGH	CRHEATER425A00	18.0	5	—	16.5	56.4	064	064	064	064	
CRHEATER427A00			36.0	5	—	33.1	112.8	065	065	065	065		

NOTE(S):

- a. High SCCR (Short Circuit Current Rating) is not available on units with Hot Gas Re-Heat system, powered convenience outlet, phase loss monitor, non-fused disconnect, or 575-v.

Electrical data (cont)

RAF090 Electric Heat Data — With Non-fused Disconnect

RAF UNIT SIZE	NOM. V-Ph-Hz	IFM TYPE	ELECTRIC HEATER PART NUMBER	NOM (kW)	STD SCCR kA	APPLICATION (kW)	APPLICATION OUTPUT (MBH)	SINGLE POINT OR JUNCTION KIT PART NUMBER CRSINGLEXXXXA00				
								NO C.O. OR UNPOWERED C.O.		WITH PWRD C.O.		
								NO P.E.	WITH P.E. (pwrd fr/unit)	NO P.E.	WITH P.E. (pwrd fr/unit)	
RAF090	208/230-3-60	STD/ MED	CRHEATER411A00	10.4	5	7.8/9.6	26.7/32.6	042	042	042	042	
			CRHEATER412A00	16.0	5	12.0/14.7	41.0/50.1	042	043	043	043	
			CRHEATER414A00	25.0	5	18.8/23.0	64.1/78.3	043	043	043	043	
			CRHEATER415A00	32.0	5	24.0/29.4	82.0/100.3	043	043	043	043	
			CRHEATER416A00	42.4	5	31.8/38.9	108.7/132.9	045	045	045	045	
		HIGH	CRHEATER411A00	10.4	5	7.8/9.6	26.7/32.6	042	042	042	042	
			CRHEATER412A00	16.0	5	12.0/14.7	41.0/50.1	042	043	043	043	
			CRHEATER414A00	25.0	5	18.8/23.0	64.1/78.3	043	043	043	043	
			CRHEATER415A00	32.0	5	24.0/29.4	82.0/100.3	043	043	043	043	
			CRHEATER416A00	42.4	5	31.8/38.9	108.7/132.9	045	045	045	045	
		460-3-60	STD/ MED	CRHEATER420A00	15.0	5	13.8	47.0	042	042	042	042
				CRHEATER421A00	25.0	5	23.0	78.3	042	042	042	042
	CRHEATER422A00			33.0	5	30.3	103.4	042	042	042	042	
	CRHEATER423A00			41.7	5	38.3	130.7	044	044	044	044	
	HIGH		CRHEATER420A00	15.0	5	13.8	47.0	042	042	042	042	
			CRHEATER421A00	25.0	5	23.0	78.3	042	042	042	042	
			CRHEATER422A00	33.0	5	30.3	103.4	042	042	042	042	
			CRHEATER423A00	41.7	5	38.3	130.7	044	044	044	044	
			CRHEATER425A00	18.0	5	16.5	56.4	042	042	042	042	
	575-3-60	STD/ MED	CRHEATER425A00	18.0	5	16.5	56.4	042	042	042	042	
			CRHEATER427A00	36.0	5	33.1	112.8	042	042	042	042	
		HIGH	CRHEATER425A00	18.0	5	16.5	56.4	042	042	042	042	
			CRHEATER427A00	36.0	5	33.1	112.8	042	042	042	042	

Electrical data (cont)

RAF102 Electric Heat Data — Without Non-fused Disconnect

RAF UNIT SIZE	NOM. V-Ph-Hz	IFM TYPE	ELECTRIC HEATER PART NUMBER	NOM (kW)	STD SCCR kA	HIGH SCCR kA ^a	APPLICATION (kW)	APPLICATION OUTPUT (MBH)	SINGLE POINT OR JUNCTION KIT PART NUMBER CRSINGLEXXXA00			
									NO C.O. OR UNPOWERED C.O.		WITH PWRD C.O.	
									NO P.E.	WITH P.E. (pwrd fr/unit)	NO P.E	WITH P.E. (pwrd fr/unit)
RAF102	208/230-3-60	STD/MED	CRHEATER411A00	10.4	5	10	7.8/9.6	26.7/32.6	047	047	047	047
			CRHEATER412A00	16.0	5	10	12.0/14.7	41.0/50.1	047	049	049	049
			CRHEATER414A00	25.0	5	10	18.8/23.0	64.1/78.3	049	049	049	049
			CRHEATER415A00	32.0	5	10	24.0/29.4	82.0/100.3	049	049	049	049
			CRHEATER416A00	42.4	5	10	31.8/38.9	108.7/132.9	051	051	051	051
		HIGH	CRHEATER411A00	10.4	5	10	7.8/9.6	26.7/32.6	047	047	047	047
			CRHEATER412A00	16.0	5	10	12.0/14.7	41.0/50.1	047	049	049	049
			CRHEATER414A00	25.0	5	10	18.8/23.0	64.1/78.3	049	049	049	049
			CRHEATER415A00	32.0	5	10	24.0/29.4	82.0/100.3	049	049	049	049
			CRHEATER416A00	42.4	5	10	31.8/38.9	108.7/132.9	051	051	051	051
	460-3-60	STD/MED	CRHEATER420A00	15.0	5	10	13.8	47.0	047	047	047	047
			CRHEATER421A00	25.0	5	10	23.0	78.3	047	047	047	047
			CRHEATER422A00	33.0	5	10	30.3	103.4	047	047	047	047
			CRHEATER423A00	41.7	5	10	38.3	130.7	050	050	050	050
		HIGH	CRHEATER420A00	15.0	5	10	13.8	47.0	047	047	047	047
			CRHEATER421A00	25.0	5	10	23.0	78.3	047	047	047	047
			CRHEATER422A00	33.0	5	10	30.3	103.4	047	047	047	047
			CRHEATER423A00	41.7	5	10	38.3	130.7	050	050	050	050
	575-3-60	STD/MED	CRHEATER425A00	18.0	5	—	16.5	56.4	047	047	047	047
			CRHEATER427A00	36.0	5	—	33.1	112.8	047	047	047	047
HIGH		CRHEATER425A00	18.0	5	—	16.5	56.4	047	047	047	047	
		CRHEATER427A00	36.0	5	—	33.1	112.8	047	047	047	047	

NOTE(S):

- a. High SCCR (Short Circuit Current Rating) is not available on units with Hot Gas Re-Heat system, powered convenience outlet, phase loss monitor, non-fused disconnect, or 575-v.

Electrical data (cont)

RAF102 Electric Heat Data — Without Non-fused Disconnect (cont)

RAF UNIT SIZE	NOM. V-Ph-Hz	IFM TYPE	ELECTRIC HEATER PART NUMBER	NOM (kW)	STD SCCR kA	HIGH SCCR kA ^a	APPLICATION (kW)	APPLICATION OUTPUT (MBH)	HSCCR SINGLE POINT OR JUNCTION KIT PART NUMBER CRSINGLEXXXA00				
									NO C.O. OR UNPOWERED C.O.		WITH PWRD C.O.		
									NO P.E.	WITH P.E. (pwrd fr/unit)	NO P.E	WITH P.E. (pwrd fr/unit)	
RAF102	208/230-3-60	STD/MED	CRHEATER411A00	10.4	5	10	7.8/9.6	26.7/32.6	067	067	067	067	
			CRHEATER412A00	16.0	5	10	12.0/14.7	41.0/50.1	067	067	067	067	
			CRHEATER414A00	25.0	5	10	18.8/23.0	64.1/78.3	068	068	068	068	
			CRHEATER415A00	32.0	5	10	24.0/29.4	82.0/100.3	068	068	068	068	
			CRHEATER416A00	42.4	5	10	31.8/38.9	108.7/132.9	069	069	069	069	
		HIGH	CRHEATER411A00	10.4	5	10	7.8/9.6	26.7/32.6	067	067	067	067	
			CRHEATER412A00	16.0	5	10	12.0/14.7	41.0/50.1	067	067	067	067	
			CRHEATER414A00	25.0	5	10	18.8/23.0	64.1/78.3	068	068	068	068	
			CRHEATER415A00	32.0	5	10	24.0/29.4	82.0/100.3	068	068	068	068	
			CRHEATER416A00	42.4	5	10	31.8/38.9	108.7/132.9	069	069	069	069	
		460-3-60	STD/MED	CRHEATER420A00	15.0	5	10	13.8	47.0	067	067	067	067
				CRHEATER421A00	25.0	5	10	23.0	78.3	068	068	068	068
	CRHEATER422A00			33.0	5	10	30.3	103.4	068	068	068	068	
	CRHEATER423A00			41.7	5	10	38.3	130.7	068	068	068	068	
	HIGH		CRHEATER420A00	15.0	5	10	13.8	47.0	067	067	067	067	
			CRHEATER421A00	25.0	5	10	23.0	78.3	068	068	068	068	
			CRHEATER422A00	33.0	5	10	30.3	103.4	068	068	068	068	
			CRHEATER423A00	41.7	5	10	38.3	130.7	068	068	068	068	
	575-3-60	STD/MED	CRHEATER425A00	18.0	5	—	16.5	56.4	067	067	067	067	
			CRHEATER427A00	36.0	5	—	33.1	112.8	068	068	068	068	
		HIGH	CRHEATER425A00	18.0	5	—	16.5	56.4	067	067	067	067	
			CRHEATER427A00	36.0	5	—	33.1	112.8	068	068	068	068	

NOTE(S):

- a. High SCCR (Short Circuit Current Rating) is not available on units with Hot Gas Re-Heat system, powered convenience outlet, phase loss monitor, non-fused disconnect, or 575-v.

Electrical data (cont)

RAF102 Electric Heat Data — With Non-fused Disconnect

RAF UNIT SIZE	NOM. V-Ph-Hz	IFM TYPE	ELECTRIC HEATER PART NUMBER	NOM (kW)	STD SCCR kA	APPLICATION (kW)	APPLICATION OUTPUT (MBH)	SINGLE POINT OR JUNCTION KIT PART NUMBER CRSINGLEXXXXA00			
								NO C.O. OR UNPOWERED C.O.		WITH PWRD C.O.	
								NO P.E.	WITH P.E. (pwrd fr/unit)	NO P.E.	WITH P.E. (pwrd fr/unit)
RAF102	208/230-3-60	STD/ MED	CRHEATER411A00	10.4	5	7.8/9.6	26.7/32.6	047	047	047	047
			CRHEATER412A00	16.0	5	12.0/14.7	41.0/50.1	047	049	049	049
			CRHEATER414A00	25.0	5	18.8/23.0	64.1/78.3	049	049	049	049
			CRHEATER415A00	32.0	5	24.0/29.4	82.0/100.3	049	049	049	049
			CRHEATER416A00	42.4	5	31.8/38.9	108.7/132.9	051	051	051	051
		HIGH	CRHEATER411A00	10.4	5	7.8/9.6	26.7/32.6	047	047	047	047
			CRHEATER412A00	16.0	5	12.0/14.7	41.0/50.1	047	049	049	049
			CRHEATER414A00	25.0	5	18.8/23.0	64.1/78.3	049	049	049	049
			CRHEATER415A00	32.0	5	24.0/29.4	82.0/100.3	049	049	049	049
			CRHEATER416A00	42.4	5	31.8/38.9	108.7/132.9	051	051	051	051
	460-3-60	STD/ MED	CRHEATER420A00	15.0	5	13.8	47.0	047	047	047	047
			CRHEATER421A00	25.0	5	23.0	78.3	047	047	047	047
			CRHEATER422A00	33.0	5	30.3	103.4	047	047	047	047
			CRHEATER423A00	41.7	5	38.3	130.7	050	050	050	050
		HIGH	CRHEATER420A00	15.0	5	13.8	47.0	047	047	047	047
			CRHEATER421A00	25.0	5	23.0	78.3	047	047	047	047
			CRHEATER422A00	33.0	5	30.3	103.4	047	047	047	047
			CRHEATER423A00	41.7	5	38.3	130.7	050	050	050	050
	575-3-60	STD/ MED	CRHEATER425A00	18.0	5	16.5	56.4	047	047	047	047
			CRHEATER427A00	36.0	5	33.1	112.8	047	047	047	047
		HIGH	CRHEATER425A00	18.0	5	16.5	56.4	047	047	047	047
			CRHEATER427A00	36.0	5	33.1	112.8	047	047	047	047

Electrical data (cont)

RAF120 Electric Heat Data — Without Non-fused Disconnect

RAF UNIT SIZE	NOM. V-Ph-Hz	IFM TYPE	ELECTRIC HEATER PART NUMBER	NOM (kW)	STD SCCR kA	HIGH SCCR kA ^a	APPLICATION (kW)	APPLICATION OUTPUT (MBH)	SINGLE POINT OR JUNCTION KIT PART NUMBER CRSINGLEXXA00				
									NO C.O. OR UNPOWERED C.O.		WITH PWRD C.O.		
									NO P.E.	WITH P.E. (pwrd fr/unit)	NO P.E	WITH P.E. (pwrd fr/unit)	
RAF120	208/230-3-60	STD/MED	CRHEATER411A00	10.4	5	10	7.8/9.6	26.7/32.6	047	047	049	049	
			CRHEATER412A00	16.0	5	10	12.0/14.7	41.0/50.1	047	049	049	049	
			CRHEATER415A00	32.0	5	10	24.0/29.4	82.0/100.3	049	049	049	049	
			CRHEATER416A00	42.4	5	10	31.8/38.9	108.7/132.9	051	051	051	051	
			CRHEATER417A00	50.0	5	10	37.6/45.9	128.1/156.7	051	051	051	051	
		HIGH	CRHEATER411A00	10.4	5	10	7.8/9.6	26.7/32.6	049	049	049	049	
			CRHEATER412A00	16.0	5	10	12.0/14.7	41.0/50.1	049	049	049	049	
			CRHEATER415A00	32.0	5	10	24.0/29.4	82.0/100.3	049	049	049	049	
			CRHEATER416A00	42.4	5	10	31.8/38.9	108.7/132.9	051	051	051	051	
			CRHEATER417A00	50.0	5	10	37.6/45.9	128.1/156.7	051	051	051	051	
		460-3-60	STD/MED	CRHEATER420A00	15.0	5	10	13.8	47.0	047	047	047	047
				CRHEATER422A00	33.0	5	10	30.3	103.4	047	047	047	047
	CRHEATER423A00			41.7	5	10	38.3	130.7	050	050	050	050	
	CRHEATER424A00			50.0	5	10	45.9	156.7	050	050	050	050	
	HIGH		CRHEATER420A00	15.0	5	10	13.8	47.0	047	047	047	047	
			CRHEATER422A00	33.0	5	10	30.3	103.4	047	047	047	050	
			CRHEATER423A00	41.7	5	10	38.3	130.7	050	050	050	050	
			CRHEATER424A00	50.0	5	10	45.9	156.7	050	050	050	050	
	575-3-60	STD/MED	CRHEATER425A00	18.0	5	—	16.5	56.4	047	047	047	047	
			CRHEATER427A00	36.0	5	—	33.1	112.8	047	047	047	047	
			CRHEATER428A00	50.0	5	—	45.9	156.7	047	047	047	047	
		HIGH	CRHEATER425A00	18.0	5	—	16.5	56.4	047	047	047	047	
			CRHEATER427A00	36.0	5	—	33.1	112.8	047	047	047	047	
			CRHEATER428A00	50.0	5	—	45.9	156.7	047	047	047	050	

NOTE(S):

- a. High SCCR (Short Circuit Current Rating) is not available on units with Hot Gas Re-Heat system, powered convenience outlet, phase loss monitor, non-fused disconnect, or 575-v.

Electrical data (cont)

RAF120 Electric Heat Data — Without Non-fused Disconnect (cont)

RAF UNIT SIZE	NOM. V-Ph-Hz	IFM TYPE	ELECTRIC HEATER PART NUMBER	NOM (kW)	STD SCCR kA	HIGH SCCR kA ^a	APPLICATION (kW)	APPLICATION OUTPUT (MBH)	HSCCR SINGLE POINT OR JUNCTION KIT PART NUMBER CRSINGLEXXXA00				
									NO C.O. OR UNPOWERED C.O.		WITH PWRD C.O.		
									NO P.E.	WITH P.E. (pwrd fr/unit)	NO P.E	WITH P.E. (pwrd fr/unit)	
RAF120	208/230-3-60	STD/MED	CRHEATER411A00	10.4	5	10	7.8/9.6	26.7/32.6	067	067	067	067	
			CRHEATER412A00	16.0	5	10	12.0/14.7	41.0/50.1	067	067	067	067	
			CRHEATER415A00	32.0	5	10	24.0/29.4	82.0/100.3	068	068	068	068	
			CRHEATER416A00	42.4	5	10	31.8/38.9	108.7/132.9	069	069	069	069	
			CRHEATER417A00	50.0	5	10	37.6/45.9	128.1/156.7	069	069	069	069	
		HIGH	CRHEATER411A00	10.4	5	10	7.8/9.6	26.7/32.6	067	067	067	067	
			CRHEATER412A00	16.0	5	10	12.0/14.7	41.0/50.1	067	067	067	067	
			CRHEATER415A00	32.0	5	10	24.0/29.4	82.0/100.3	068	068	068	068	
			CRHEATER416A00	42.4	5	10	31.8/38.9	108.7/132.9	069	069	069	069	
			CRHEATER417A00	50.0	5	10	37.6/45.9	128.1/156.7	069	069	069	069	
		460-3-60	STD/MED	CRHEATER420A00	15.0	5	10	13.8	47.0	067	067	067	067
				CRHEATER422A00	33.0	5	10	30.3	103.4	068	068	068	068
	CRHEATER423A00			41.7	5	10	38.3	130.7	068	068	068	068	
	CRHEATER424A00			50.0	5	10	45.9	156.7	068	068	068	068	
	CRHEATER420A00			15.0	5	10	13.8	47.0	067	067	067	067	
	HIGH		CRHEATER422A00	33.0	5	10	30.3	103.4	068	068	068	068	
			CRHEATER423A00	41.7	5	10	38.3	130.7	068	068	068	068	
			CRHEATER424A00	50.0	5	10	45.9	156.7	068	068	068	068	
			CRHEATER425A00	18.0	5	—	16.5	56.4	067	067	067	067	
			CRHEATER427A00	36.0	5	—	33.1	112.8	068	068	068	068	
	575-3-60		STD/MED	CRHEATER428A00	50.0	5	—	45.9	156.7	068	068	068	068
				CRHEATER425A00	18.0	5	—	16.5	56.4	067	067	067	067
		CRHEATER427A00		36.0	5	—	33.1	112.8	068	068	068	068	
		HIGH	CRHEATER428A00	50.0	5	—	45.9	156.7	068	068	068	068	
CRHEATER428A00			50.0	5	—	45.9	156.7	068	068	068	068		

NOTE(S):

- a. High SCCR (Short Circuit Current Rating) is not available on units with Hot Gas Re-Heat system, powered convenience outlet, phase loss monitor, non-fused disconnect, or 575-v.

Electrical data (cont)

RAF120 Electric Heat Data — With Non-fused Disconnect

RAF UNIT SIZE	NOM. V-Ph-Hz	IFM TYPE	ELECTRIC HEATER PART NUMBER	NOM (kW)	STD SCCR kA	APPLICATION (kW)	APPLICATION OUTPUT (MBH)	SINGLE POINT OR JUNCTION KIT PART NUMBER CRSINGLEXXXA00				
								NO C.O. OR UNPOWERED C.O.		WITH PWRD C.O.		
								NO P.E.	WITH P.E. (pwrd fr/unit)	NO P.E.	WITH P.E. (pwrd fr/unit)	
RAF120	208/230-3-60	STD/ MED	CRHEATER411A00	10.4	5	7.8/9.6	26.7/32.6	047	047	049	049	
			CRHEATER412A00	16.0	5	12.0/14.7	41.0/50.1	047	049	049	049	
			CRHEATER415A00	32.0	5	24.0/29.4	82.0/100.3	049	049	049	049	
			CRHEATER416A00	42.4	5	31.8/38.9	108.7/132.9	051	051	051	051	
			CRHEATER417A00	50.0	5	37.6/45.9	128.1/156.7	051	051	051	051	
		HIGH	CRHEATER411A00	10.4	5	7.8/9.6	26.7/32.6	049	049	049	049	
			CRHEATER412A00	16.0	5	12.0/14.7	41.0/50.1	049	049	049	049	
			CRHEATER415A00	32.0	5	24.0/29.4	82.0/100.3	049	049	049	049	
			CRHEATER416A00	42.4	5	31.8/38.9	108.7/132.9	051	051	051	051	
			CRHEATER417A00	50.0	5	37.6/45.9	128.1/156.7	051	051	051	051	
		460-3-60	STD/ MED	CRHEATER420A00	15.0	5	13.8	47.0	047	047	047	047
				CRHEATER422A00	33.0	5	30.3	103.4	047	047	047	047
	CRHEATER423A00			41.7	5	38.3	130.7	050	050	050	050	
	CRHEATER424A00			50.0	5	45.9	156.7	050	050	050	050	
	HIGH		CRHEATER420A00	15.0	5	13.8	47.0	047	047	047	047	
			CRHEATER422A00	33.0	5	30.3	103.4	047	047	047	050	
			CRHEATER423A00	41.7	5	38.3	130.7	050	050	050	050	
			CRHEATER424A00	50.0	5	45.9	156.7	050	050	050	050	
	575-3-60		STD/ MED	CRHEATER425A00	18.0	5	16.5	56.4	047	047	047	047
				CRHEATER427A00	36.0	5	33.1	112.8	047	047	047	047
			HIGH	CRHEATER428A00	50.0	5	45.9	156.7	047	047	047	047
				CRHEATER425A00	18.0	5	16.5	56.4	047	047	047	047
				CRHEATER427A00	36.0	5	33.1	112.8	047	047	047	047
				CRHEATER428A00	50.0	5	45.9	156.7	047	047	047	050

Electrical data (cont)

RAF150 Electric Heat Data — Without Non-fused Disconnect

RAF UNIT SIZE	NOM. V-Ph-Hz	IFM TYPE	ELECTRIC HEATER PART NUMBER	NOM (kW)	STD SCCR kA	HIGH SCCR kA ^a	APPLICATION (kW)	APPLICATION OUTPUT (MBH)	SINGLE POINT OR JUNCTION KIT PART NUMBER CRSINGLEXXXA00			
									NO C.O. OR UNPOWERED C.O.		WITH PWRD C.O.	
									NO P.E.	WITH P.E. (pwrd fr/unit)	NO P.E	WITH P.E. (pwrd fr/unit)
RAF150	208/230-3-60	STD/MED	CRHEATER411A00	10.4	5	—	7.8/9.6	26.7/32.6	049	049	049	049
			CRHEATER412A00	16.0	5	—	12.0/14.7	41.0/50.1	049	049	049	049
			CRHEATER415A00	32.0	5	—	24.0/29.4	82.0/100.3	049	049	049	049
			CRHEATER416A00	42.4	5	—	31.8/38.9	108.7/132.9	051	051	051	051
			CRHEATER417A00	50.0	5	—	37.6/45.9	128.1/156.7	051	051	051	051
			CRHEATER411A00	10.4	5	—	7.8/9.6	26.7/32.6	049	049	049	049
		HIGH	CRHEATER412A00	16.0	5	—	12.0/14.7	41.0/50.1	049	049	049	049
			CRHEATER415A00	32.0	5	—	24.0/29.4	82.0/100.3	049	049	049	049
			CRHEATER416A00	42.4	5	—	31.8/38.9	108.7/132.9	051	051	051	051
			CRHEATER417A00	50.0	5	—	37.6/45.9	128.1/156.7	051	051	051	051
			CRHEATER420A00	15.0	5	—	13.8	47.0	047	047	047	047
			CRHEATER422A00	33.0	5	—	30.3	103.4	047	047	047	047
	460-3-60	STD/MED	CRHEATER423A00	41.7	5	—	38.3	130.7	050	050	050	050
			CRHEATER424A00	50.0	5	—	45.9	156.7	050	050	050	050
			CRHEATER420A00	15.0	5	—	13.8	47.0	047	047	047	047
		HIGH	CRHEATER422A00	33.0	5	—	30.3	103.4	047	047	047	050
			CRHEATER423A00	41.7	5	—	38.3	130.7	050	050	050	050
			CRHEATER424A00	50.0	5	—	45.9	156.7	050	050	050	050
	575-3-60	STD/MED	CRHEATER425A00	18.0	5	—	16.5	56.4	047	047	047	047
			CRHEATER427A00	36.0	5	—	33.1	112.8	047	047	047	047
			CRHEATER428A00	50.0	5	—	45.9	156.7	047	047	047	047
		HIGH	CRHEATER425A00	18.0	5	—	16.5	56.4	047	047	047	047
			CRHEATER427A00	36.0	5	—	33.1	112.8	047	047	047	047
			CRHEATER428A00	50.0	5	—	45.9	156.7	047	047	047	050

NOTE(S):

- a. High SCCR (Short Circuit Current Rating) is not available on units with Hot Gas Re-Heat system, powered convenience outlet, phase loss monitor, non-fused disconnect, or 575-v.

Electrical data (cont)

RAF150 Electric Heat Data — Without Non-fused Disconnect (cont)

RAF UNIT SIZE	NOM. V-Ph-Hz	IFM TYPE	ELECTRIC HEATER PART NUMBER	NOM (kW)	STD SCCR kA	HIGH SCCR kA ^a	APPLICATION (kW)	APPLICATION OUTPUT (MBH)	HSCCR SINGLE POINT OR JUNCTION KIT PART NUMBER CRSINGLEXXXA00			
									NO C.O. OR UNPOWERED C.O.		WITH PWRD C.O.	
									NO P.E.	WITH P.E. (pwrd fr/unit)	NO P.E	WITH P.E. (pwrd fr/unit)
RAF150	208/230-3-60	STD/MED	CRHEATER411A00	10.4	5	—	7.8/9.6	26.7/32.6	067	067	067	067
			CRHEATER412A00	16.0	5	—	12.0/14.7	41.0/50.1	067	067	067	067
			CRHEATER415A00	32.0	5	—	24.0/29.4	82.0/100.3	068	068	068	068
			CRHEATER416A00	42.4	5	—	31.8/38.9	108.7/132.9	069	069	069	069
			CRHEATER417A00	50.0	5	—	37.6/45.9	128.1/156.7	069	069	069	069
		HIGH	CRHEATER411A00	10.4	5	—	7.8/9.6	26.7/32.6	067	067	067	067
			CRHEATER412A00	16.0	5	—	12.0/14.7	41.0/50.1	067	067	067	067
			CRHEATER415A00	32.0	5	—	24.0/29.4	82.0/100.3	068	068	068	068
			CRHEATER416A00	42.4	5	—	31.8/38.9	108.7/132.9	069	069	069	069
			CRHEATER417A00	50.0	5	—	37.6/45.9	128.1/156.7	069	069	069	069
	460-3-60	STD/MED	CRHEATER420A00	15.0	5	—	13.8	47.0	067	067	067	067
			CRHEATER422A00	33.0	5	—	30.3	103.4	068	068	068	068
			CRHEATER423A00	41.7	5	—	38.3	130.7	068	068	068	068
			CRHEATER424A00	50.0	5	—	45.9	156.7	068	068	068	068
		HIGH	CRHEATER420A00	15.0	5	—	13.8	47.0	067	067	067	067
			CRHEATER422A00	33.0	5	—	30.3	103.4	068	068	068	068
			CRHEATER423A00	41.7	5	—	38.3	130.7	068	068	068	068
			CRHEATER424A00	50.0	5	—	45.9	156.7	068	068	068	068
	575-3-60	STD/MED	CRHEATER425A00	18.0	5	—	16.5	56.4	067	067	067	067
			CRHEATER427A00	36.0	5	—	33.1	112.8	068	068	068	068
			CRHEATER428A00	50.0	5	—	45.9	156.7	068	068	068	068
		HIGH	CRHEATER425A00	18.0	5	—	16.5	56.4	067	067	067	067
			CRHEATER427A00	36.0	5	—	33.1	112.8	068	068	068	068
			CRHEATER428A00	50.0	5	—	45.9	156.7	068	068	068	068

NOTE(S):

- a. High SCCR (Short Circuit Current Rating) is not available on units with Hot Gas Re-Heat system, powered convenience outlet, phase loss monitor, non-fused disconnect, or 575-v.

Electrical data (cont)

RAF150 Electric Heat Data — With Non-fused Disconnect

RAF UNIT SIZE	NOM. V-Ph-Hz	IFM TYPE	ELECTRIC HEATER PART NUMBER	NOM (kW)	STD SCCR kA	APPLICATION (kW)	APPLICATION OUTPUT (MBH)	SINGLE POINT OR JUNCTION KIT PART NUMBER CRSINGLEXXXXA00				
								NO C.O. OR UNPOWERED C.O.		WITH PWRD C.O.		
								NO P.E.	WITH P.E. (pwrd fr/unit)	NO P.E.	WITH P.E. (pwrd fr/unit)	
RAF150	208/230-3-60	STD/ MED	CRHEATER411A00	10.4	5	7.8/9.6	26.7/32.6	049	049	049	049	
			CRHEATER412A00	16.0	5	12.0/14.7	41.0/50.1	049	049	049	049	
			CRHEATER415A00	32.0	5	24.0/29.4	82.0/100.3	049	049	049	049	
			CRHEATER416A00	42.4	5	31.8/38.9	108.7/132.9	051	051	051	051	
			CRHEATER417A00	50.0	5	37.6/45.9	128.1/156.7	051	051	051	051	
		HIGH	CRHEATER411A00	10.4	5	7.8/9.6	26.7/32.6	049	049	049	049	
			CRHEATER412A00	16.0	5	12.0/14.7	41.0/50.1	049	049	049	049	
			CRHEATER415A00	32.0	5	24.0/29.4	82.0/100.3	049	049	049	049	
			CRHEATER416A00	42.4	5	31.8/38.9	108.7/132.9	051	051	051	051	
			CRHEATER417A00	50.0	5	37.6/45.9	128.1/156.7	051	051	051	051	
		460-3-60	STD/ MED	CRHEATER420A00	15.0	5	13.8	47.0	047	047	047	047
				CRHEATER422A00	33.0	5	30.3	103.4	047	047	047	047
	CRHEATER423A00			41.7	5	38.3	130.7	050	050	050	050	
	CRHEATER424A00			50.0	5	45.9	156.7	050	050	050	050	
	HIGH		CRHEATER420A00	15.0	5	13.8	47.0	047	047	047	047	
			CRHEATER422A00	33.0	5	30.3	103.4	047	047	047	050	
			CRHEATER423A00	41.7	5	38.3	130.7	050	050	050	050	
			CRHEATER424A00	50.0	5	45.9	156.7	050	050	050	050	
			CRHEATER425A00	18.0	5	16.5	56.4	047	047	047	047	
	575-3-60	STD/ MED	CRHEATER427A00	36.0	5	33.1	112.8	047	047	047	047	
			CRHEATER428A00	50.0	5	45.9	156.7	047	047	047	047	
			CRHEATER425A00	18.0	5	16.5	56.4	047	047	047	047	
		HIGH	CRHEATER427A00	36.0	5	33.1	112.8	047	047	047	047	
			CRHEATER428A00	50.0	5	45.9	156.7	047	047	047	050	

Electrical data (cont)

RAF180 Electric Heat Data — Without Non-fused Disconnect

RAF UNIT SIZE	NOM. V-PH-Hz	IFM TYPE	ELECTRIC HEATER PART NUMBER	NOM (kW)	STD SCCR kA	HIGH SCCR kA ^a	APPLICATION (kW)	APPLICATION OUTPUT (MBH)	SINGLE POINT OR JUNCTION KIT PART NUMBER CRSINGLEXXXA00				
									NO C.O. OR UNPOWERED C.O.		WITH PWRD C.O.		
									NO P.E.	WITH P.E. (pwrd fr/unit)	NO P.E.	WITH P.E. (pwrd fr/unit)	
RAF180	208/230-3-60	STD/MED	CRHEATER412A00	16.0	5	10	12.0/14.7	41.0/50.1	049	049	049	049	
			CRHEATER414A00	25.0	5	10	18.8/23.0	64.1/78.3	049	049	049	049	
			CRHEATER415A00	32.0	5	10	24.0/29.4	82.0/100.3	049	049	049	049	
			CRHEATER416A00	42.4	5	10	31.8/38.9	108.7/132.9	051	051	051	051	
			CRHEATER417A00	50.0	5	10	37.6/45.9	128.1/156.7	051	051	051	051	
		CRHEATER451A00	67.0	5	10	50.3/61.5	171.7/210.0	053	053	053	053		
		HIGH	CRHEATER412A00	16.0	5	10	12.0/14.7	41.0/50.1	049	049	049	049	
			CRHEATER414A00	25.0	5	10	18.8/23.0	64.1/78.3	049	049	049	049	
			CRHEATER415A00	32.0	5	10	24.0/29.4	82.0/100.3	049	049	049	049	
			CRHEATER416A00	42.4	5	10	31.8/38.9	108.7/132.9	051	051	051	051	
			CRHEATER417A00	50.0	5	10	37.6/45.9	128.1/156.7	051	051	051	051	
		CRHEATER451A00	67.0	5	10	50.3/61.5	171.7/210.0	053	053	053	053		
		460-3-60	STD/MED	CRHEATER420A00	15.0	5	10	13.8	47.0	—	—	—	—
				CRHEATER421A00	25.0	5	10	23.0	78.3	047	047	047	047
	CRHEATER422A00			33.0	5	10	30.3	103.4	047	047	047	047	
	CRHEATER423A00			41.7	5	10	38.3	130.7	050	050	050	050	
	CRHEATER424A00			50.0	5	10	45.9	156.7	050	050	050	050	
	CRHEATER452A00			67.0	5	10	61.5	210.0	052	052	052	052	
	HIGH		CRHEATER420A00	15.0	5	10	13.8	47.0	—	—	—	—	
			CRHEATER421A00	25.0	5	10	23.0	78.3	047	047	047	047	
			CRHEATER422A00	33.0	5	10	30.3	103.4	047	047	047	050	
			CRHEATER423A00	41.7	5	10	38.3	130.7	050	050	050	050	
			CRHEATER424A00	50.0	5	10	45.9	156.7	050	050	050	050	
			CRHEATER452A00	67.0	5	10	61.5	210.0	052	052	052	052	
	575-3-60		STD/MED	CRHEATER425A00	18.0	5	—	16.5	56.4	—	—	—	—
				CRHEATER427A00	36.0	5	—	33.1	112.8	047	047	047	047
		CRHEATER428A00		50.0	5	—	45.9	156.7	047	047	047	047	
		CRHEATER453A00		67.0	5	—	61.5	210.0	052	052	052	052	
HIGH		CRHEATER425A00	18.0	5	—	16.5	56.4	—	—	—	—		
		CRHEATER427A00	36.0	5	—	33.1	112.8	047	047	047	047		
		CRHEATER428A00	50.0	5	—	45.9	156.7	047	047	047	050		
		CRHEATER453A00	67.0	5	—	61.5	210.0	052	052	052	052		

NOTE(S):

a. High SCCR (Short Circuit Current Rating) is not available on units with Hot Gas Re-Heat system, powered convenience outlet, phase loss monitor, non-fused disconnect, or 575-v.

Electrical data (cont)

RAF180 Electric Heat Data — Without Non-fused Disconnect (cont)

RAF UNIT SIZE	NOM. V-Ph-Hz	IFM TYPE	ELECTRIC HEATER PART NUMBER	NOM (kW)	STD SCCR kA	HIGH SCCR kA ^a	APPLICATION (kW)	APPLICATION OUTPUT (MBH)	HSCCR SINGLE POINT OR JUNCTION KIT PART NUMBER CRSINGLEXXXA00			
									NO C.O. OR UNPOWERED C.O.		WITH PWRD C.O.	
									NO P.E.	WITH P.E. (pwrd fr/unit)	NO P.E	WITH P.E. (pwrd fr/unit)
RAF180	208/230-3-60	STD/MED	CRHEATER412A00	16.0	5	10	12.0/14.7	41.0/50.1	067	067	067	067
			CRHEATER414A00	25.0	5	10	18.8/23.0	64.1/78.3	068	068	068	068
			CRHEATER415A00	32.0	5	10	24.0/29.4	82.0/100.3	068	068	068	068
			CRHEATER416A00	42.4	5	10	31.8/38.9	108.7/132.9	069	069	069	069
			CRHEATER417A00	50.0	5	10	37.6/45.9	128.1/156.7	069	069	069	069
		CRHEATER451A00	67.0	5	10	50.3/61.5	171.7/210.0	070	070	070	070	
		HIGH	CRHEATER412A00	16.0	5	10	12.0/14.7	41.0/50.1	067	067	067	067
			CRHEATER414A00	25.0	5	10	18.8/23.0	64.1/78.3	068	068	068	068
			CRHEATER415A00	32.0	5	10	24.0/29.4	82.0/100.3	068	068	068	068
			CRHEATER416A00	42.4	5	10	31.8/38.9	108.7/132.9	069	069	069	069
	CRHEATER417A00		50.0	5	10	37.6/45.9	128.1/156.7	069	069	069	069	
	460-3-60	STD/MED	CRHEATER420A00	15.0	5	10	13.8	47.0	067	067	067	067
			CRHEATER421A00	25.0	5	10	23.0	78.3	068	068	068	068
			CRHEATER422A00	33.0	5	10	30.3	103.4	068	068	068	068
			CRHEATER423A00	41.7	5	10	38.3	130.7	068	068	068	068
			CRHEATER424A00	50.0	5	10	45.9	156.7	068	068	068	068
		CRHEATER452A00	67.0	5	10	61.5	210.0	069	069	069	069	
		HIGH	CRHEATER420A00	15.0	5	10	13.8	47.0	067	067	067	067
			CRHEATER421A00	25.0	5	10	23.0	78.3	068	068	068	068
			CRHEATER422A00	33.0	5	10	30.3	103.4	068	068	068	068
			CRHEATER423A00	41.7	5	10	38.3	130.7	068	068	068	068
	CRHEATER424A00		50.0	5	10	45.9	156.7	068	068	068	068	
	575-3-60	STD/MED	CRHEATER425A00	18.0	5	—	16.5	56.4	067	067	067	067
			CRHEATER427A00	36.0	5	—	33.1	112.8	068	068	068	068
CRHEATER428A00			50.0	5	—	45.9	156.7	068	068	068	068	
HIGH		CRHEATER453A00	67.0	5	—	61.5	210.0	069	069	069	069	
		CRHEATER425A00	18.0	5	—	16.5	56.4	067	067	067	067	
		CRHEATER427A00	36.0	5	—	33.1	112.8	068	068	068	068	
		CRHEATER428A00	50.0	5	—	45.9	156.7	068	068	068	068	
		CRHEATER453A00	67.0	5	—	61.5	210.0	069	069	069	069	
		CRHEATER453A00	67.0	5	—	61.5	210.0	069	069	069	069	

NOTE(S):

a. High SCCR (Short Circuit Current Rating) is not available on units with Hot Gas Re-Heat system, powered convenience outlet, phase loss monitor, non-fused disconnect, or 575-v.

Electrical data (cont)

RAF180 Electric Heat Data — With Non-fused Disconnect

RAF UNIT SIZE	NOM. V-PH-Hz	IFM TYPE	ELECTRIC HEATER PART NUMBER	NOM (kW)	STD SCCR kA	APPLICATION (kW)	APPLICATION OUTPUT (MBH)	SINGLE POINT OR JUNCTION KIT PART NUMBER CRSINGLEXXXXA00				
								NO C.O. OR UNPOWERED C.O.		WITH PWRD C.O.		
								NO P.E.	WITH P.E. (pwrd fr/unit)	NO P.E.	WITH P.E. (pwrd fr/unit)	
RAF180	208/230-3-60	STD/ MED	CRHEATER412A00	16.0	5	12.0/14.7	41.0/50.1	049	049	049	049	
			CRHEATER414A00	25.0	5	18.8/23.0	64.1/78.3	049	049	049	049	
			CRHEATER415A00	32.0	5	24.0/29.4	82.0/100.3	049	049	049	049	
			CRHEATER416A00	42.4	5	31.8/38.9	108.7/132.9	051	051	051	051	
			CRHEATER417A00	50.0	5	37.6/45.9	128.1/156.7	051	051	051	051	
			CRHEATER451A00	67.0	5	50.3/61.5	171.7/210.0	053	053	053	053	
		HIGH	CRHEATER412A00	16.0	5	12.0/14.7	41.0/50.1	049	049	049	049	
			CRHEATER414A00	25.0	5	18.8/23.0	64.1/78.3	049	049	049	049	
			CRHEATER415A00	32.0	5	24.0/29.4	82.0/100.3	049	049	049	049	
			CRHEATER416A00	42.4	5	31.8/38.9	108.7/132.9	051	051	051	051	
			CRHEATER417A00	50.0	5	37.6/45.9	128.1/156.7	051	051	051	051	
			CRHEATER451A00	67.0	5	50.3/61.5	171.7/210.0	053	053	053	053	
		460-3-60	STD/ MED	CRHEATER420A00	15.0	5	13.8	47.0	—	—	—	—
				CRHEATER421A00	25.0	5	23.0	78.3	047	047	047	047
	CRHEATER422A00			33.0	5	30.3	103.4	047	047	047	047	
	CRHEATER423A00			41.7	5	38.3	130.7	050	050	050	050	
	CRHEATER424A00			50.0	5	45.9	156.7	050	050	050	050	
	CRHEATER452A00			67.0	5	61.5	210.0	052	052	052	052	
	HIGH		CRHEATER420A00	15.0	5	13.8	47.0	—	—	—	—	
			CRHEATER421A00	25.0	5	23.0	78.3	047	047	047	047	
			CRHEATER422A00	33.0	5	30.3	103.4	047	047	047	050	
			CRHEATER423A00	41.7	5	38.3	130.7	050	050	050	050	
			CRHEATER424A00	50.0	5	45.9	156.7	050	050	050	050	
			CRHEATER452A00	67.0	5	61.5	210.0	052	052	052	052	
	575-3-60		STD/ MED	CRHEATER425A00	18.0	5	16.5	56.4	—	—	—	—
				CRHEATER427A00	36.0	5	33.1	112.8	047	047	047	047
		CRHEATER428A00		50.0	5	45.9	156.7	047	047	047	047	
		CRHEATER453A00		67.0	5	61.5	210.0	052	052	052	052	
		HIGH	CRHEATER425A00	18.0	5	16.5	56.4	—	—	—	—	
			CRHEATER427A00	36.0	5	33.1	112.8	047	047	047	047	
CRHEATER428A00			50.0	5	45.9	156.7	047	047	047	050		
CRHEATER453A00			67.0	5	61.5	210.0	052	052	052	052		

Typical Control Wiring Diagram — RGF090-120 208-230/460/575-3-60 Unit with Electromechanical Controller and POL224 Economizer

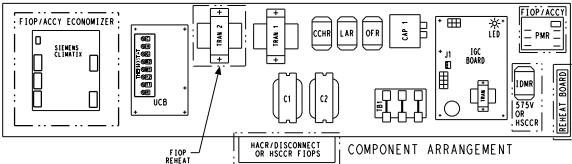

- NOTES:
1. UCB SCHEMATIC LAYOUT DOES NOT MATCH ACTUAL TERMINAL BOARD LAYOUT.
 2. TERMINAL BOARD JUMPERS 1, 2 AND 3 ARE CUT FOR REHEAT UNITS ONLY.
 3. REMOVE DESIGNATED JUMPERS ON UCB WHEN ADDING SMOKE DETECTORS, OCCUPANCY AND REMOTE SHUTDOWN.
 4. USE ABC AS COARSE AND POS AS FINE ADJUSTMENTS FOR SETTING HIGH FAN SPEED. LOW SPEED IS AN OFFSET BASED ON DIP SWITCHES.
 5. 2-PIN LOW SPEED DIP SWITCH POSITIONS ARE FACTORY SET AS SHOWN. EXCEPTION ONLY TO 8.5 TON UNITS, THESE ARE SET TO "ON-OFF".
 6. MAINSTAP AND CUTOFF SET TO "MIN". JUMPER PIN ON TOP 2-PINS AS SHOWN.
 7. THE # WIRE COLOR IS FOR DIFFERENTIATION WITHIN THIS SCHEMATIC.
 8. TRANSFORMER IS DEDICATED BASED ON UNIT VOLTAGE. TAPS ONLY SHOWN TO SIMPLIFY SCHEMATIC. 208/230V UNIT TRAN IS WIRED FOR 230V UNIT. IF UNIT IS TO BE RUN WITH 208V POWER SUPPLY DISCONNECT BLK WIRE FROM 230V TAP AND CONNECT TO 208V TAP.
 9. IGC P3 SETTING: 30 SEC.

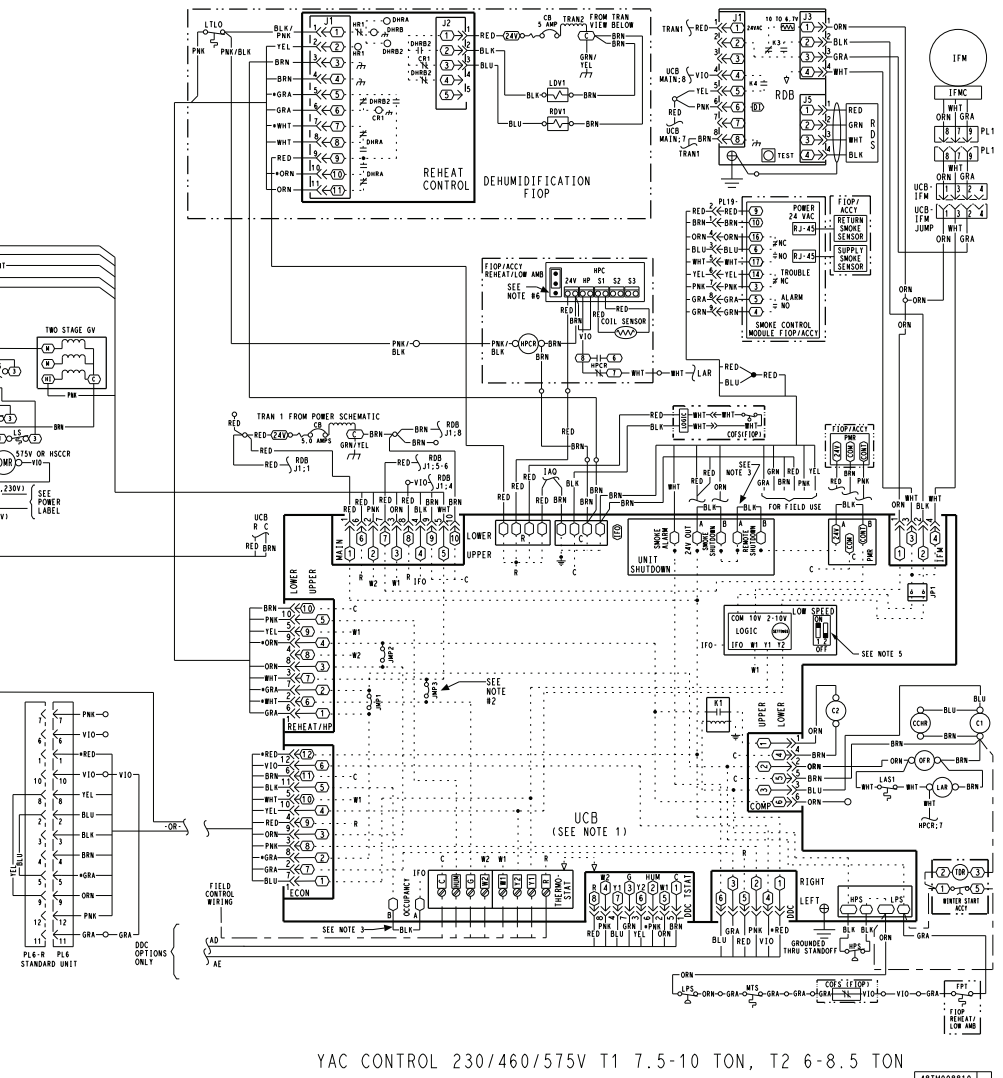
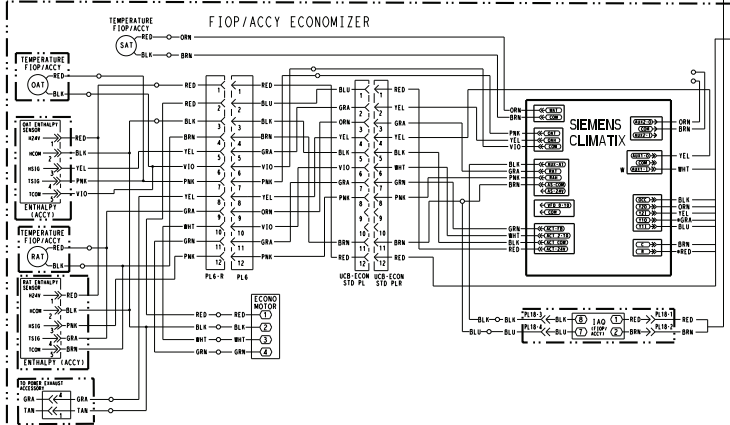
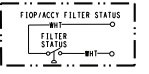
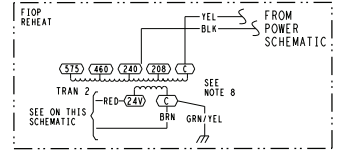

YAC CONTROL 230/460/575V T1 7.5-10 TON, T2 6-8.5 TON

48TMO0810

Typical wiring diagrams (cont)

Typical Power Wiring Diagram — RGF090-120 208-230/460-3-60 Unit with Electromechanical Controller

YAC POWER 230/460V
T1 7.5-10 TON
T2 6-8.5 TON

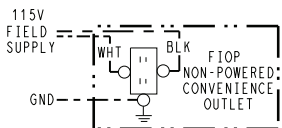
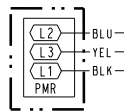
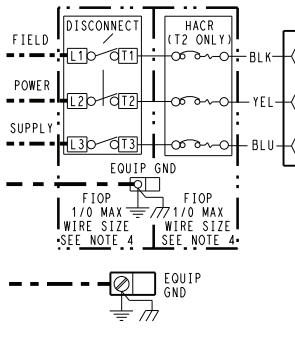

LEGEND

- (X) MARKED WIRE
- (X) TERMINAL (MARKED)
- () TERMINAL (UNMARKED)
- (X) TERMINAL BLOCK
- SPLICE
- (•) SPLICE (MARKED)
- FACTORY WIRING
- - - FIELD CONTROL WIRING
- - - FIELD POWER WIRING
- - - CIRCUIT BOARD TRACE
- - - ACCESSORY OR OPTIONAL WIRING
- TO INDICATE COMMON POTENTIAL ONLY: NOT TO REPRESENT WIRING

- NOTES:
- IF ANY OF THE ORIGINAL WIRE FURNISHED MUST BE REPLACED, IT MUST BE REPLACED WITH TYPE 90 C WIRE OR ITS EQUIVALENT.
 - COMPRESSOR AND FAN MOTORS ARE THERMALLY PROTECTED. THREE PHASE MOTORS ARE PROTECTED AGAINST PRIMARY SINGLE PHASING CONDITIONS.
 - USE COPPER CONDUCTOR ONLY.
 - YELLOW WIRE CONNECTED TO RESPECTIVE VOLTAGE TAP.
 - TRANSFORMER IS DEDICATED BASED ON UNIT VOLTAGE. TAPS ONLY SHOWN TO SIMPLIFY SCHEMATIC. 208/230V UNIT TRAN IS WIRED FOR 230V UNIT. IF UNIT IS TO BE RUN WITH 208V POWER SUPPLY DISCONNECT BLK WIRE FROM 230V TAP AND CONNECT TO 208V TAP.

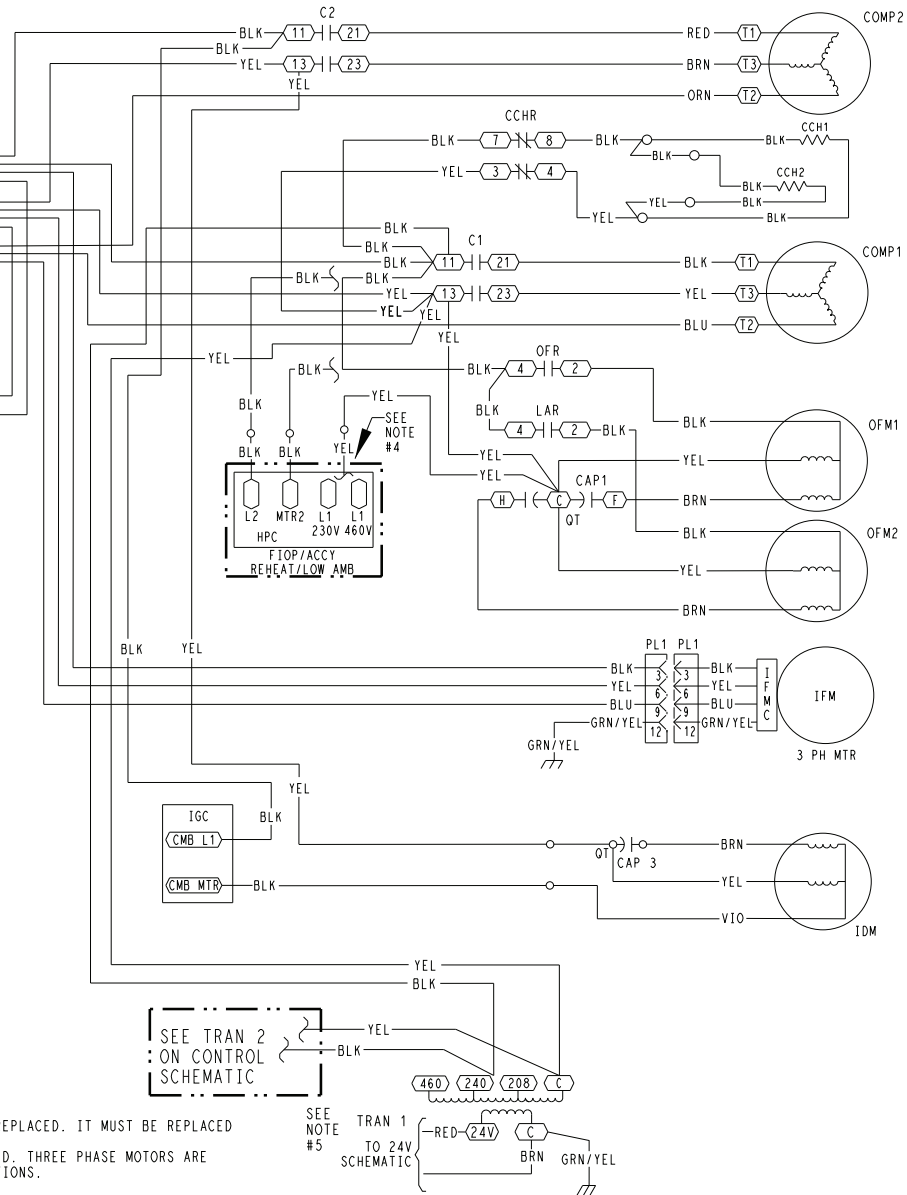

ACCY ACCESSORY
AMB AMBIENT
C CONTACTOR, COMPRESSOR
CAP CAPACITOR
CB CIRCUIT BREAKER
CCH CRANKCASE HEATER
CCHR CRANKCASE HEATER RELAY
CMB COMBUSTION
COFS CONDENSATE OVERFLOW SWT
COMP COMPRESSOR MOTOR
DDC DIRECT DIGITAL CONTROL
ERV ENERGY RECOVERY VENTILATOR
FIOF FACTORY INSTALLED OPTION
FLS FAN LIMIT SWITCH
FPT FREEZE PROTECTION THERMOSTAT
FSD FIRE SHUT DOWN
FS FLAME SENSOR
FU FUSE
GND GROUND
GVR GAS VALVE RELAY
HPC HEAD PRESSURE CONTROL
HPS HIGH PRESSURE SWITCH

HS HALL EFFECT SENSOR
I IGNITOR
IAQ INDOOR AIR QUALITY SENSORS
IDM INDUCED DRAFT MOTOR
IFCB INDOOR FAN CIRCUIT BREAKER
IFM INDOOR FAN MOTOR
IFMC INDOOR FAN CONTROLLER
IGC INTEGRATED GAS CONTROL
JMP JUMPER
LA LOW AMBIENT
LAR LOW AMBIENT RELAY
LDV LIQUID DIVERTER VALVE
LPS LOW PRESSURE SWITCH
LSM LIMIT SWITCH (MANUAL RESET)
LS LIMIT SWITCH
LTLO LOW TEMPERATURE LOCKOUT
MGV MAIN GAS VALVE
MOV VOLTAGE RESTRICTOR
MTR MOTOR
MTS MIXED AIR TEMPERATURE SWITCH
OAO OUTDOOR AIR QUALITY
OARH OUTSIDE AIR RELATIVE HUMIDITY
OAT OUTDOOR AIR TEMP. SENSOR

OFM OUTDOOR FAN MOTOR
OFR OUTDOOR FAN RELAY
OL OVERLOAD
PL PLUG ASSEMBLY
POT POTENTIOMETER
PMR PHASE MONITOR RELAY
POT QUADRUPLE TERMINAL
QT RETURN AIR RELATIVE HUMIDITY
RARH RETURN AIR TEMP. SENSOR
RAT REFRIGERANT DISSIPATION BOARD
RDB REFRIGERANT DISSIPATION SENSOR
RDS REHEAT DISCHARGE VALVE
RDV ROLLOUT SWITCH
RS SUPPLY AIR TEMP. SENSOR
SAT SENSOR
SEN SENSOR
SPRH SPACE RELATIVE HUMIDITY
SPT SPACE TEMPERATURE SENSOR
SPTO SPACE TEMPERATURE OFFSET
STD STANDARD
TB TERMINAL BLOCK
TDR TIME DELAY RELAY(WINTER START)
TRAN TRANSFORMER
UCB UNIT CONTROL BOARD

48TM005719 F

Typical Control Wiring Diagram — RGF150 208-230/460/575-3-60 Unit with Electromechanical Controller and POL224 Economizer

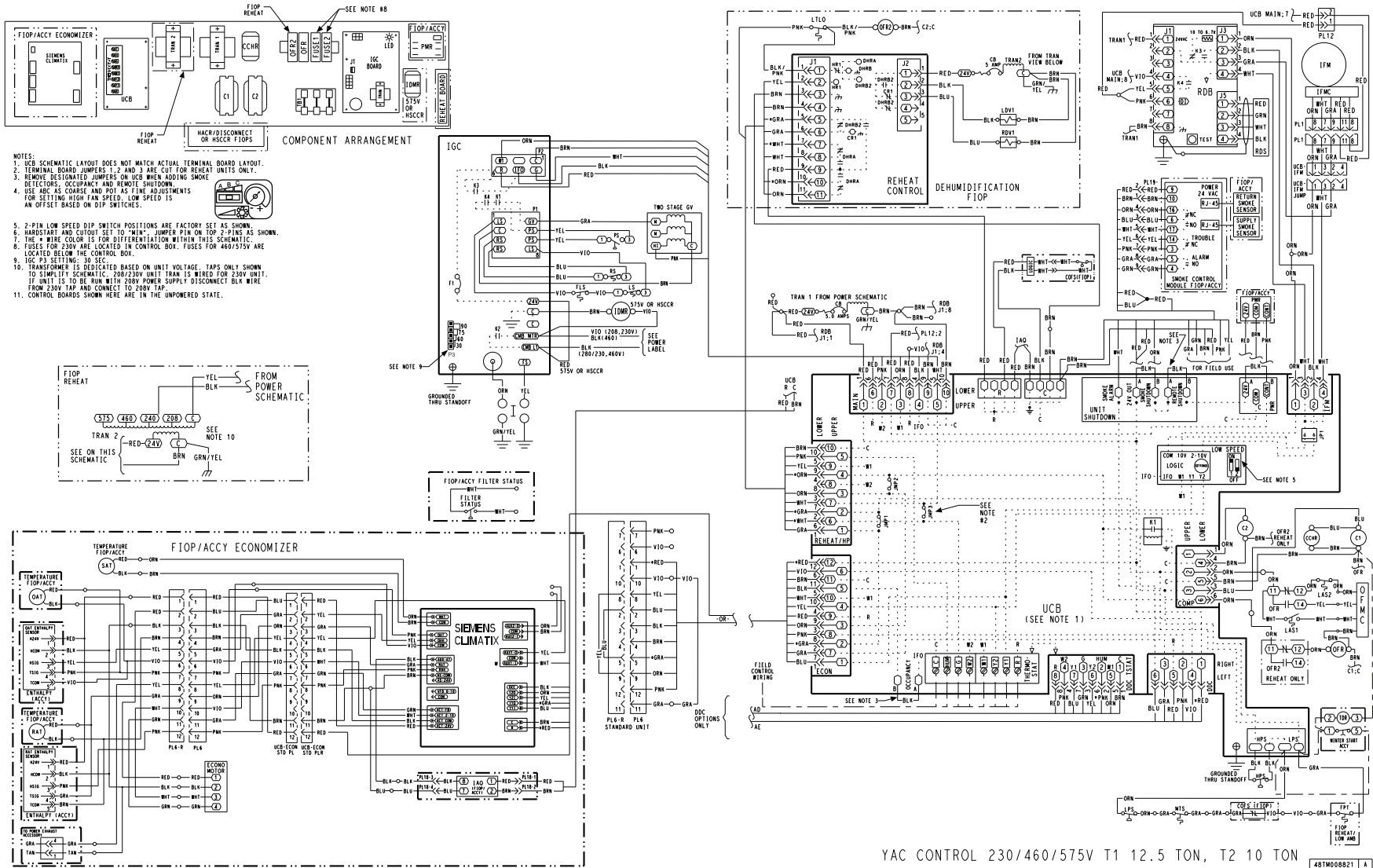

Typical wiring diagrams (cont)

Typical Power Wiring Diagram — RGF150 208-230/3/60 Unit with Electromechanical Controller

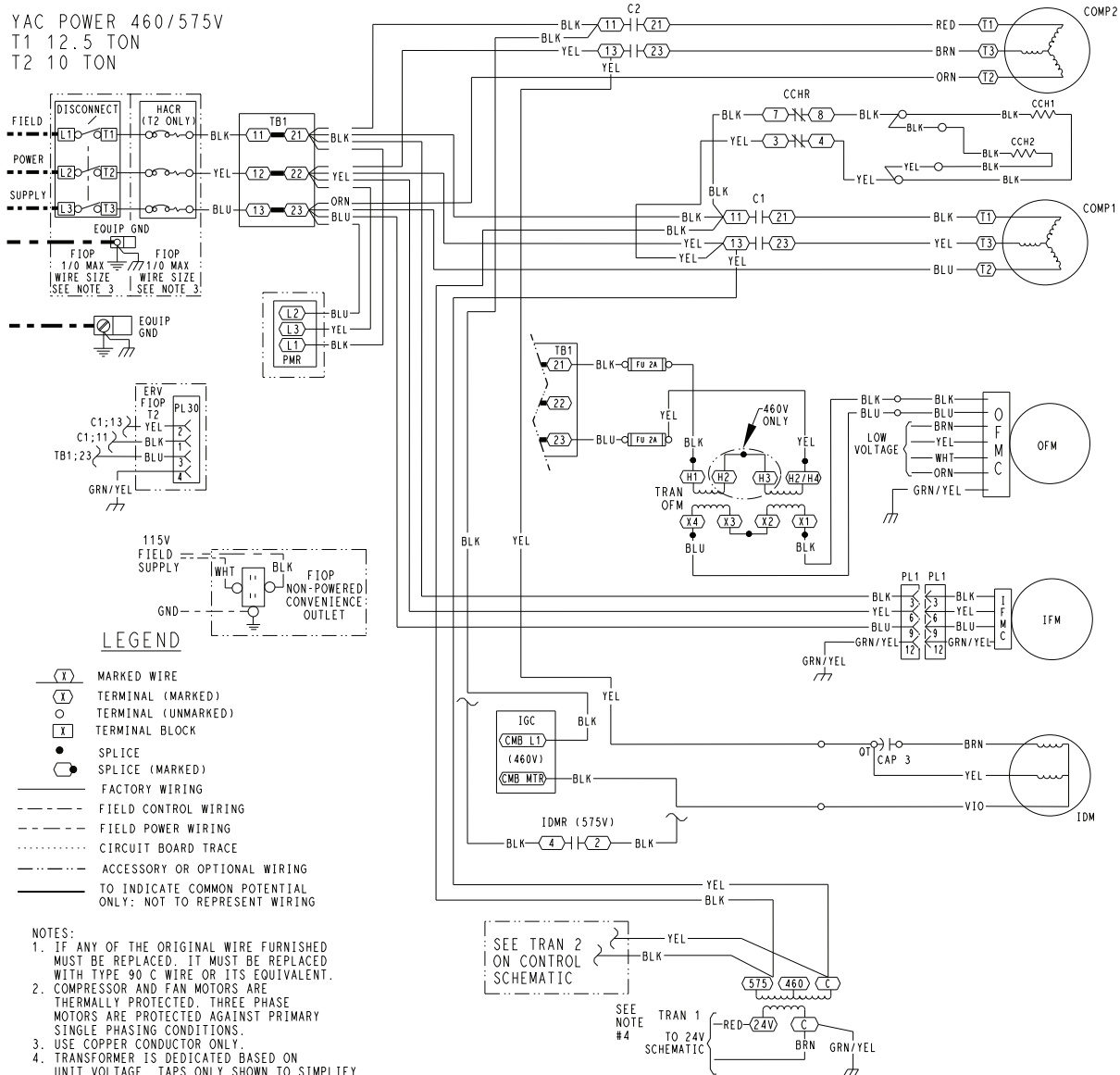

ACCY ACCESSORY
AMB AMBIENT
C CONTACTOR, COMPRESSOR
CAP CAPACITOR
CB CIRCUIT BREAKER
CCH CRANKCASE HEATER
CCHR CRANKCASE HEATER RELAY
CMB COMBUSTION
COFS CONDENSATE OVERFLOW SWT
COMP COMPRESSOR MOTOR
DDC DIRECT DIGITAL CONTROL
ERV ENERGY RECOVERY VENTILATOR
FIOP FACTORY INSTALLED OPTION
FLS FAN LIMIT SWITCH
FPT FREEZE PROTECTION THERMOSTAT
FSD FIRE SHUT DOWN
FS FUSE
FU FUSE
GND GROUND
GVR GAS VALVE RELAY
HPC HEAD PRESSURE CONTROL
HPS HIGH PRESSURE SWITCH

HS HALL EFFECT SENSOR
I IGNITOR
IAQ INDOOR AIR QUALITY SENSORS
IDM INDUCED DRAFT MOTOR
IFCB INDOOR FAN CIRCUIT BREAKER
IFM INDOOR FAN MOTOR
IFMC INDOOR FAN CONTROLLER
IGC INTEGRATED GAS CONTROL
JMP JUMPER
LA LOW AMBIENT
LDV LIQUID DIVERTER VALVE
LPS LOW PRESSURE SWITCH
LSM LIMIT SWITCH (MANUAL RESET)
LS LIMIT SWITCH
LTO LOW TEMPERATURE LOCKOUT
MGV MAIN GAS VALVE
MOV MOV
MTR MOTOR
MTS MIXED AIR TEMPERATURE SWITCH
OAO OUTDOOR AIR QUALITY
OARH OUTSIDE AIR RELATIVE HUMIDITY
OAT OUTDOOR AIR TEMP. SENSOR

OFM OUTDOOR FAN MOTOR
OFR OUTDOOR FAN RELAY
OL OVERLOAD
PL PLUG ASSEMBLY
POT POTENTIOMETER
PMR PHASE MONITOR RELAY
QT QUADRUPLE TERMINAL
RARH RETURN AIR RELATIVE HUMIDITY
RAT RETURN AIR TEMP. SENSOR
RDB REFRIGERANT DISSIPATION BOARD
RDS REFRIGERANT DISSIPATION SENSOR
RDV REHEAT DISCHARGE VALVE
RS ROLLOUT SWITCH
SAT SUPPLY AIR TEMP. SENSOR
SEN SENSOR
SPRH SPACE RELATIVE HUMIDITY
SPT SPACE TEMPERATURE SENSOR
SPTO SPACE TEMPERATURE OFFSET
STD STANDARD
TB TERMINAL BLOCK
TDR TIME DELAY RELAY (WINTER START)
TRAN TRANSFORMER
UCB UNIT CONTROL BOARD

48TM005990 E

Typical Control Wiring Diagram — RGF180 230/460/575-3-60 Unit with Electromechanical Controller and POL224 Economizer

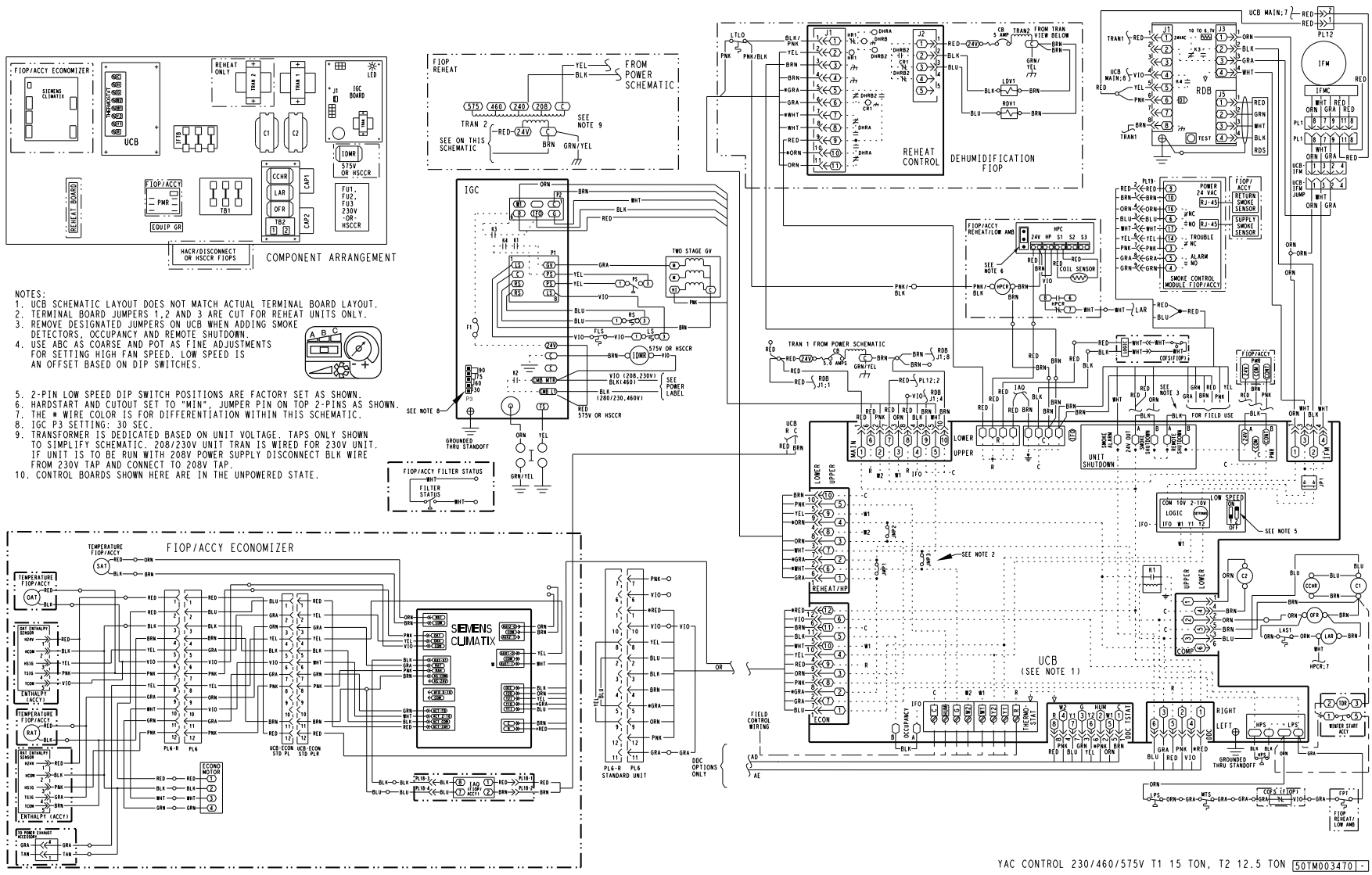

- NOTES:
1. UCB SCHEMATIC LAYOUT DOES NOT MATCH ACTUAL TERMINAL BOARD LAYOUT.
 2. TERMINAL BOARD JUMPERS 1, 2 AND 3 ARE CUT FOR REHEAT UNITS ONLY.
 3. REMOVE DESIGNATED JUMPERS ON UCB WHEN ADDING SMOKE DETECTORS, OCCUPANCY AND REMOTE SHUTDOWN.
 4. USE ABC AS COARSE AND POT AS FINE ADJUSTMENTS FOR SETTING HIGH FAN SPEED. LOW SPEED IS AN OFFSET BASED ON DIP SWITCHES.
 5. 2-PIN LOW SPEED DIP SWITCH POSITIONS ARE FACTORY SET AS SHOWN.
 6. HARDSTART AND CUTOFF SET TO "MIN". JUMPER PIN ON TOP 2-PINS AS SHOWN.
 7. THE * WIRE COLOR IS FOR DIFFERENTIATION WITHIN THIS SCHEMATIC.
 8. IGC P3 SETTING: 30 SEC.
 9. TRANSFORMER IS DEDICATED BASED ON UNIT VOLTAGE. TAPS ONLY SHOWN TO SIMPLIFY SCHEMATIC. 208/230V UNIT TRAN IS WIRED FOR 230V UNIT. IF UNIT IS TO BE RUN WITH 208V POWER SUPPLY DISCONNECT BLK WIRE FROM 230V TAP AND CONNECT TO 208V TAP.
 10. CONTROL BOARDS SHOWN HERE ARE IN THE UNPOWERED STATE.

YAC CONTROL 230/460/575V T1 15 TON, T2 12.5 TON 50TM003470-I

Typical wiring diagrams (cont)

Typical Power Wiring Diagram — RGF180 208-230/460-3-60 Unit with Electromechanical Controller

YAC POWER 208/230,460V T1 15 TON, T2 12.5 TON

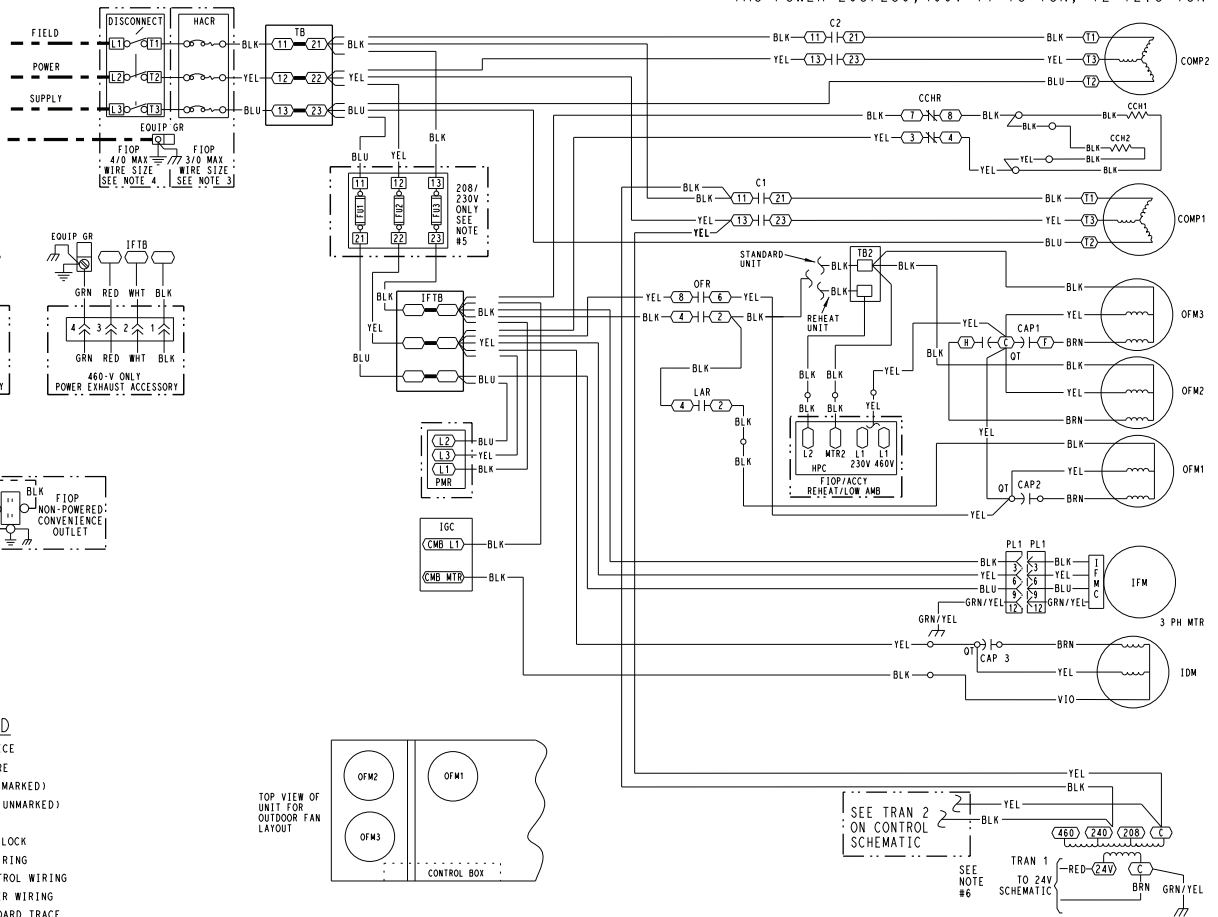

LEGEND

- FIELD SPLICE
- MARKED WIRE
- TERMINAL (MARKED)
- TERMINAL (UNMARKED)
- SPLICE
- TERMINAL BLOCK
- FACTORY WIRING
- FIELD CONTROL WIRING
- FIELD POWER WIRING
- CIRCUIT BOARD TRACE
- ACCESSORY OR FIOF
- TO INDICATE COMMON POTENTIAL ONLY: NOT TO REPRESENT WIRING

NOTES:

1. IF ANY OF THE ORIGINAL WIRE FURNISHED MUST BE REPLACED, IT MUST BE REPLACED WITH TYPE 90 C WIRE OR ITS EQUIVALENT.
2. COMPRESSOR AND FAN MOTORS ARE THERMALLY PROTECTED. THREE PHASE MOTORS ARE PROTECTED AGAINST PRIMARY SINGLE PHASING CONDITIONS.
3. USE COPPER, COPPER CLAD ALUMINUM OR ALUMINUM CONDUCTORS.
4. USE COPPER CONDUCTORS ONLY.
5. FUL, FUS, AND FUS3, REPLACE WITH 250V 60A BUSSMAN FNR 60.
6. TRANSFORMER IS DEDICATED BASED ON UNIT VOLTAGE. TAPS ONLY SHOWN TO SIMPLIFY SCHEMATIC. 208/230V UNIT TRAN IS WIRED FOR 230V UNIT. IF UNIT IS TO BE RUN WITH 208V POWER SUPPLY DISCONNECT BLK WIRE FROM 230V TAP AND CONNECT TO 200V TAP.

ACCY	ACCESSORY	I	IGNITOR	OFR	OUTDOOR FAN RELAY
AMB	AMBIENT	IAQ	INDOOR AIR QUALITY SENSORS	OL	OVERLOAD
C	CONTACTOR, COMPRESSOR	IDM	INDUCED DRAFT MOTOR	PL	PLUG ASSEMBLY
CAP	CAPACITOR	IFCB	INDOOR FAN CIRCUIT BREAKER	POT	POTENTIOMETER
CB	CIRCUIT BREAKER	IFM	INDOOR FAN MOTOR	PMR	PHASE MONITOR RELAY
CCH	CRANKCASE HEATER	IFMC	INDOOR FAN CONTROLLER	QT	QUADRUPLER TERMINAL
CCHR	CRANKCASE HEATER RELAY	IGC	INTEGRATED GAS CONTROL	RARH	RETURN AIR RELATIVE HUMIDITY
CMB	COMBUSTION	IGT	INDOOR FAN TERMINAL BLOCK	RAT	RETURN AIR TEMP. SENSOR
CFS	CONDENSATE OVERFLOW SWT	JMP	JUMPER	RDB	REFRIGERANT DISSIPATION BOARD
COMP	COMPRESSOR MOTOR	LA	LOW AMBIENT	RDS	REFRIGERANT DISSIPATION SENSOR
DDC	DIRECT DIGITAL CONTROL	LAR	LOW AMBIENT RELAY	RDV	REHEAT DISCHARGE VALVE
EDR	ELECTRIC HEATER RELAY	LDV	LIQUID DIVERTER VALVE	RS	ROLLOUT SWITCH
ERV	ENERGY RECOVERY VENTILATOR	LPS	LOW PRESSURE SWITCH	RVSF	REVERSING VALVE SOLENOID RELAY
FIOF	FACTORY INSTALLED OPTION	LSM	LIMIT SWITCH (MANUAL RESET)	SAT	SUPPLY AIR TEMP. SENSOR
FLS	FAN LIMIT SWITCH	LS	LIMIT SWITCH	SEN	SENSOR
FPT	FREEZE PROTECTION THERMOSTAT	LTLO	LOW TEMPERATURE LOCKOUT	SPRH	SPACE RELATIVE HUMIDITY
FPD	FIRE SHUT DOWN	MVD	MAIN GAS VALVE	SPT	SPACE TEMPERATURE SENSOR
FS	FLAME SENSOR	MOV	VOLTAGE RESTRICTOR	SPTO	SPACE TEMPERATURE OFF-SET
FU	FUSE	MTR	MOTOR	STD	STANDARD
GND	GROUND	MTS	MIXED AIR TEMPERATURE SWITCH	TB	TERMINAL BLOCK
GVR	GAS VALVE RELAY	OAO	OUTDOOR AIR QUALITY	TBR	TEMPERATURE BYPASS RELAY
HPC	HEAD PRESSURE CONTROL	OARH	OUTSIDE AIR RELATIVE HUMIDITY	TDR	TIME DELAY RELAY (WINTER START)
HPS	HIGH PRESSURE SWITCH	OAT	OUTDOOR AIR TEMP. SENSOR	TRAN	TRANSFORMER
HS	HALL EFFECT SENSOR	OFM	OUTDOOR FAN MOTOR	UCB	UNIT CONTROL BOARD

50TM001914 D

Typical Control Wiring Diagram — RAF090-120 208-230/460/575-3-60 Unit with Electromechanical Controller and POL224 Economizer

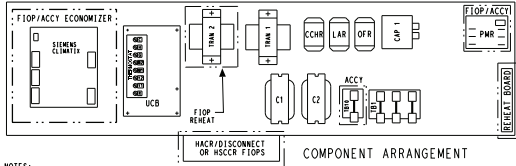

- NOTES:
1. TERMINAL BOARD SCHEMATIC LAYOUT DOES NOT MATCH ACTUAL TERMINAL BOARD LAYOUT.
 2. TERMINAL BOARD JUMPER 1, 2 AND 3 ARE CUT FOR REHEAT UNITS ONLY.
 3. REMOVE DESIGNATED JUMPERS ON TERMINAL BOARD WHEN ADDING SMOKE DETECTORS, OCCUPANCY AND REMOTE SHUTDOWN.
 4. USE ABC AS COARSE AND POT AS FINE ADJUSTMENTS FOR SETTING HIGH FAN SPEED. LOW SPEED IS AN OFFSET BASED ON DIP SWITCHES.
 5. 2-PIN LOW SPEED DIP SWITCH POSITIONS ARE FACTORY SET AS SHOWN. EXCEPTION ON T1 8.5 TON UNITS. THESE ARE SET TO "ON-OFF".
 6. HARDCSTART AND CUTOFF SET TO "MIN." JUMPER PIN ON TOP 2-PIN AS SHOWN. THE W WIRE COLOR IS FOR DIFFERENTIATION WITHIN THIS SCHEMATIC.
 7. TRANSFORMER IS DEDICATED BASED ON UNIT VOLTAGE. TAPS ONLY SHOWN TO SIMPLIFY SCHEMATIC. 208/230V UNIT TAP IS WIRED FOR 230V UNIT. IF UNIT IS TO BE RUN WITH 208V POWER SUPPLY DISCONNECT BLK WIRE FROM 230V TAP AND CONNECT TO 208V TAP.
 8. T84 LOCATED IN HEAT SECTION.
 9. TO CONVERT TO A SINGLE STAGE HEATER MOVE VIOLET WIRE AT T84 TO CONNECT WITH WHITE WIRE.
 10. CONTROL BOARDS SHOWN HERE ARE IN THE UNPOWERED STATE.
 11. CONTROL BOARDS SHOWN HERE ARE IN THE UNPOWERED STATE.

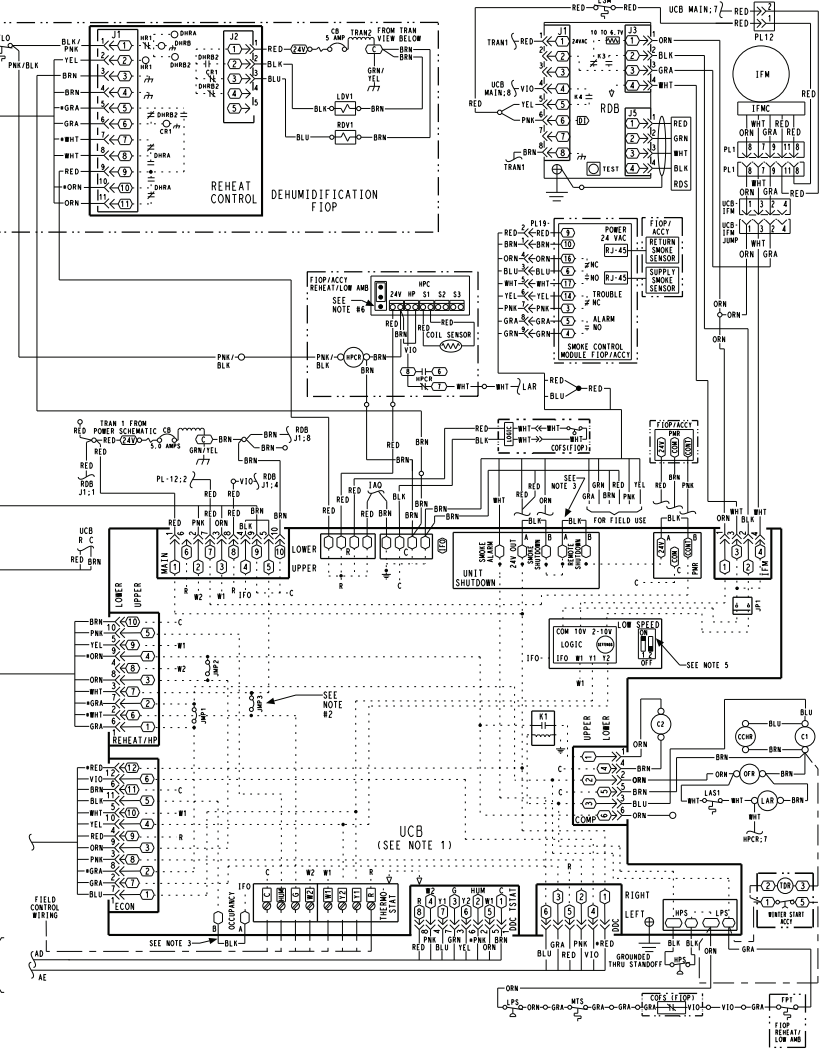
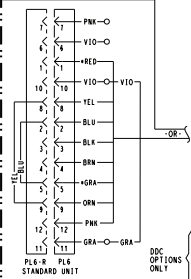
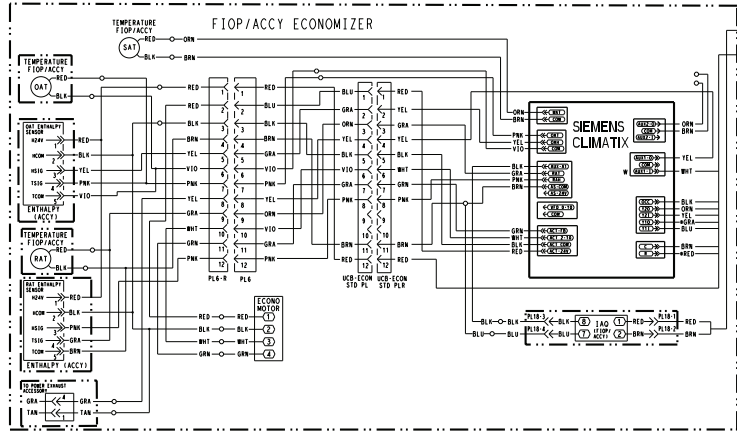
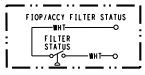
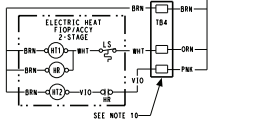
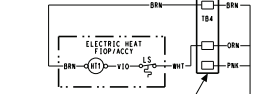
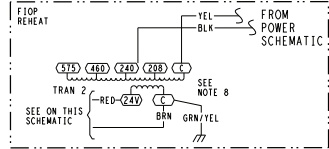

PAC CONTROL 230/460/575V T1 7.5-10 TON, T2 6-8.5 TON

48TMO0814 A

Typical wiring diagrams (cont)

Typical Power Wiring Diagram — RAF090-120 208-230/460-3-60 Unit with Electromechanical Controller

PAC POWER 230/460V
 T1 7.5-10 TON, T2 6-8.5 TON
 HP POWER 230/460V
 T1 7.5-8.5 TON,
 T2 6-7.5 TON

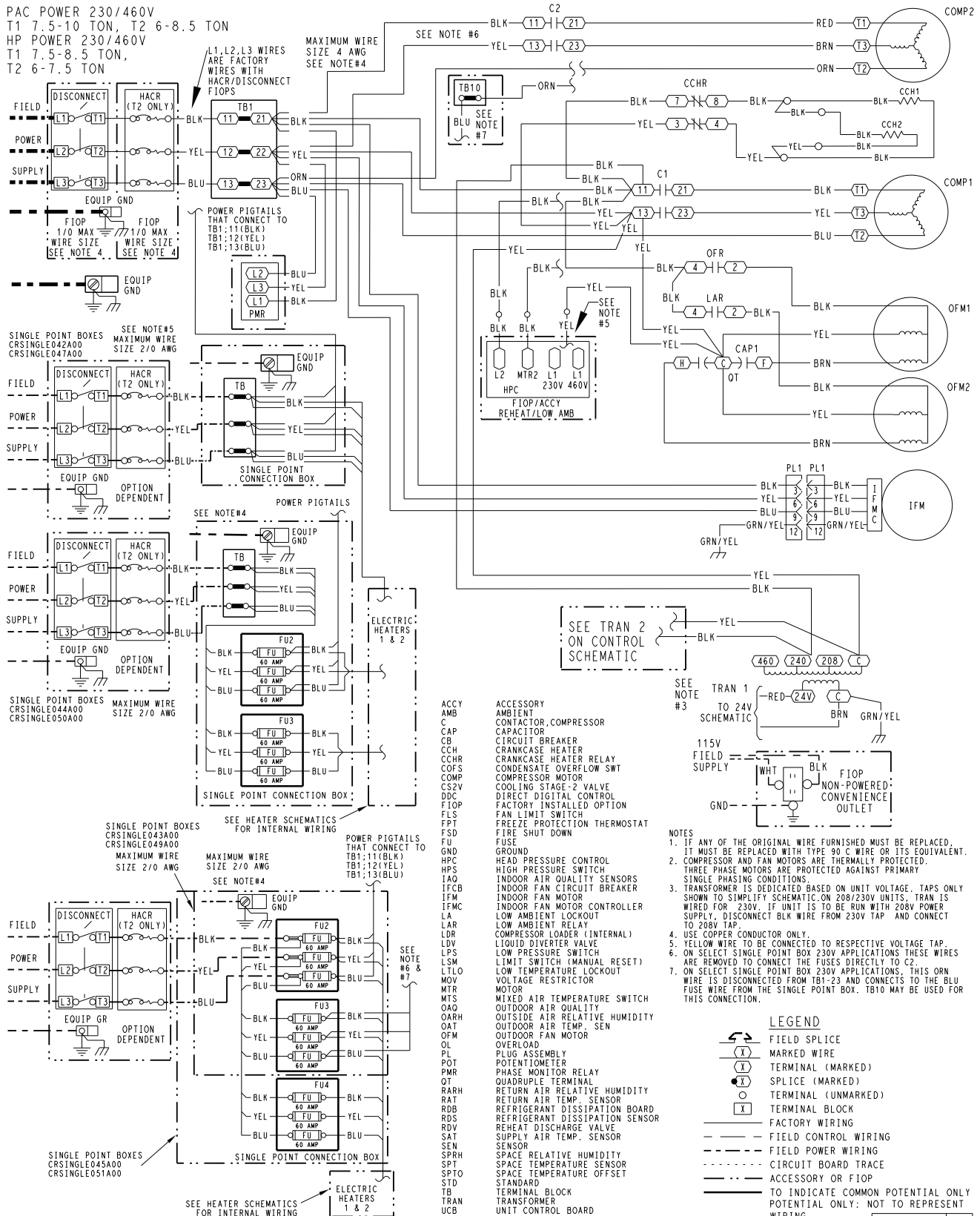

- ACCY AMB
- AMB
- CAP CB
- CCH CRANKCASE HEATER
- CCHR CRANKCASE HEATER RELAY
- COPS CONDENSATE OVERFLOW SWT
- COMP COMPRESSOR MOTOR
- CS2V COOLING STAGE-2 VALVE
- DDC DIRECT DIGITAL CONTROL
- F1OP FACTORY INSTALLED OPTION
- FAN FAN LIMIT SWITCH
- FRT FREEZE PROTECTION THERMOSTAT
- FSD FIRE SHUT DOWN
- FU FUSE
- GND GROUND
- HPC HEAD PRESSURE CONTROL
- HPS HIGH PRESSURE SWITCH
- IAO INDOOR AIR QUALITY SENSORS
- IFCB INDOOR FAN CIRCUIT BREAKER
- IFM INDOOR FAN MOTOR
- IFMC INDOOR FAN MOTOR CONTROLLER
- LA LOW AMBIENT LOCKOUT
- LAR LOW AMBIENT RELAY
- COMPR COMPRESSOR LOADER (INTERNAL)
- LDV LIQUID DIVERTER VALVE
- LPS LOW PRESSURE SWITCH
- LSM LIMIT SWITCH (MANUAL RESET)
- LTLO LOW TEMPERATURE LOCKOUT
- VRS VOLTAGE RESTRICTOR
- MTR MOTOR
- MIS MIXED AIR TEMPERATURE SWITCH
- OAO OUTDOOR AIR QUALITY
- OARH OUTSIDE AIR RELATIVE HUMIDITY
- OAT OUTDOOR AIR TEMP. SEN
- OFM OUTDOOR FAN MOTOR
- OL OVERLOAD
- PL PLUG ASSEMBLY
- POT POTENTIOMETER
- PMR PHASE MONITOR RELAY
- QT QUADRUPLE TERMINAL
- RARH RETURN AIR RELATIVE HUMIDITY
- RAT RETURN AIR TEMP. SENSOR
- RDB REFRIGERANT DISSIPATION BOARD
- RDS REFRIGERANT DISSIPATION SENSOR
- RDV REHEAT DISCHARGE VALVE
- SAT SUPPLY AIR TEMP. SENSOR
- SEN SENSOR
- SPRH SPACE RELATIVE HUMIDITY
- SPT SPACE TEMPERATURE SENSOR
- SPTO SPACE TEMPERATURE OFFSET
- STD STANDARD
- TB TERMINAL BLOCK
- TRAN TRANSFORMER
- UCB UNIT CONTROL BOARD

- NOTES
1. IF ANY OF THE ORIGINAL WIRE FURNISHED MUST BE REPLACED, IT MUST BE REPLACED WITH TYPE 90 C WIRE OR ITS EQUIVALENT.
 2. COMPRESSOR AND FAN MOTORS ARE THERMALLY PROTECTED. THREE PHASE MOTORS ARE PROTECTED AGAINST PRIMARY SINGLE PHASING CONDITIONS.
 3. TRANSFORMER IS DEDICATED BASED ON UNIT VOLTAGE. TAPS ONLY SHOWN TO SIMPLIFY SCHEMATIC. ON 208/230V UNITS, TRAN IS WIRED FOR 230V. IF UNIT IS TO BE RUN WITH 208V POWER SUPPLY, DISCONNECT BLK WIRE FROM 230V TAP AND CONNECT TO 208V TAP.
 4. USE COPPER CONDUCTOR ONLY.
 5. YELLOW WIRE TO BE CONNECTED TO RESPECTIVE VOLTAGE TAP.
 6. ON SELECT SINGLE POINT BOX 230V APPLICATIONS THESE WIRES ARE REMOVED TO CONNECT THE FUSES DIRECTLY TO C2.
 7. ON SELECT SINGLE POINT BOX 230V APPLICATIONS, THIS ORN WIRE IS DISCONNECTED FROM TB1-23 AND CONNECTS TO THE BLU FUSE WIRE FROM THE SINGLE POINT BOX. TB10 MAY BE USED FOR THIS CONNECTION.

LEGEND

- FIELD SPlice
- MARKED WIRE
- TERMINAL (MARKED)
- SPlice (MARKED)
- TERMINAL (UNMARKED)
- TERMINAL BLOCK
- FACTORY WIRING
- FIELD CONTROL WIRING
- FIELD POWER WIRING
- CIRCUIT BOARD TRACE
- ACCESSORY OR FIOP
- TO INDICATE COMMON POTENTIAL ONLY
POTENTIAL ONLY: NOT TO REPRESENT WIRING

48TM005717 G

Typical Control Wiring Diagram — RAF150 208-230/460/575-3-60 Unit with Electromechanical Controller and POL224 Economizer

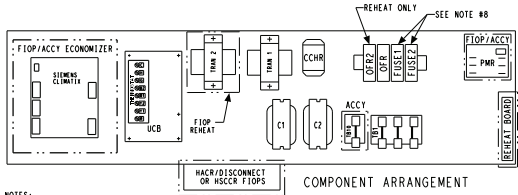

- NOTES:
1. UCB SCHEMATIC LAYOUT DOES NOT MATCH ACTUAL TERMINAL BOARD LAYOUT.
 2. TERMINAL BOARD JUMPERS 1, 2 AND 3 ARE CUT FOR REHEAT UNITS ONLY.
 3. REMOVE DESIGNATED JUMPERS ON UCB WHEN ADDING SMOKE DETECTORS, OCCUPANCY AND REMOTE SHUTDOWN.
 4. USE ABC AS COARSE AND ROT AS FINE ADJUSTMENTS FOR SETTING HIGH FAN SPEED. LOW SPEED IS AN OFFSET BASED ON DIP SWITCHES.
 5. 2-PIN LOW SPEED DIP SWITCH POSITIONS ARE FACTORY SET AS SHOWN.
 6. HARDSTART AND CUTOFF SET TO "MIN". JUMPER PIN ON TOP 2-PINS AS SHOWN.
 7. THE + WIRE COLOR IS FOR DIFFERENTIATION WITHIN THIS SCHEMATIC.
 8. FUSES FOR 230V ARE LOCATED IN CONTROL BOV. FUSES FOR 460/575V ARE LOCATED BELOW THE CONTROL BOX.
 9. T84 LOCATED IN HEAT SECTION.
 10. TO CONVERT TO A SINGLE STAGE HEATER MOVE VIOLET WIRE AT T84 TO CONNECT WITH WHITE WIRE.
 11. TRANSFORMER IS DEDICATED BASED ON UNIT VOLTAGE. TAPS ONLY SHOWN TO SIMPLIFY SCHEMATIC. 208/230V UNIT TRN1 IS WIRED FOR 230V UNIT. IF UNIT IS TO BE RUN WITH 208V POWER SUPPLY DISCONNECT BLK WIRE FROM 230V TAP AND CONNECT TO 208V TAP.
 12. CONTROL BOARDS SHOWN HERE ARE IN THE UNPOWERED STATE.

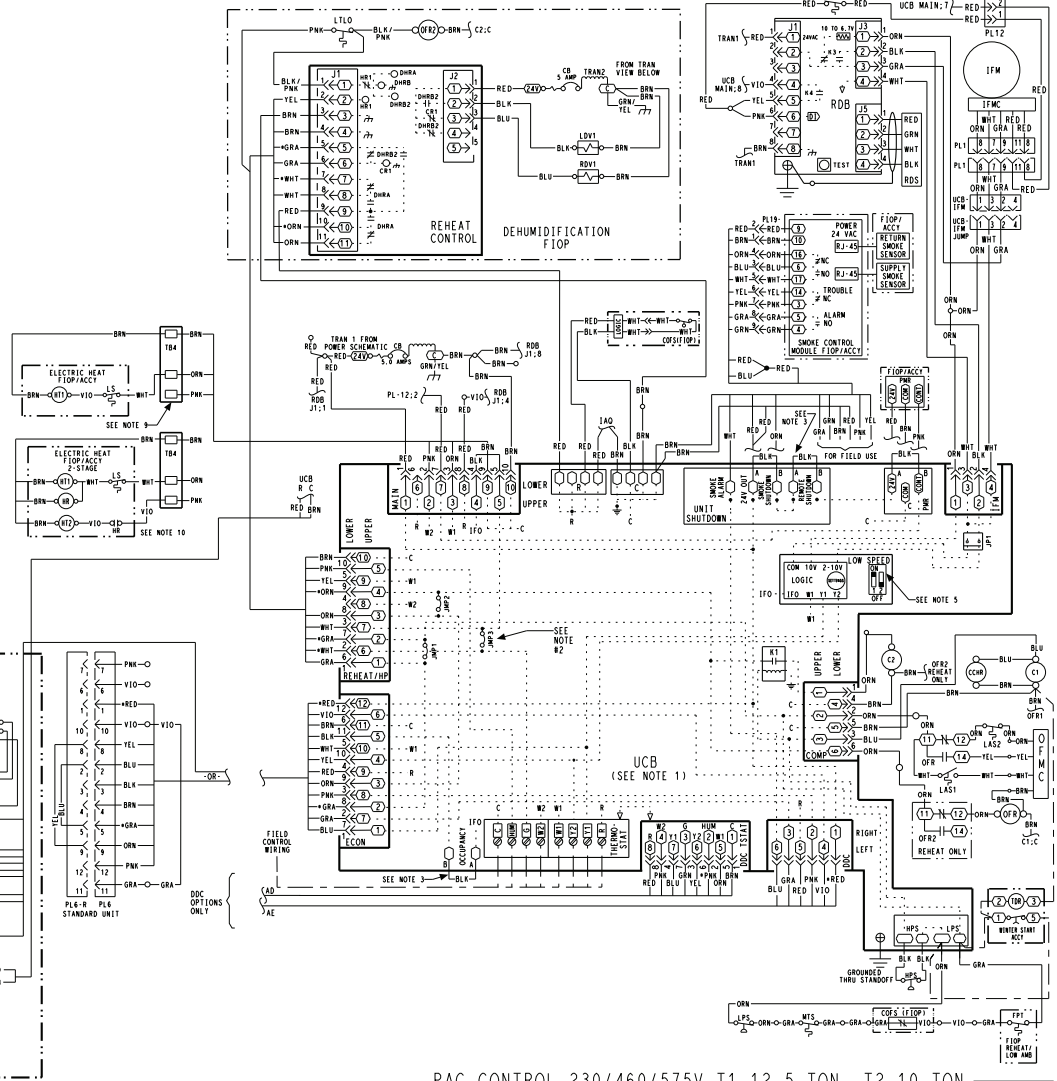
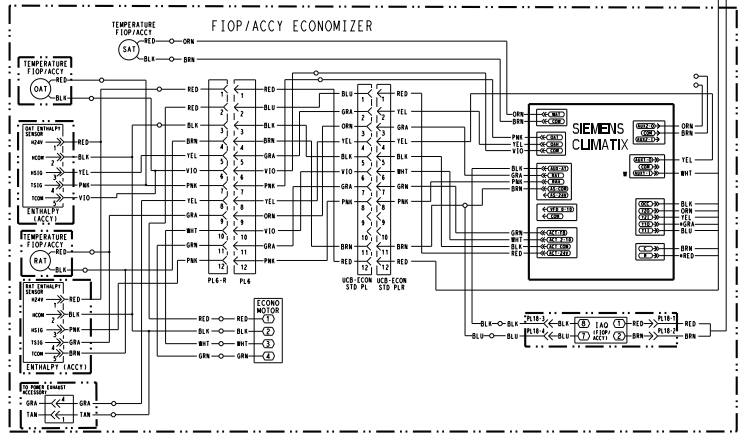
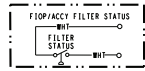
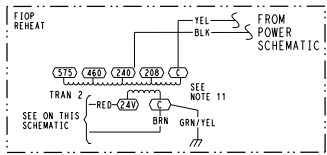

Typical wiring diagrams (cont)

Typical Power Wiring Diagram — RAF150 208-230/3/60 Unit with Electromechanical Controller

PAC POWER 460/575V
 T1 12.5 TON, T2 10 TON
 HP POWER 460/575V
 T1 10 TON, T2 8.5 TON

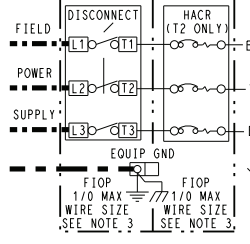
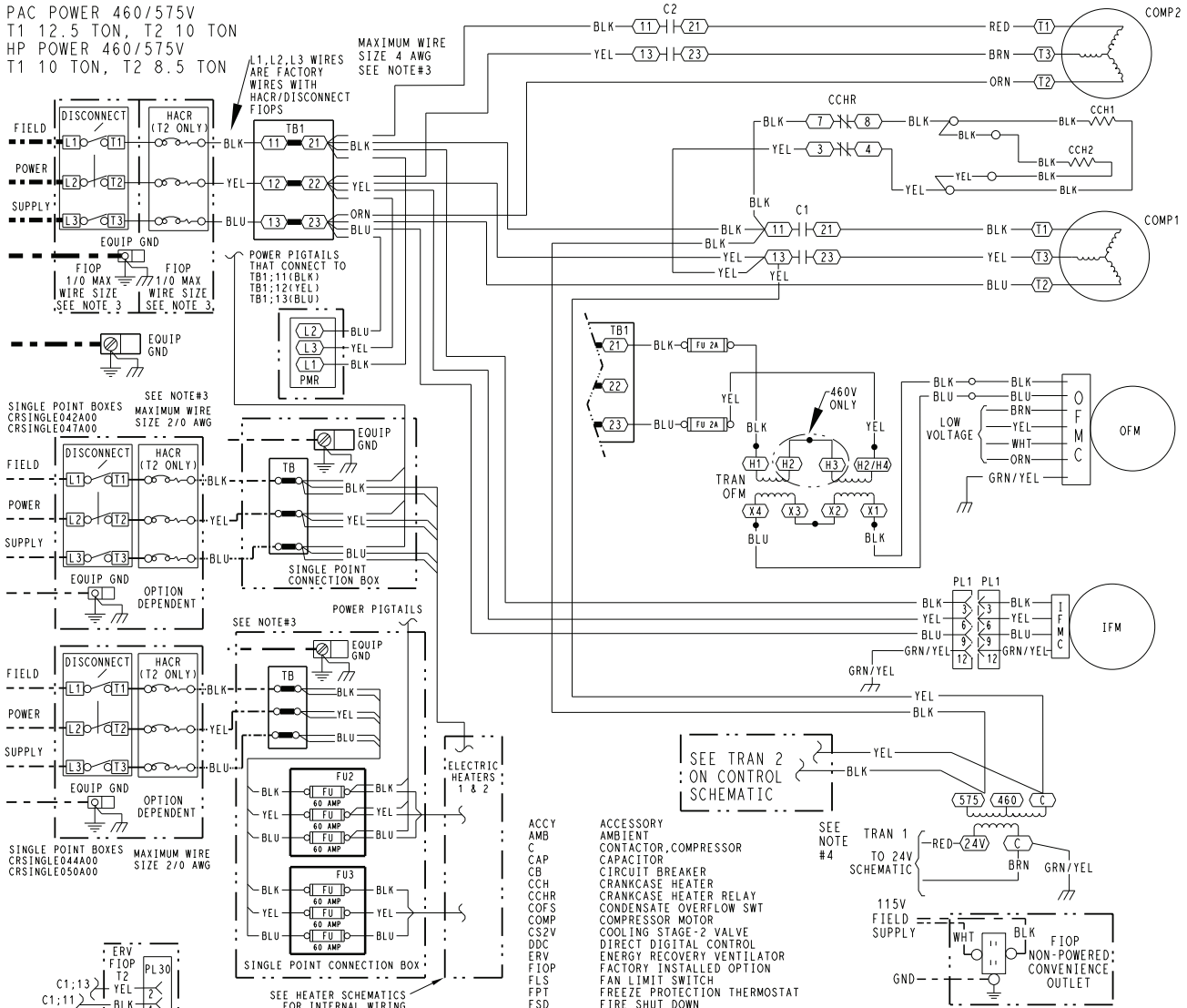

SINGLE POINT BOXES CR SINGLE 042A00
 SEE NOTE#3
 MAXIMUM WIRE SIZE 2/0 AWG

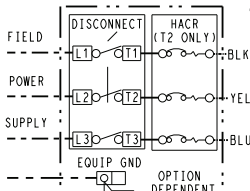
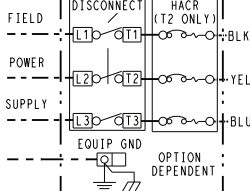

SINGLE POINT BOXES CR SINGLE 044A00
 CR SINGLE 050A00
 MAXIMUM WIRE SIZE 2/0 AWG

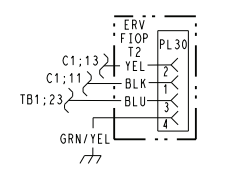

- ACCY AMBIENT CONTACTOR, COMPRESSOR CAPACITOR
- CB CIRCUIT BREAKER
- CH CRANKCASE HEATER
- CCHR CRANKCASE HEATER RELAY
- COFS CONDENSATE OVERFLOW SWT
- COMP COMPRESSOR MOTOR
- CS2VP COOLING STAGE-2 VALVE
- DDC DIRECT DIGITAL CONTROL
- ERV ENERGY RECOVERY VENTILATOR
- F1OP FACTORY INSTALLED OPTION
- FLS FAN LIMIT SWITCH
- FPT FREEZE PROTECTION THERMOSTAT
- FSD FIRE SHUT DOWN
- FU FUSE
- GND GROUND
- HPC HEAD PRESSURE CONTROL
- HPS HIGH PRESSURE SWITCH
- IAQ INDOOR AIR QUALITY SENSORS
- IFCB INDOOR FAN CIRCUIT BREAKER
- IFM INDOOR FAN MOTOR
- IFMC INDOOR FAN MOTOR CONTROLLER
- LA LOW AMBIENT LOCKOUT
- LDR COMPRESSOR LOADER (INTERNAL)
- LDV LIQUID DIVERTER VALVE
- LPS LOW PRESSURE SWITCH
- LSM LIMIT SWITCH (MANUAL RESET)
- LTLQ LOW TEMPERATURE LOCKOUT
- MOV VOLTAGE RESTRICTOR
- MTR MOTOR
- MTS MIXED AIR TEMPERATURE SWITCH
- OAG OUTDOOR AIR QUALITY
- OARH OUTSIDE AIR RELATIVE HUMIDITY
- OAT OUTDOOR AIR TEMP. SEN
- OFM OUTDOOR FAN MOTOR
- OL OVERLOAD
- PL PLUG ASSEMBLY
- POT POTENTIOMETER
- PMR PHASE MONITOR RELAY
- QT QUADRUPLE TERMINAL
- RARH RETURN AIR RELATIVE HUMIDITY
- RAT RETURN AIR TEMP. SENSOR
- RDB REFRIGERANT DISSIPATION BOARD
- RDS REFRIGERANT DISSIPATION SENSOR
- RDV REHEAT DISCHARGE VALVE
- SAT SUPPLY AIR TEMP. SENSOR
- SEN SENSOR
- SPRH SPACE RELATIVE HUMIDITY
- SPT SPACE TEMPERATURE SENSOR
- SPTO SPACE TEMPERATURE OFFSET STANDARD
- STO STANDARD
- TB TERMINAL BLOCK
- TRAN TRANSFORMER
- UCB UNIT CONTROL BOARD

- NOTES
- IF ANY OF THE ORIGINAL WIRE FURNISHED MUST BE REPLACED, IT MUST BE REPLACED WITH TYPE 90 C WIRE OR ITS EQUIVALENT.
 - COMPRESSOR AND FAN MOTORS ARE THERMALLY PROTECTED. THREE PHASE MOTORS ARE PROTECTED AGAINST PRIMARY SINGLE PHASING CONDITIONS.
 - USE COPPER CONDUCTOR ONLY.
 - TRANSFORMER IS DEDICATED BASED ON UNIT VOLTAGE. TAPS ONLY SHOWN TO SIMPLIFY SCHEMATIC.

LEGEND

- FIELD SPICE
- MARKED WIRE
- TERMINAL (MARKED)
- SPICE (MARKED)
- TERMINAL (UNMARKED)
- TERMINAL BLOCK
- FACTORY WIRING
- FIELD CONTROL WIRING
- FIELD POWER WIRING
- CIRCUIT BOARD TRACE
- ACCESSORY OR F1OP
- TO INDICATE COMMON POTENTIAL ONLY: NOT TO REPRESENT WIRING

48TM005987 F

Typical Control Wiring Diagram — RAF180 230/460/575-3-60 Unit with Electromechanical Controller and POL224 Economizer

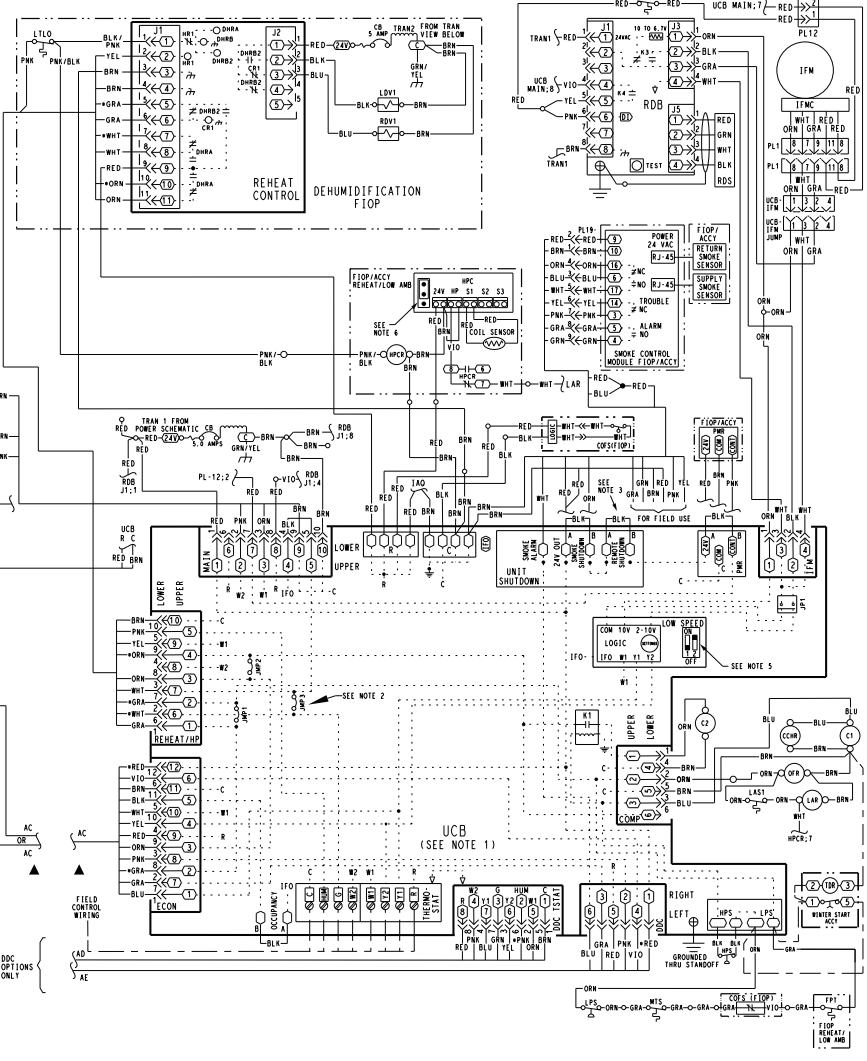
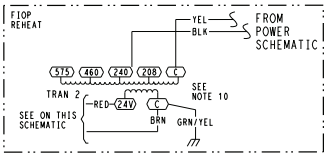
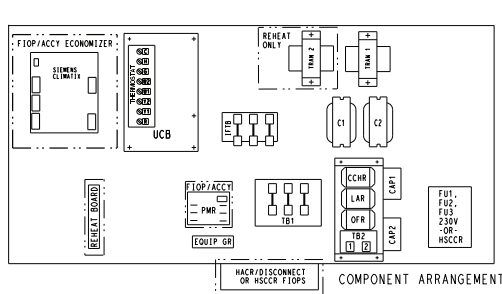

- NOTES:
1. UCB LAYOUT DOES NOT MATCH ACTUAL TERMINAL BOARD LAYOUT.
 2. TERMINAL BOARD JUMPERS 1,2 AND 3 ARE CUT FOR REHEAT UNITS ONLY.
 3. REMOVE DESIGNATED JUMPERS ON TERMINAL BOARD WHEN ADDING SMOKE DETECTORS, OCCUPANCY AND REMOTE SHUTDOWN.
 4. USE ABC AS COARSE AND POT AS FINE ADJUSTMENTS FOR SETTING HIGH FAN SPEED. LOW SPEED IS AN OFFSET BASED ON DIP SWITCHES.
 5. 2-PIN LOW SPEED DIP SWITCH POSITIONS ARE FACTORY SET AS SHOWN.
 6. HARDSTART AND CUTOFF SET TO "MIN". JUMPER PIN ON TOP 2-PINS AS SHOWN.
 7. THE * WIRE COLOR IS FOR DIFFERENTIATION WITHIN THIS SCHEMATIC.
 8. TB4 LOCATED IN HEAT SECTION.
 9. TO CONVERT TO A SINGLE STAGE HEATER MOVE VIOLET WIRE AT TB4 TO CONNECT WITH WHITE WIRE.
 10. TRANSFORMER IS DEDICATED BASED ON UNIT VOLTAGE. TAPS ONLY SHOWN TO SIMPLIFY SCHEMATIC. 208/230V UNIT TRAN IS WIRED FOR 230V UNIT. IF UNIT IS TO BE RUN WITH 208V POWER SUPPLY DISCONNECT BLK WIRE FROM 230V TAP AND CONNECT TO 208V TAP.
 11. CONTROL BOARDS SHOWN HERE ARE IN THE UNPOWERED STATE.

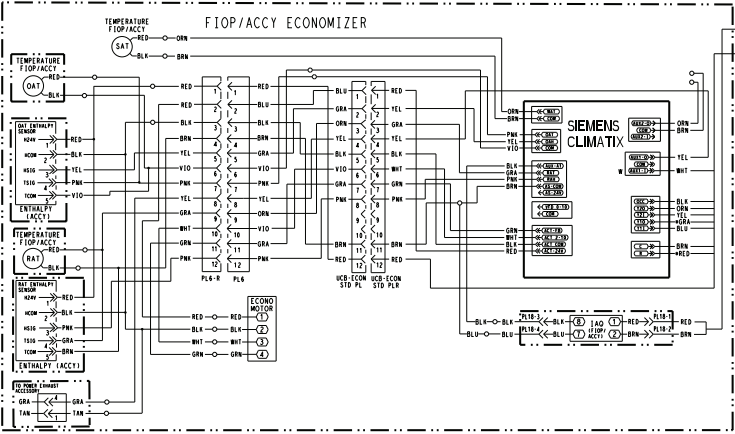

PAC CONTROL 230/460/575V T1 15 TON, T2 12.5 TON [50TM003469]

Typical wiring diagrams (cont)

Typical Power Wiring Diagram — RAF180 208-230/460-3-60 Unit with Electromechanical Controller

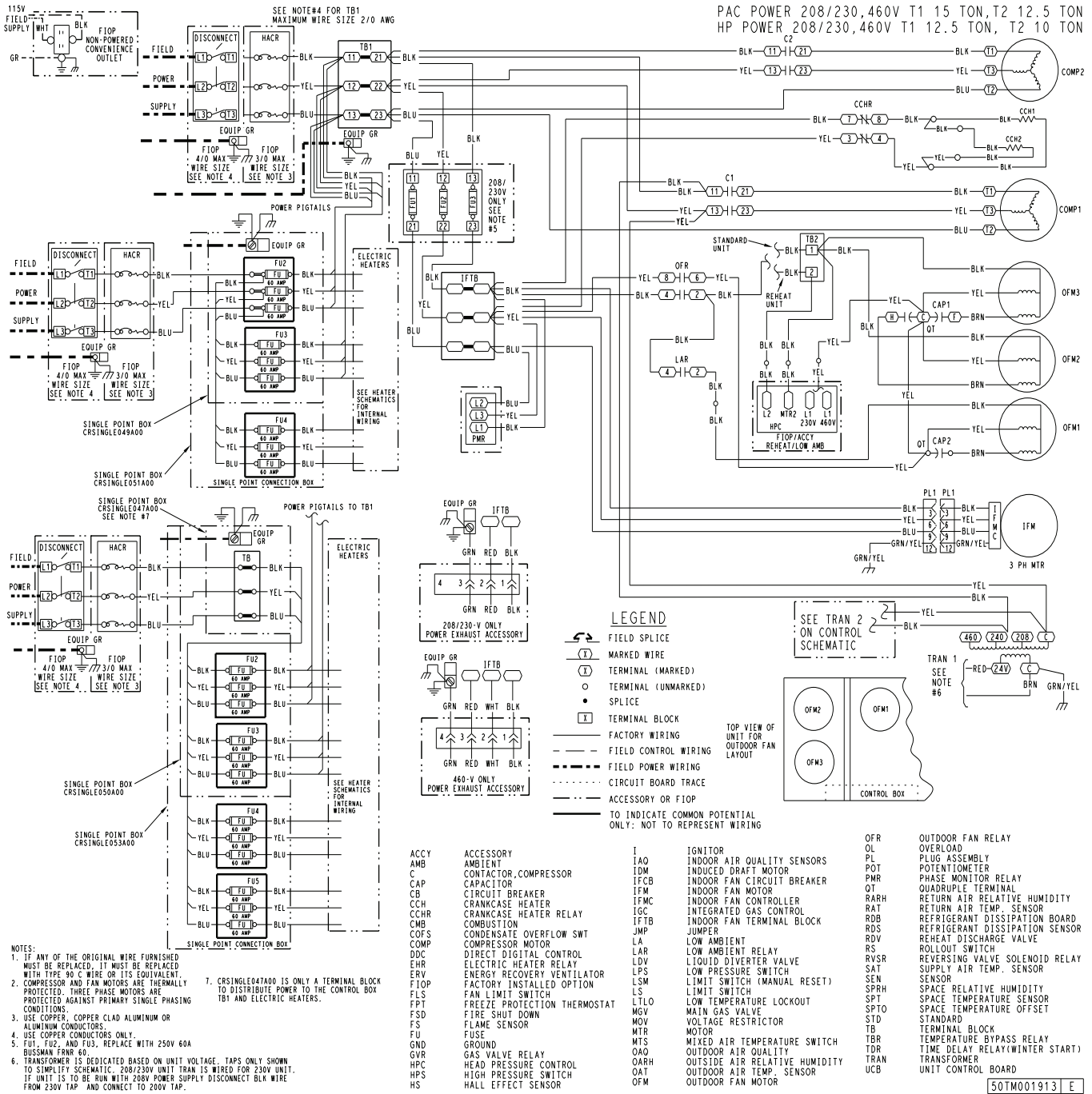

Sequence of operation

General

The sequence below describes the sequence of operation for an electromechanical unit with and without a factory-installed EconomizerONE (POL224 controller). For information regarding a direct digital controller, see the start-up, operations, and troubleshooting manual for the applicable controller.

Dissipation

When the factory-installed dissipation system detects a level of refrigerant leak in the unit, a safety dissipation mode will be activated. During this dissipation mode, the thermostat will be disabled and the indoor fan will run at 66% of the maximum speed of the motor. When the refrigerant leak levels are normal for 5 minutes, the unit will return to normal operation.

Electromechanical units without economizer

Cooling (2-stage units)

When the thermostat calls for cooling, terminals G and Y1 are energized. The indoor fan will run at the low fan speed and the C1 compressor contactor (CC) is energized causing the compressor and outdoor fan to run. The low indoor fan speed is 50% or 60% of the user set fan speed depending on unit size.

If additional cooling is needed, the thermostat will add the call for Y2. This will increase the indoor fan speed to the user set fan speed and energize the C2 contactor and second compressor for full compressor capacity. The outdoor fan is the same speed for Y1 and Y2.

When the thermostat removes the call for Y2 but leaves the Y1, the indoor fan will slow to the reduced percentage of the user set fan speed, the C2 contactor will de-energize, the second compressor will turn off, and the outdoor fan will remain on. When the thermostat removes the call for Y1 the compressor contactor will de-energize shutting down the compressor and the outdoor fan. When the thermostat removes the call for G, the indoor fan will turn off after the specific unit fan off delay.

NOTE: Per ASHRAE 90.1-2019 and IECC-2018 standards, during the first stage cooling operation the Unit Control Board (UCB) will adjust the fan motor speed to provide 50% or 60% of the total cfm established for the unit.

Gas heating (RGF units)

NOTE: RGF units have 2 stages of gas heat.

When the thermostat calls for heating, power is sent to W on the Integrated Gas Controller (IGC) board. An LED (light-emitting diode) on the IGC board turns on and remains on during normal operation. A check is made to ensure that the roll-out switch and limit switch are closed. If the check was successful, the induced-draft motor is energized, and when its speed is satisfactory, as proven by the flue gas pressure switch, the ignition activation period begins. The burners will ignite within 5 seconds. If the burners do not light, there is a 22 second delay before another 5 second attempt. This sequence is repeated for 15 minutes or until the burners

light. If, after the 15 minutes, the burners still have not lit, heating is locked out. To reset the control, break 24 V power to the thermostat.

When ignition occurs, the IGC board will continue to monitor the condition of the roll-out switch, the limit switches, the flue gas pressure switch, as well as the flame sensor. 45 seconds after ignition occurs, assuming the unit is controlled through a room thermostat set for fan auto, the indoor-fan motor will energize (and the outdoor-air dampers will open to their minimum position). If, for some reason, the over-temperature limit opens prior to the start of the indoor fan blower, the unit will shorten the 45 second delay to 5 seconds less than the time from initiation of heat to when the limit tripped. Gas will not be interrupted to the burners and heating will continue. Once the fan-on delay has been modified, it will not change back to 45 seconds until power is reset to the control. On units with 2 stages of heat, when additional heat is required, W2 closes and initiates power to the second stage of the main gas valve. When the thermostat is satisfied, W1 and W2 open and the gas valve closes, interrupting the flow of gas to the main burners. If the unit is controlled through a room thermostat set for fan auto, the indoor-fan motor will continue to operate for an additional 45 seconds then stop. A LED indicator is provided on the IGC to monitor operation.

Electric heating (RAF units)

NOTE: RAF units are sold as cooling only. If electric heaters are required, use only factory-approved heaters. They will operate as follows.

Units have either 1 or 2 stages of electric heat. When the thermostat calls for heating, power is applied to G and the W1 terminals at the unit. The unit control will energize the indoor fan contactor and the first stage of electric heat. On units with two-stage heating, when additional heating is required, the second stage of electric heat (if equipped) will be energized when power is applied at the W2 terminal on the unit.

IMPORTANT: The thermostat must be configured for Electric Heat so it will energize G with the W1 call.

Electromechanical units with factory-installed EconomizerONE

When free cooling is not available, the compressors will be controlled by the zone thermostat. When free cooling is available, the outdoor-air damper is modulated by the EconomizerONE control to provide a 50°F (10°C) to 55°F (13°C) mixed-air temperature into the zone. As the mixed air temperature fluctuates above 55°F (13°C) or below 50°F (10°C) dampers will be modulated (open or close) to bring the mixed-air temperature back within control. If mechanical cooling is utilized with free cooling, the outdoor-air damper will maintain its current position at the time the compressor is started. If the increase in cooling capacity causes the mixed-air temperature to drop below 45°F (7°C), then the outdoor-air damper position will be decreased to the minimum position. If the mixed-air temperature continues to fall, the outdoor-air damper will

Sequence of operation (cont)

close. Control returns to normal once the mixed-air temperature rises above 48°F (9°C). The power exhaust fans will be energized and de-energized, if installed, as the outdoor-air damper opens and closes.

If field-installed accessory CO₂ sensors are connected to the EconomizerONE control, a demand controlled ventilation strategy will begin to operate. As the CO₂ level in the zone increases above the CO₂ setpoint (on the EconomizerONE controller), the minimum position of the damper will be increased proportionally until the Maximum Ventilation setting is reached. As the CO₂ level decreases because of the increase in fresh air, the outdoor-air damper will follow the higher demand condition from either the DCV mode or from the free cooling mode. For EconomizerONE operation, there must be a thermostat call for the fan (G). If the unit is occupied and the fan is on, the damper will operate at minimum position. Otherwise, the damper will be closed.

When the EconomizerONE control is in the occupied mode and a call for cooling exists (Y1 on the thermostat), the control will first check for indoor fan operation. If the fan is not on, then cooling will not be activated. If the fan is on, then the control will open the EconomizerONE damper to the minimum position.

On the initial power to the EconomizerONE control, it will take the damper up to 2 1/2 minutes before it begins to position itself. After the initial power-up, further changes in damper position can take up to 90 seconds to initiate. Damper movement from full closed to full open (or vice versa) will take between 1 1/2 and 2 1/2 minutes. If free cooling can be used as determined from the appropriate changeover command (dry bulb, outdoor enthalpy, differential dry bulb, or differential enthalpy), then the control will modulate the dampers open and closed to maintain the mixed-air temperature setpoint at 50°F (10°C) to 55°F (13°C). If there is a further demand for cooling (cooling second stage — Y2 is energized), then the control will bring on compressor stage 1 to maintain the mixed-air temperature setpoint. The EconomizerONE damper will be open at maximum position.

NOTE: For 2-speed units, the EconomizerONE controller will adjust the damper position as the Indoor Fan Speed changes, per its configured values.

Heating

The sequence of operation for heating is the same as an electromechanical unit without an economizer. The only difference is how the economizer acts. The economizer will stay at the Economizer Minimum Position while the evaporator fan is operating. The outdoor-air damper is closed when the indoor fan is not operating. Refer to Service and Maintenance manual for further details.

Optional Hot Gas Re-Heat dehumidification system

Units with the factory equipped Hot Gas Re-Heat system option are capable of providing multiple modes of improved dehumidification as a variation of the normal cooling cycle. The Hot Gas Re-Heat system option includes additional valves in the liquid line and discharge line of each refrigerant circuit, a small reheat condenser coil downstream of the evaporator, and variable-speed control of some or all outdoor fans. Operation of the revised refrigerant circuit for each mode is described below.

The Hot Gas Re-Heat system provides three sub-modes of operation: Cool, Reheat1, and Reheat2.

Cool mode — Provides a normal ratio of Sensible and Latent Cooling effect from the evaporator coil.

Reheat1 — Provides increased Latent Cooling while slightly reducing the Sensible Cooling effect.

Reheat2 — Provides normal Latent Cooling but with null or minimum Sensible Cooling effect delivered to the space.

The Reheat1 and Reheat2 modes are available when the unit is not in a Heating mode and when the Low Ambient Lockout switch is closed.

Refer to the following figures for piping flow diagrams.

Sequence of operation (cont)

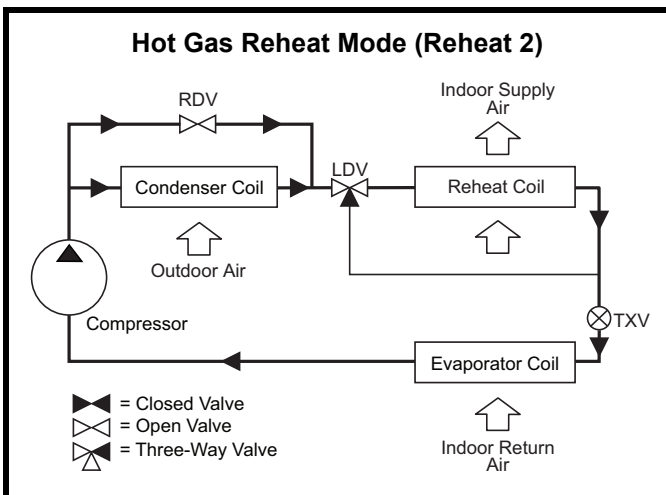
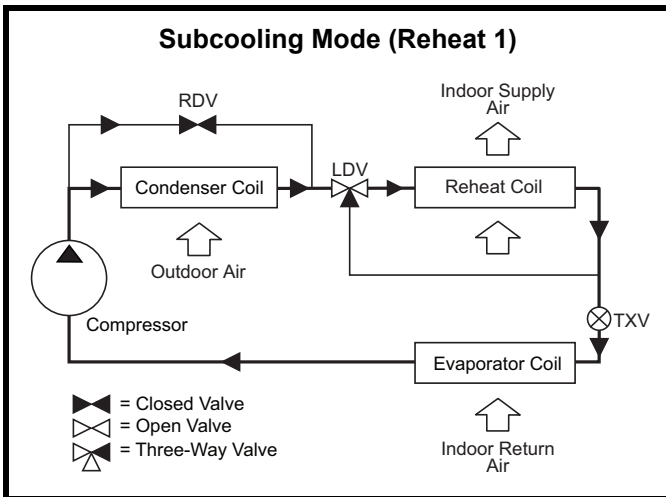
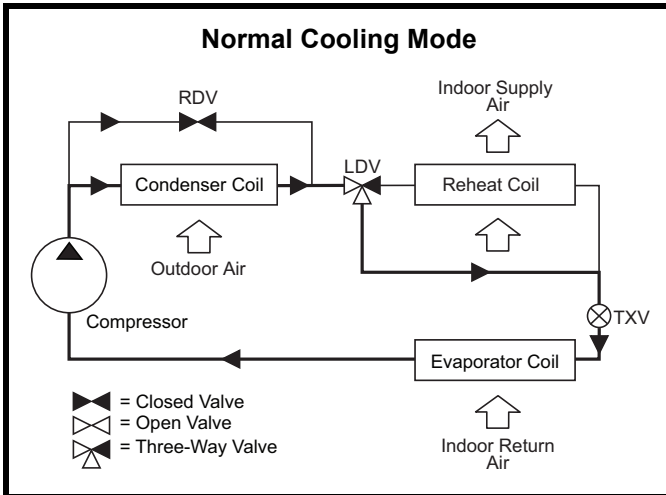

LEGEND

- RDV** — Reheat Discharge Valve
- TWV** — Three-Way Valve
- TXV** — Thermostatic Expansion Valve

Application data

Minimum operating ambient temperature (cooling)

In mechanical cooling mode, your RGF/RAF rooftop unit can safely operate down to an outdoor ambient temperature of 40°F (4°C) (0°F [-18°C] for size 150 models). It is possible to provide cooling at lower outdoor ambient temperatures by using less outside air, economizers, and/or accessory low ambient kits.

Maximum operating ambient temperature (cooling)

The maximum operating ambient temperature for cooling mode is 115°F (46°C) except for size 150 models with 120°F (49°C). While cooling operation above 115°F (46°C) [120°F (49°C) for size 150 models] may be possible, it could cause either a reduction in performance, reliability, or a protective action by the unit's internal safety devices.

Multiple motor and drive packages

Some applications need larger horsepower motors, some need more airflow, and some need both. Regardless of the case, your RGF/RAF expert has a factory installed combination to meet your application. A wide selection of motors are available, factory installed, to handle nearly any application.

Stainless steel heat exchanger (RGF units only)

The stainless steel heat exchanger option provides the tubular heat exchanger be made out of a minimum 20 gauge type 409 stainless steel for applications where the mixed air to the heat exchanger is expected to drop below 45°F (7°C). Stainless steel may be specified on applications where the presence of airborne contaminants require its use (applications such as paper mills) or in area with very high outdoor humidity that may result in severe condensation in the heat exchanger during cooling operation.

Minimum mixed air temperature (heating) (RGF units only)

Using the factory settings, the minimum temperatures for the mixed air (the combined temperature of the warm return air and the cold outdoor air) entering the dimpled, gas heat exchangers are shown in the following table.

Minimum Temperature for Mixed Air Temperature

ALUMINIZED	STAINLESS STEEL
50°F (10°C) Continuous	40°F (4°C) Continuous
45°F (7°C) Intermittent	35°F (2°C) Intermittent

Operating at lower mixed-air temperatures may be possible, if a field-supplied, outdoor air thermostat initiates both heat stages when the temperature is less than the minimum temperatures listed above. Please contact your local representative for assistance.

Minimum and maximum airflow (heating and cooling)

To maintain safe and reliable operation of your rooftop, operate within the heating airflow limits during heating mode and cooling airflow limits during cooling mode. Operating above the max may cause blow-off, undesired airflow noise, or airflow related problems with the rooftop unit. Operating below the min may cause problems with coil freeze-up and unsafe heating operation. Heating and cooling limitations differ when evaluating operating cfm, the minimum value is the HIGHER of the cooling and heating minimum cfm values published on page 8 and the maximum value is the LOWER of the cooling and heating maximum values published on page 8.

Heating-to-cooling changeover

Your unit will automatically change from heating to cooling mode when using a thermostat with an auto-changeover feature.

Airflow

All units are draw-through in cooling mode and blow-through in heating mode.

Outdoor air application strategies

Economizers reduce operating expenses and compressor run time by providing a free source of cooling and a means of ventilation to match application changing needs. In fact, they should be considered for most applications. Also, consider the various economizer control methods and their benefits, as well as sensors required to accomplish your application goals. Please contact your local representative for assistance.

Motor limits, brake horsepower (bhp)

Due to internal design of RGF/RAF units, the air path, and specially designed motors, the full horsepower (maximum continuous bhp) band, as listed in the Fan Performance tables, can be used with the utmost confidence. There is no need for extra safety factors, as RGF/RAF motors are designed and rigorously tested to use the entire, listed bhp range without either nuisance tripping or premature motor failure.

Propane heating (RGF units only)

Propane has different physical qualities than natural gas. As a result, propane requires different fuel to air mixture. To optimize the fuel/air mixture for propane, we sell different burner orifices in an easy to install accessory kit. To select the correct burner orifices or determine the heat capacity for a propane application, use either the selection software, or the unit's service manual.

High altitude heating

High altitudes have less oxygen, which affects the fuel/air mixture in heat exchangers. In order to maintain a proper fuel/air mixture, heat exchangers operating in altitudes above 2000 ft (610 m) require different orifices. To select the correct burner orifices or determine the heat capacity for a high altitude application, use either the selection software, or the unit's service manual.

Application data (cont)

High altitudes have less oxygen, which means heat exchangers need less fuel. The new gas orifices in this field-installed kit make the necessary adjustment for high altitude applications. They restore the optimal fuel to air mixture and maintain healthy combustion on altitudes above 2000 ft (610 m).

NOTE: Typical natural gas heating value ranges from 975 to 1050 Btu/ft³ at sea level nationally. The heating value goes down approximately 1.7% per every thousand feet elevation. Standard factory orifices can typically be used up to 2000 ft (610 m) elevation without any operational issues.

Sizing a rooftop

Bigger is not necessarily better. While an air conditioner needs to have enough capacity to meet the design loads, it does not need excess capacity. In fact, excess capacity typically results in very poor part load performance and humidity control.

Using higher design temperatures than ASHRAE recommends for your location, adding “safety factors” to the calculated load, are all signs of oversizing air conditioners. Oversizing the air conditioner leads to poor humidity control, reduced efficiency, higher utility bills,

larger indoor temperature swings, excessive noise, and increased wear and tear on the air conditioner.

Rather than oversizing an air conditioner, engineers should “right-size” or even slightly “under-size” air conditioners. Correctly sizing an air conditioner controls humidity better; promotes efficiency; reduces utility bills; extends equipment life, and maintains even, comfortable temperatures. Please contact your local representative for assistance.

Low ambient applications

The optional economizer can adequately cool your space by bringing in fresh, cool outside air. In fact, when so equipped, accessory low-ambient kit may not be necessary. In low ambient conditions, unless the outdoor air is excessively humid or contaminated, economizer-based “free cooling” is the preferred less costly and energy conscious method. In low ambient applications where outside air might not be desired (such as contaminated or excessively humid outdoor environments), your RGF/RAF rooftop can operate to ambient temperatures down to 0°F (–18°C) using the recommended accessory low ambient controller.

NOTE: 0°F (–18°C) is standard on size 150 models.

Guide specifications — RGF

Note about this specification:

This specification is in the “Masterformat” as published by the Construction Specification Institute. Please feel free to copy this specification directly into your building spec.

Gas Heat/Electric Cooling Packaged Rooftop

HVAC Guide Specifications

Size Range: **7.5 to 15 Nominal Tons**

Model Number: **RGF090-180**

Part 1 — (23 06 80) Schedules for Decentralized HVAC Equipment

- 1.01 (23 06 80.13) Decentralized Unitary HVAC Equipment Schedule
- A. (23 06 80.13.A.) Rooftop Unit (RTU) Schedule:
1. Schedule is per the project specification requirements.

Part 2 — (23 07 16) HVAC Equipment Insulation

- 2.01 (23 07 16.13) Decentralized, Rooftop Units:
- A. (23 07 16.13.A.) Evaporator Fan Compartment:
1. Interior cabinet surfaces shall be insulated with a minimum 1/2 in. thick, minimum 1 1/2 lb density, flexible fiberglass insulation bonded with a phenolic binder, neoprene coated on the air side.
 2. Insulation and adhesive shall meet NFPA 90A requirements for flame spread and smoke generation.
- B. (23 07 16.13.B.) Gas Heat Compartment:
1. Aluminum foil-faced fiberglass insulation shall be used.
 2. Insulation and adhesive shall meet NFPA 90A requirements for flame spread and smoke generation.

Part 3 — (23 09 13) Instrumentation and Control Devices for HVAC

- 3.01 (23 09 13.23) Sensors and Transmitters
- A. (23 09 13.23.A.) Thermostats:
1. Thermostat must:
 - a. energize both “W” and “G” when calling for heat.
 - b. have capability to energize 1 or 2 stages of cooling, and 2 different stages of heating.
 - c. include capability for occupancy scheduling.

Part 4 — (23 09 33) Electric and Electronic Control System for HVAC

- 4.01 (23 09 33.13) Decentralized, Rooftop Units:
- A. (23 09 33.13.A.) General:
1. Shall be complete with self-contained low-voltage control circuit protected by a resettable circuit breaker on the 24-v transformer side. Transformer shall have 75VA capability.
 2. Shall utilize color-coded wiring.

3. Shall include a Unit Control Board to conveniently and safely provide connection points for vital control functions such as: smoke detectors, phase monitor, gas controller, economizer, thermostat, and low and high pressure switches. Controller shall also provide an intuitive means to adjust the indoor fan speed through a simple switch and pot adjustment design.
 4. The heat exchanger shall be controlled by an integrated gas controller (IGC) microprocessor. See heat exchanger section of this specification.
 5. Unit shall include a minimum of one 8-pin screw terminal connection board for connection of control wiring.
- B. (23 09 33.13.B.) Safeties:
1. Compressor over-temperature, over-current. High internal pressure differential.
 2. Low Pressure Switch
Low pressure switch shall use different color wire than the high pressure switch. The purpose is to assist the installer and service technician to correctly wire and or troubleshoot the rooftop unit.
 3. High Pressure Switch
High pressure switch shall use different color wire than the low pressure switch. The purpose is to assist the installer and service technician to correctly wire and or troubleshoot the rooftop unit.
 4. Mixed Air Auto Reset Temperature Switch:
 - a. All cooling units contain a low return air (or mixed air - depending on unit configuration) temperature switch for compressor protection. The switch prevents compressor operation at mixed air temperatures below 60°F (15°C) to ensure long term reliability but allows continued fan and economizer operation (if in-stalled). The switch will automatically reset when the return/mixed air temperature warms above 65°F (18°C) and will allow compressor operation to continue.
 5. Automatic Reset, Motor Thermal Overload Protector.
 6. Heating section shall be provided with the following minimum protections:
 - a. High temperature limit switches.
 - b. Induced draft motor pressure switch.
 - c. Flame rollout switch.
 - d. Flame proving controls.
 7. A2L Refrigerant Leak Dissipation System (Electromechanical):
 - a. Leak dissipation system shall consist of control board and A2L sensor certified to UL-60335-2-40.

Guide specifications — RGF (cont)

- b. System shall be designed for the life of the unit.
 - c. Dissipation system shall be automatic, ship pre-wired, and require no additional field connections to thermostat to function.
 - d. Refrigerant leak sensor shall be installed in UL-certified location and orientation. Sensor shall be self-correcting and resettable. Single use refrigerant leak sensor shall not be permitted.
 - e. Factory-installed dissipation controller shall use onboard microprocessor and include:
 - 1) Automatic reset after a dissipation event has occurred.
 - 2) Onboard LED with flash code to indicate current unit status and hardware failures.
 - 3) Depressible “Test” button to allow for a system test and recall/reset of leak detection history.
 - 4) 24-v dry contact alarm terminal to allow for external notification of leak detection.
 - f. Dissipation control board shall be accessible via normal maintenance locations and LED shall be visible.
 - g. Dissipation system shall “Fail Safe” per UL requirements.
 - h. Dissipation shall allow smoke and building fire systems to override in case of event.
- 2. Factory assembled, single-piece heating and cooling rooftop unit. Contained within the unit enclosure shall be all factory wiring, piping, controls, and special features required prior to field start-up.
 - 3. Unit shall use R-454B refrigerant.
 - 4. Unit shall be installed in accordance with the manufacturer’s instructions.
 - 5. Unit must be selected and installed in compliance with local, state, and federal codes.
- B. (23 81 19.13.B.) Quality Assurance:
- 1. Unit meets ASHRAE^{®1} 90.1 minimum efficiency requirements.
 - 2. Unit shall be rated in accordance with AHRI Standards 340/360.
 - 3. Unit shall be designed to conform to ASHRAE 15.
 - 4. Unit shall be UL-tested and certified in accordance with ANSI Z21.47 Standards and UL-listed and certified under Canadian standards as a total package for safety requirements.
 - 5. Insulation and adhesive shall meet NFPA 90A requirements for flame spread and smoke generation.
 - 6. Unit casing shall be capable of withstanding 500 hour salt spray exposure per ASTM B117 (scribed specimen).
 - 7. Unit shall be designed in accordance with ISO 9001, and shall be manufactured in a facility registered by ISO 9001:2015.
 - 8. Roof curb shall be designed to conform to NRCA Standards.
 - 9. Unit shall be subjected to a completely automated run test on the assembly line. The data for each unit will be stored at the factory and must be available upon request.
 - 10. Unit shall be designed in accordance with UL Standard 60335-1 and 60335-2-40, including testing to withstand rain. Unit shall be IPX4 rated.
 - 11. Unit shall be constructed to prevent intrusion of snow and tested to prevent snow intrusion into the control box up to 40 mph.
 - 12. Unit shake tested to assurance level 1, ASTM D4169 to ensure shipping reliability.

Part 5 — (23 09 93) Sequence of Operations for HVAC Controls

5.01 (23 09 93.13) Decentralized, Rooftop Units:

- A. (23 09 93.13.A.) INSERT SEQUENCE OF OPERATION

Part 6 — (23 40 13) Panel Air Filters

6.01 (23 40 13.13) Decentralized, Rooftop Units:

- A. (23 40 13.13.A.) Standard Filter Section:
 - 1. Shall consist of factory installed, low velocity, disposable 2 in. thick fiberglass filters of commercially available sizes.
 - 2. Unit shall use only one filter size. Multiple sizes are not acceptable.
 - 3. Filters shall be accessible through an access panel with “no-tool” removal as described in the unit cabinet section of this specification (23 81 19.13.G).

Part 7 — (23 81 19) Self-Contained Air Conditioners

7.01 (23 81 19.13) Small-Capacity Self-Contained Air Conditioners:

- A. (23 81 19.13.A.) General:
 - 1. Outdoor, rooftop mounted, electrically controlled, heating and cooling unit utilizing a fully hermetic scroll compressors for cooling duty and gas combustion for heating duty.

- C. (23 81 19.13.C.) Delivery, Storage, and Handling:
 - 1. Unit shall be stored and handled per manufacturer’s recommendations.
 - 2. Lifted by crane requires either shipping top panel or spreader bars.
 - 3. Unit shall only be stored or positioned in the upright position.

1. Third-party trademarks and logos are the property of their respective owners.

Guide specifications — RGF (cont)

- D. (23 81 19.13.D.) Project Conditions:
1. As specified in the contract.
- E. (23 81 19.13.E.) Operating Characteristics:
1. Unit shall be capable of starting and running at 115°F (46°C) ambient outdoor temperature except 150 size models that are capable of starting and running at 120°F (49°C), meeting maximum load criteria of AHRI Standard 340/360 at ±10% voltage.
 2. Compressor with standard controls shall be capable of operation down to 40°F (4°C) [0°F (–18°C) for size 150 models], ambient outdoor temperatures. Accessory winter start kit is necessary if mechanically cooling at ambient temperatures down to 25°F (–4°C) or 0°F (–18°C).
 3. Unit shall discharge supply air vertically or horizontally as shown on contract drawings.
 4. Unit shall be factory configured for vertical supply and return configurations.
 5. Unit shall be field convertible from vertical to horizontal airflow on all models. No special kit required except on 180 size models that require a Supply Duct Kit field installed for horizontal airflow.
 6. Unit shall be capable of mixed operation: vertical supply with horizontal return or horizontal supply with vertical return.
- F. (23 81 19.13.F.) Electrical Requirements:
1. Main power supply voltage, phase, and frequency must match those required by the manufacturer.
- G. (23 81 19.13.G.) Unit Cabinet:
1. Unit cabinet shall be constructed of galvanized steel, and shall be bonderized and coated with a prepainted baked enamel finish on all externally exposed surfaces.
 2. Unit cabinet exterior paint shall be: film thickness, (dry) 0.003 inches minimum, gloss (per ASTM D523, 60°F/16°C): 60, Hardness: H-2H Pencil hardness.
 3. Evaporator fan compartment interior cabinet insulation shall conform to AHRI Standards 340/360 minimum exterior sweat criteria. Interior surfaces shall be insulated with a minimum 1/2 in. thick, 1 lb density, flexible fiberglass insulation, neoprene coated on the air side. Aluminum foil-faced fiberglass insulation shall be used in the gas heat compartment.
 4. Base of unit shall have a minimum of four locations for thru-the-base gas and electrical connections (factory-installed or field-installed), standard.
 5. Base Rail:
 - a. Unit shall have base rails on a minimum of 2 sides.
 - b. Holes shall be provided in the base rails for rigging shackles to facilitate maneuvering and overhead rigging.
 - c. Holes shall be provided in the base rail for moving the rooftop by fork truck.
 - d. Base rail shall be a minimum of 16 gauge thickness.
6. Condensate Pan and Connections:
- a. Shall be a sloped condensate drain pan made of a corrosion resistant material.
 - b. Shall comply with ASHRAE Standard 62.
 - c. Shall use a 3/4 in. 14 NPT drain connection, possible either through the bottom or side of the drain pan. Connection shall be made per manufacturer's recommendations.
7. Top Panel:
- a. Shall be a single piece top panel on 090-150 models and two piece on 180 size models.
8. Gas Connections:
- a. All gas piping connecting to unit gas valve shall enter the unit cabinet at a single location on side of unit (horizontal plane).
 - b. Thru-the-Base Capability:
 - 1) Standard unit shall have a thru-the-base gas-line location using a raised, embossed portion of the unit basepan.
 - 2) Optional, factory approved, water-tight connection method must be used for thru-the-base gas connections.
 - 3) No basepan penetration, other than those authorized by the manufacturer, is permitted.
9. Electrical Connections:
- a. All unit power wiring shall enter unit cabinet at a single, factory prepared, knockout location.
 - b. Thru-the-Base Capability:
 - 1) Standard unit shall have a thru-the-base electrical location(s) using a raised, embossed portion of the unit basepan.
 - 2) Optional, factory approved, water-tight connection method must be used for thru-the-base electrical connections.
 - 3) No basepan penetration, other than those authorized by the manufacturer, is permitted.
10. Component Access Panels (standard):
- a. Cabinet panels shall be easily removable for servicing.
 - b. Unit shall have one factory installed, tool-less, removable, filter access panel.
 - c. Panels covering control box, indoor fan, indoor fan motor, gas components (where applicable), and compressors shall have molded composite handles.

Guide specifications — RGF (cont)

- d. Handles shall be UV modified, composite. They shall be permanently attached, and recessed into the panel.
 - e. Screws on the vertical portion of all removable access panel shall engage into heat resistant, molded composite collars.
 - f. Collars shall be removable and easily replaceable using manufacturer recommended parts.
- H. (23 81 19.13.H.) Gas Heat:
- 1. General:
 - a. Heat exchanger shall be an induced draft design. Positive pressure heat exchanger designs shall not be allowed.
 - b. Shall incorporate a direct-spark ignition system and redundant main gas valve.
 - c. Gas supply pressure at the inlet to the rooftop unit gas valve must match that required by the manufacturer.
 - 2. The heat exchanger shall be controlled by an integrated gas controller (IGC) microprocessor.
 - a. IGC board shall notify users of fault using an LED (light-emitting diode).
 - b. The LED shall be visible without removing the control box access panel.
 - c. IGC board shall contain algorithms that modify evaporator fan operation to prevent future cycling on high temperature limit switch.
 - d. Unit shall be equipped with anti-cycle protection with one short cycle on unit flame rollout switch or 4 continuous short cycles on the high temperature limit switch. Fault indication shall be made using an LED.
 - 3. Standard Heat Exchanger Construction:
 - a. Heat exchanger shall be of the tubular-section type constructed of a minimum of 20-gauge steel coated with a nominal 1.2 mil aluminum-silicone alloy for corrosion resistance.
 - b. Burners shall be of the in-shot type constructed of aluminum-coated steel.
 - c. Burners shall incorporate orifices for rated heat output up to 2000 ft (610 m) elevation. Additional accessory kits may be required for applications above 2000 ft (610 m) elevation, depending on local gas supply conditions.
 - d. Each heat exchanger tube shall contain multiple dimples for increased heating effectiveness.
 - 4. Optional Stainless Steel Heat Exchanger Construction:
 - a. Use energy saving, direct-spark ignition system.
 - b. Use a redundant main gas valve.
 - c. Burners shall be of the in-shot type constructed of aluminum-coated steel.
 - d. All gas piping shall enter the unit cabinet at a single location on side of unit (horizontal plane).
 - e. The optional stainless steel heat exchanger shall be of the tubular-section type, constructed of a minimum of 20-gauge type 409 stainless steel.
 - f. Type 409 stainless steel shall be used in heat exchanger tubes and vestibule plate.
 - g. Complete stainless steel heat exchanger allows for greater application flexibility.
 - 5. Induced Draft Combustion Motor and Blower:
 - a. Shall be a direct-drive, single inlet, forward-curved centrifugal type.
 - b. Shall be made from steel with a corrosion resistant finish.
 - c. Shall have permanently lubricated sealed bearings.
 - d. Shall have inherent thermal overload protection.
 - e. Shall have an automatic reset feature.
- I. (23 81 19.13.I.) Coils:
- 1. Standard Aluminum Fin-Copper Tube Coils:
 - a. Standard evaporator and condenser coils shall have aluminum lanced plate fins mechanically bonded to seamless internally grooved copper tubes with all joints brazed.
 - b. Evaporator coils shall be leak tested to 150 psig, pressure tested to 450 psig, and qualified to UL 60335-2-40 burst test at 1775 psig.
 - c. Condenser coils shall be leak tested to 150 psig, pressure tested to 650 psig, and qualified to UL 60335-2-40 burst test at 1980 psig.
 - 2. Optional Pre-coated Aluminum-Fin Condenser Coils:
 - a. Shall have a durable epoxy-phenolic coating to provide protection in mildly corrosive coastal environments.
 - b. Coating shall be applied to the aluminum fin stock prior to the fin stamping process to create an inert barrier between the aluminum fin and copper tube.
 - c. Epoxy-phenolic barrier shall minimize galvanic action between dissimilar metals.

Guide specifications — RGF (cont)

- d. Corrosion durability of fin stock shall be confirmed through testing to be no less than 1000 hours salt spray per ASTM B117-90.
 - e. Corrosion durability of fin stock shall be confirmed through testing to have no visible corrosion after 48 hour immersion in a room temperature solution of 5% salt, 1% acetic acid.
 - f. Fin stock coating shall pass 2000 hours of the following: one week exposure in the prohesion chamber followed by one week of accelerated ultraviolet light testing. Prohesion chamber: the solution shall contain 3.5% sodium chloride and 0.35% ammonium sulfate. The exposure cycle is one hour of salt fog application at ambient followed by one hour drying at 95°F (35°C).
3. Optional Copper-Fin Evaporator and Condenser Coils:
- a. Shall be constructed of copper fins mechanically bonded to copper tubes and copper tube sheets.
 - b. Galvanized steel tube sheets shall not be acceptable.
 - c. A polymer strip shall prevent coil assembly from contacting the sheet metal coil pan to minimize potential for galvanic corrosion between coil and pan.
4. Optional E-coated Aluminum-Fin Evaporator and Condenser Coils:
- a. Shall have a flexible epoxy polymer coating uniformly applied to all coil surface areas without material bridging between fins.
 - b. Coating process shall ensure complete coil encapsulation of tubes, fins and headers.
 - c. Color shall be high gloss black with gloss per ASTM D523-89.
 - d. Uniform dry film thickness from 0.8 to 1.2 mil on all surface areas including fin edges.
 - e. Superior hardness characteristics of 2H per ASTM D3363-92A and cross-hatch adhesion of 4B-5B per ASTM D3359-93.
 - f. Impact resistance shall be up to 160 in. lb (ASTM D2794-93).
 - g. Humidity and water immersion resistance shall be up to minimum 1000 and 250 hours respectively (ASTM D2247-92 and ASTM D870-92).
 - h. Corrosion durability shall be confirmed through testing to be no less than 1000 hours salt spray per ASTM B117-90.
- J. (23 81 19.13.J.) Refrigerant Components:
- 1. Refrigerant circuit shall include the following control, safety, and maintenance features:
 - a. Thermostatic Expansion Valve (TXV) shall help provide optimum performance across the entire operating range. Shall contain removable power element to allow change out of power element and bulb without removing the valve body.
 - b. Refrigerant filter drier — Solid core design with pre and post filter service gauge connections for filter diagnostics and maintenance.
 - c. Service gauge connections on suction and discharge lines.
 - d. Pressure gauge access through a specially designed access port in the top panel of the unit.
2. There shall be gauge line access port in the skin of the rooftop.
- a. The gauge access port shall enable maintenance personnel to route their pressure gauge lines.
 - b. This gauge access port shall facilitate correct and accurate condenser pressure readings by enabling the reading with the compressor access panel on.
3. Compressors:
- a. Unit shall use tandem scroll compressor assembly on a single refrigeration circuit with two stages of cooling for efficient comfort cooling operation.
 - b. Evaporator coils shall be a full active design to help better control comfort latent removal and minimize unconditioned bypass air.
 - c. Compressor motors shall be cooled by refrigerant gas passing through motor windings.
 - d. Compressors shall be internally protected from high discharge temperature conditions.
 - e. Compressors shall be protected from an over-temperature and over-amperage conditions by an internal, motor overload device.
 - f. Compressor shall be factory-mounted on rubber grommets.
 - g. Compressor motors shall have internal line break thermal, current overload and high pressure differential protection.
 - h. Crankcase heaters shall not be required for normal operating range, unless required by the manufacturer due to refrigerant charge limits.
- K. (23 81 19.13.K.) Return Air Filter Section:
- 1. Filters access is specified in the unit cabinet section of this specification.
 - 2. Filters shall be held in place by a pivoting filter tray, facilitating easy removal and installation.
 - 3. Shall consist of factory installed, low velocity, throw-away 2 in. thick fiberglass filters.
 - 4. Filters shall be standard, commercially available sizes.
 - 5. Only one size filter per unit is allowed.

Guide specifications — RGF (cont)

L. (23 81 19.13.L.) Evaporator Fan and Motor with X-Vane™ Fan Technology:

1. Direct Drive Evaporator Fan Motor:
 - a. Shall be a ECM motor design.
 - b. Shall be direct drive design for all static options.
 - c. Shall have permanently lubricated bearings.
 - d. Shall have inherent automatic-reset thermal overload protection.
 - e. Shall have slow ramp up to speed capabilities.
 - f. Shall require no fan/motor belts for operation, adjustments and or initial fan speed set up.
 - g. Fan DC voltage set up on Unit Control Board shall eliminate the need of removal of blower access door, required on conventional belt drive systems.
 - h. Shall be internally protected from electrical phase reversal.
2. Evaporator Fan:
 - a. Speed shall be easily set with dedicated selection switch and adjustment pot on unit control board.
 - b. Shall provide 2 stage cooling capacity control, the indoor fan speed is automatically controlled to meet the code-compliant <66% low fan speed and 100% at full fan speed operation.
 - c. Blower fan shall be a Vane Axial fan design with fan assembly secured directly to ECM motor. Additional shafts, belts, pulleys/sheaves, and bearing blocks to drive fan shall not be permitted or necessary.
 - d. Additional variable frequency drive to control fan motor speed shall not be permitted or necessary. All speed control electronics must be onboard fan motor assembly.
 - e. Shall be constructed of a high impact composite material for stator, rotor and air inlet casing.
 - f. Shall be a patented/pending design with a corrosion resistant material.
 - g. Fan assembly design shall be integrated to fan deck, dynamically balanced, and require no additional vibration isolation for normal operation.
 - h. Shall be a slide out design with removal of a few support brackets.
3. Shall include an easily accessible Unit Control Board to conveniently and safely provide connection points for vital control functions such as: smoke detectors, phase monitor, gas controller, economizer, thermostat, and low, high and mixed air temperature switches. Controller shall also provide an intuitive means to adjust

the indoor fan speed through a simple switch and pot adjustment design.

M. (23 81 19.13.M.) Condenser Fans and Motors:

1. Condenser Fan Motors:
 - a. Shall be a totally enclosed motor.
 - b. Shall use permanently lubricated bearings.
 - c. Shall have inherent thermal overload protection with an automatic reset feature.
 - d. Shall use a shaft-down design on all sizes.
2. Condenser Fans:
 - a. Shall be a direct-driven propeller type fan.
 - b. Shall have galvalum blades riveted to steel spider that have corrosion-resistant properties and shall be dynamically balanced.

N. (23 81 19.13.N.) Special Features Options and Accessories:

1. Integrated EconomizerONE Low Leak Rate Models.
 - a. Integrated, gear driven opposing modulating blade design type capable of simultaneous economizer and compressor operation.
 - b. Independent modules for vertical or horizontal return configuration shall be available. Vertical return modules shall be available as a factory installed option.
 - c. Damper blades shall be galvanized steel with composite gears. Plastic or composite blades on intake or return shall not be acceptable.
 - d. Shall include all hardware and controls to provide free cooling with outdoor air when temperature and/or humidity are below setpoints.
 - e. Shall be equipped with gear driven dampers for both the outdoor ventilation air and the return air for positive air stream control.
 - f. Low leak rate shall be equipped with dampers not to exceed 2% leakage at 1 in. wg pressure differential.
 - g. Economizer controller on EconomizerONE models shall be the Siemens POL224 that provides:
 - 1) Combined minimum and DCV maximum damper position potentiometers with compressor staging relay.
 - 2) Optional configuration via WLAN stick and Siemens Climatic™¹ smartphone app for easy setup.
 - 3) Functions with solid-state analog enthalpy or dry bulb changeover control sensing.

1. Third-party trademarks and logos are the property of their respective owners.

Guide specifications — RGF (cont)

- 4) LED indicators for free cooling, sensor, and damper operation.
 - 5) One-line LCD interface screen for setup, configuration and troubleshooting.
 - 6) On-board Fault Detection and Diagnostics (FDD) that senses and alerts when the economizer is not operating properly, per California Title 24, ASHRAE 90.1 and IECC¹.
 - 7) Sensor failure loss of communication identification.
 - 8) Capabilities for use with multiple-speed or single speed indoor fan systems.
 - 9) Digital sensors: Dry bulb and Enthalpy.
 - h. Shall be capable of introducing up to 100% outdoor air.
 - i. Shall be equipped with a barometric relief damper capable of relieving up to 100% return air and contain seals that meet ASHRAE 90.1 requirements.
 - j. Shall be designed to close damper(s) during loss-of-power situations with spring return built into motor.
 - k. Dry bulb outdoor air temperature sensor shall be provided as standard. Enthalpy sensor is also available on factory-installed economizers only. Outdoor air sensor setpoint shall be adjustable and shall range from 40°F to 100°F (4°C to 38°C). Additional sensor options shall be available as accessories.
 - l. The economizer controller shall also provide control of an accessory power exhaust unit function. Factory set at 100%, with a range of 0% to 100%.
 - m. The economizer shall maintain minimum airflow into the building during occupied period and provide design ventilation rate for full occupancy.
 - n. Dampers shall be completely closed when the unit is in the unoccupied mode.
 - o. Economizer controller shall accept a 0 to 10 vdc CO₂ sensor input for IAQ/DCV control. In this mode, dampers shall modulate the outdoor air damper to provide ventilation based on the sensor input.
 - p. Compressor lockout temperature on POL224 control is adjustable from -45°F to 80°F (-43°C to 26°C), set at a factory default of 32°F (0°C).
 - q. Actuator shall be direct coupled to economizer gear. No linkage arms or control rods shall be acceptable.
 - r. Contains LED indicators for free cooling, sensor, and damper operation.
2. Integrated EconomizerONE Ultra Low Leak Rate Models.
 - a. Integrated, gear driven opposing modulating blade design type capable of simultaneous economizer and compressor operation.
 - b. Independent modules for vertical or horizontal return configuration shall be available. Vertical return modules shall be available as a factory installed option.
 - c. Damper blades shall be galvanized steel with composite gears. Plastic or composite blades on intake or return shall not be acceptable.
 - d. Shall include all hardware and controls to provide free cooling with outdoor air when temperature and/or humidity are below setpoints.
 - e. Shall be equipped with gear driven dampers for both the outdoor ventilation air and the return air for positive air stream control.
 - f. Ultra Low Leak design meets California Title 24 section 140.4 and ASHRAE 90.1 requirements for 4 cfm per sq ft on the outside air dampers and 10 cfm per sq ft on the return dampers.
 - g. Economizer controller on EconomizerONE models shall be the Siemens POL224 that provides:
 - 1) One-line LCD interface screen for setup, configuration and troubleshooting.
 - 2) Optional configuration via WLAN stick and Siemens Climatix™ smartphone app for easy setup.
 - 3) On-board Fault Detection and Diagnostics (FDD) that senses and alerts when the economizer is not operating properly, per California Title 24, ASHRAE 90.1 and IECC.
 - 4) Sensor failure loss of communication identification.
 - 5) Capabilities for use with multiple-speed indoor fan systems.
 - 6) Digital sensors: Dry bulb and Enthalpy.
 - h. Shall be capable of introducing up to 100% outdoor air.
 - i. Shall be equipped with a barometric relief damper capable of relieving up to 100% return air and contain seals that meet ASHRAE 90.1 requirements.
 - j. Shall be designed to close damper(s) during loss-of-power situations with spring return built into motor.
 - k. Dry bulb outdoor air temperature sensor shall be provided as standard. Enthalpy sensor is also available on factory-installed

1. Third-party trademarks and logos are the property of their respective owners.

Guide specifications — RGF (cont)

- economizers only. Outdoor air sensor setpoint shall be adjustable and shall range from 40°F to 100°F (4°C to 38°C). Additional sensor options shall be available as accessories.
- l. The economizer controller shall also provide control of an accessory power exhaust unit function. Factory set at 100%, with a range of 0% to 100%.
 - m. The economizer shall maintain minimum airflow into the building during occupied period and provide design ventilation rate for full occupancy.
 - n. Dampers shall be completely closed when the unit is in the unoccupied mode.
 - o. Economizer controller shall accept a 0 to 10 vdc CO₂ sensor input for IAQ/DCV control. In this mode, dampers shall modulate the outdoor air damper to provide ventilation based on the sensor input.
 - p. Compressor lockout temperature on POL224 control is adjustable from -45°F to 80°F (-43°C to 26°C), set at a factory default of 32°F (0°C).
 - q. Actuator shall be direct coupled to economizer gear. No linkage arms or control rods shall be acceptable.
 - r. Contains LED indicators for free cooling, sensor, and damper operation.
3. Wi-Fi/WLAN stick for EconomizerONE POL224 (field-installed):

This item allows use of the Siemens Climatix™ mobile application.
 4. Two-Position Damper (field-installed only):
 - a. Damper shall be a Two-Position Damper. Damper travel shall be from the full closed position to the field adjustable %-open setpoint.
 - b. Damper shall include adjustable damper travel from 25% to 100% (full open).
 - c. Damper shall include single or dual blade, gear driven dampers and actuator motor.
 - d. Actuator shall be direct coupled to damper gear. No linkage arms or control rods shall be acceptable.
 - e. Damper will admit up to 100% outdoor air for applicable rooftop units.
 - f. Damper shall close upon indoor (evaporator) fan shutoff and/or loss of power.
 - g. The damper actuator shall plug into the rooftop unit's wiring harness plug. No hard wiring shall be required.
 - h. Outside air hood shall include aluminum water entrainment filter.
 5. Manual Damper (field-installed only):
 - a. Manual damper package shall consist of damper, air inlet screen, and rain hood which can be preset to admit up to 25 or 50% outdoor air for year round ventilation.
 6. Hot Gas Re-Heat Dehumidification System:

The Hot Gas Re-Heat Dehumidification System shall be factory installed and shall provide greater dehumidification of the occupied space by 2 modes of dehumidification operations in addition to its normal design cooling mode:

 - a. Subcooling mode further sub cools the hot liquid refrigerant leaving the condenser coil when both temperature and humidity in the space are not satisfied.
 - b. Hot gas reheat mode shall mix a portion of the hot gas from the discharge of the compressor with the hot liquid refrigerant leaving the condenser coil to create a 2-phase heat transfer in the system, resulting in a neutral leaving air temperature when only humidity in the space is not satisfied.
 - c. Includes low ambient controller.
 7. Low Ambient Control Package:
 - a. Controller shall control coil head pressure by condenser fan speed modulation or condenser fan cycling and wind baffles.
 - b. Shall consist of solid-state control and condenser coil temperature sensor to maintain condensing temperature between 90°F (32°C) and 110°F (43°C) at outdoor ambient temperatures down to -20°F (-29°C). For full low ambient control range, winter start kit is required.
 8. Propane Gas Conversion Kit:
 - a. Package shall contain all the necessary hardware and instructions to convert a standard natural gas unit for use with liquefied propane, up to 2000 ft (610 m) elevation.
 - b. Additional accessory kits may be required for applications above 2000 ft (610 m) elevation.
 9. Flue Shield (090-150 sizes only):

Flue shield shall provide protection from the hot sides of the gas flue hood.
 10. Condenser Coil Hail Guard Assembly (Factory or field-installed):
 - a. Shall protect against damage from hail.
 - b. Shall be either louvered type.
 11. Unit-Mounted, Non-Fused Disconnect Switch:
 - a. Available on 7.5 to 12.5 ton units with factory equipped FLA of 80 amps or less, or 15 ton units with FLA of 80 amps or less (460/575V) or 100 amps or less (208/230V).

Guide specifications — RGF (cont)

- b. Switch shall be factory installed, internally mounted.
 - c. National Electric Code (NEC) and UL approved non-fused switch shall provide unit power shutoff.
 - d. Shall be accessible from outside the unit.
 - e. Shall provide local shutdown and lockout capability.
 - f. Sized only for the unit as ordered from the factory. Does not accommodate field-installed devices.
12. Convenience Outlet:
- a. Factory Installed Powered Convenience Outlet.
 - 1) Outlet shall be powered from main line power to the rooftop unit.
 - 2) Outlet shall be powered from line side or load side of disconnect by installing contractor, as required by code. If outlet is powered from load side of disconnect, unit electrical ratings shall be UL certified and rated for additional outlet amperage.
 - 3) Outlet shall be factory-installed and internally mounted with easily accessible 115-v female receptacle.
 - 4) Outlet shall include 15 amp GFI receptacles with independent fuse protection.
 - 5) Voltage required to operate convenience outlet shall be provided by a factory installed step-down transformer.
 - 6) Outlet shall be accessible from outside the unit.
 - 7) Outlet shall include a field installed “Wet in Use” cover.
 - b. Factory-Installed Non-Powered Convenience Outlet.
 - 1) Outlet shall be powered from a separate 115/120v power source.
 - 2) A transformer shall not be included.
 - 3) Outlet shall be factory-installed and internally mounted with easily accessible 115-v female receptacle.
 - 4) Outlet shall include 15 amp GFI receptacles with independent fuse protection.
 - 5) Outlet shall be accessible from outside the unit.
 - 6) Outlet shall include a field installed “Wet in Use” cover.
 - c. Field-Installed Non-Powered Convenience Outlet.
 - 1) Outlet shall be powered from a separate 115/120v power source.
 - 2) A transformer shall not be included.
- 3) Outlet shall be field-installed and internally mounted with easily accessible 115-v female receptacle.
 - 4) Outlet shall include 20 amp GFI receptacles. This kit provides a flexible installation method which allows code compliance for height requirements of the GFCI outlet from the finished roof surface as well as the capability to relocate the outlet to a more convenient location.
 - 5) Outlet shall be accessible from outside the unit.
 - 6) Outlet shall include a field installed “Wet in Use” cover.
13. Flue Discharge Deflector:
- a. Flue discharge deflector shall direct unit exhaust vertically instead of horizontally.
 - b. Deflector shall be defined as a “natural draft” device by the National Fuel and Gas (NFG) code.
14. Thru-the-Base Connectors (field-installed only):
- a. Kits shall provide connectors to permit gas and electrical connections to be brought to the unit through the unit basepan.
 - b. Minimum of four connection locations per unit.
15. Supply Duct Cover (size 180 only):
- a. Required when field converting the factory standard vertical duct supply to horizontal duct supply configuration. One required per unit.
16. Propeller Power Exhaust:
- a. Power exhaust shall be used in conjunction with an integrated economizer.
 - b. Independent modules for vertical or horizontal return configurations shall be available.
 - c. Horizontal power exhaust is shall be mounted in return ductwork.
 - d. Power exhaust shall be controlled by economizer controller operation. Exhaust fans shall be energized when dampers open past the 0 to 100% adjustable setpoint on the economizer control.
17. Roof Curbs (Vertical):
- a. Full perimeter roof curb with exhaust capability providing separate air streams for energy recovery from the exhaust air without supply air contamination.
 - b. Formed galvanized steel with wood nailer strip and shall be capable of supporting entire unit weight.
 - c. Permits installation and securing of ductwork to curb prior to mounting unit on the curb.

Guide specifications — RGF (cont)

18. High Altitude Gas Conversion Kit:

Package shall contain all the necessary hardware and instructions to convert a standard natural gas unit to operate from 2000 to 7000 ft (610 to 2134 m) elevation with natural gas or from 0 to 7000 ft (0 to 2134 m) elevation with liquefied propane.
19. Outdoor Air Enthalpy Sensor:

The outdoor air enthalpy sensor shall be used to provide single enthalpy control. When used in conjunction with a return air enthalpy sensor, the unit will provide differential enthalpy control. The sensor allows the unit to determine if outside air is suitable for free cooling.
20. Return Air Enthalpy Sensor:

The return air enthalpy sensor shall be used in conjunction with an outdoor air enthalpy sensor to provide differential enthalpy control.
21. Indoor Air Quality (CO₂) Sensor:
 - a. Shall be able to provide demand ventilation indoor air quality (IAQ) control.
 - b. The IAQ sensor shall be available in duct mount, wall mount, or wall mount with LED display. The setpoint shall have adjustment capability.
22. Smoke Detectors (factory-installed only):
 - a. Shall be a Four-Wire Controller and Detector.
 - b. Shall be environmental compensated with differential sensing for reliable, stable, and drift-free sensitivity.
 - c. Shall use magnet-activated test/reset sensor switches.
 - d. Shall have tool-less connection terminal access.
 - e. Shall have a recessed momentary switch for testing and resetting the detector.
 - f. Controller shall include:
 - 1) One set of normally open alarm initiation contacts for connection to an initiating device circuit on a fire alarm control panel.
 - 2) Two Form-C auxiliary alarm relays for interface with rooftop unit or other equipment.
 - 3) One Form-C supervision (trouble) relay to control the operation of the Trouble LED on a remote test/reset station.
 - 4) Capable of direct connection to 2 individual detector modules.
 - 5) Can be wired to up to 14 other duct smoke detectors for multiple fan shut-down applications.
23. Winter Start Kit:
 - a. Shall contain a bypass device around the low pressure switch.
 - b. Shall be required when mechanical cooling is required down to 40°F (4°C).
 - c. Shall not be required to operate on an economizer when below an outdoor ambient of 40°F (4°C).
24. Time Guard:
 - a. Shall prevent compressor short-cycling by providing a 5-minute delay (±2 minutes) before restarting a compressor after shut-down for any reason.
 - b. One device shall be required per compressor.
25. Disconnect Switch Bracket (size 180 only):
 - a. Provides a pre-engineered and sized mounting bracket for applications requiring a unit mounted fused and non-fused disconnect of greater than 100 amps. Bracket assures that no damage will occur to coils when mounting with screws and other fasteners.
26. Hinged Access Panels:
 - a. Shall provide easy access through integrated quarter turn latches.
 - b. Shall be on major panels of: filter, control box, fan motor, and compressor.
27. Condensate Overflow Switch:

This sensor and related controller monitors the condensate level in the drain pan and shuts down compression operation when overflow conditions occur. It includes:

 - a. Indicator light — solid red (more than 10 seconds on water contact — compressors disabled), blinking red (sensor disconnected).
 - b. 10 second delay to break — eliminates nuisance trips from splashing or waves in pan (sensor needs 10 seconds of constant water contact before tripping).
 - c. Disables the compressors operation when condensate plug is detected, but still allows fans to run for Economizer.
28. 4 in. Return Air Rack (field-installed only):
 - a. Accessory kit is designed to hold 4 in. MERV-8 or MERV-13 filters. Filters not included with kit.
 - b. Shall not be compatible with horizontal units with field-installed economizers.
29. Phase Monitor Control (field-installed only):
 - a. Shall monitor the sequence of 3-phase electrical system to provide a phase reversal protection.

Guide specifications — RGF (cont)

- b. Shall monitor the 3-phase voltage inputs to provide a phase loss protection for the three phase device.
 - c. Will work on either a Delta or Wye power connection.
30. Horn/Strobe Annunciator:
- a. Provides an audible/visual signaling device for use with factory-installed option or field installed accessory smoke detectors.
 - b. Requires installation of a field-supplied 24-v transformer suitable for 4.2 VA (AC) or 3.0 VA (DC) per horn/strobe accessory.
 - c. Requires field-supplied electrical box, North American 1-gang box, 2 in. x 4 in. (51 mm x 102 mm).
- d. Shall have a clear colored lens.
31. High Short Circuit Current Rating (SCCR) Protection:
- a. Factory-installed option shall provide high short circuit current protection to compressor and all indoor and outdoor fan motors rated at 10 kA against high potential fault current situations. (Standard unit comes with 5 kA rating.)
 - b. This option is not available with factory installed Hot Gas Re-Heat system, powered convenience outlet, non-fused disconnect, low ambient controls, phase loss monitor/protection, and 575-v models.

Guide specifications — RAF

Note about this specification:

This specification is in the “Masterformat” as published by the Construction Specification Institute. Please feel free to copy this specification directly into your building spec.

Cooling Only/Electric Heat Packaged Rooftop

HVAC Guide Specifications

Size Range: **7.5 to 15 Nominal Tons**

Model Number: **RAF090-180**

Part 1 — (23 06 80) Schedules for Decentralized HVAC Equipment

1.01 (23 06 80.13) Decentralized Unitary HVAC Equipment Schedule:

- A. (23 06 80.13.A.) Rooftop Unit (RTU) Schedule:
1. Schedule is per the project specification requirements.

Part 2 — (23 07 16) HVAC Equipment Insulation

2.01 (23 07 16.13) Decentralized, Rooftop Units:

- A. (23 07 16.13.A.) Evaporator Fan Compartment:
1. Interior cabinet surfaces shall be insulated with a minimum 1/2 in. thick, minimum 1 1/2 lb density, flexible fiberglass insulation bonded with a phenolic binder, neoprene coated on the air side.
 2. Insulation and adhesive shall meet NFPA 90A requirements for flame spread and smoke generation.
- B. (23 07 16.13.B.) Electric Heat Compartment:
1. Aluminum foil-faced fiberglass insulation shall be used.
 2. Insulation and adhesive shall meet NFPA 90A requirements for flame spread and smoke generation.

Part 3 — (23 09 13) Instrumentation and Control Devices for HVAC

3.01 (23 09 13.23) Sensors and Transmitters:

- A. (23 09 13.23.A.) Thermostats:
1. Thermostat must:
 - a. energize both “W” and “G” when calling for heat.
 - b. have capability to energize 1 or 2 stages of cooling, and 2 different stages of heating.
 - c. include capability for occupancy scheduling.

Part 4 — (23 09 33) Electric and Electronic Control System for HVAC

4.01 (23 09 33.13) Decentralized, Rooftop Units:

- A. (23 09 33.13.A.) General:
1. Shall be complete with self-contained low-voltage control circuit protected by a resettable circuit breaker on the 24-v transformer side. Transformer shall have 75VA capability.
 2. Shall utilize color-coded wiring.

3. Shall include a Unit Control Board to conveniently and safely provide connection points for vital control functions such as: smoke detectors, phase monitor, economizer, thermostat, and low and high pressure switches. Controller shall also provide an intuitive means to adjust the indoor fan speed through a simple switch and pot adjustment design.
 4. Unit shall include a minimum of one 8-pin screw terminal connection board for connection of control wiring.
- B. (23 09 33.13.B.) Safeties:
1. Compressor over-temperature, over-current. High internal pressure differential.
 2. Low Pressure Switch
Low pressure switch shall use different color wire than the high pressure switch. The purpose is to assist the installer and service technician to correctly wire and or troubleshoot the rooftop unit.
 3. High Pressure Switch
High pressure switch shall use different color wire than the low pressure switch. The purpose is to assist the installer and service technician to correctly wire and or troubleshoot the rooftop unit.
 4. Mixed Air Auto Reset Temperature Switch
All cooling units contain a low return air (or mixed air - depending on unit configuration) temperature switch for compressor protection. The switch prevents compressor operation at mixed air temperatures below 60°F (15°C) to ensure long term reliability but allows continued fan and economizer operation (if installed). The switch will automatically reset when the return/mixed air temperature warms above 65°F (18°C) and will allow compressor operation to continue.
 5. Heating section shall be provided with the following minimum protections:
 - a. High temperature limit switches.
 6. A2L Refrigerant Leak Dissipation System (Electromechanical):
 - a. Leak dissipation system shall consist of control board and A2L sensor certified to UL-60335-2-40.
 - b. System shall be designed for the life of the unit.
 - c. Dissipation system shall be automatic, ship pre-wired, and require no additional field connections to thermostat to function.
 - d. Refrigerant leak sensor shall be installed in UL-certified location and orientation. Sensor shall be self-correcting and resettable. Single use refrigerant leak sensor shall not be permitted.

Guide specifications — RAF (cont)

- e. Factory-installed dissipation controller shall use onboard microprocessor and include:
 - 1) Automatic reset after a dissipation event has occurred.
 - 2) Onboard LED with flash code to indicate current unit status and hardware failures.
 - 3) Depressible “Test” button to allow for a system test and recall/reset of leak detection history.
 - 4) 24-v dry contact alarm terminal to allow for external notification of leak detection.
- f. Dissipation control board shall be accessible via normal maintenance locations and LED shall be visible.
- g. Dissipation system shall “Fail Safe” per UL requirements.
- h. Dissipation shall allow smoke and building fire systems to override in case of event.

Part 5 — (23 09 93) Sequence of Operations for HVAC Controls

5.01 (23 09 93.13) Decentralized, Rooftop Units:

- A. (23 09 93.13.A.) INSERT SEQUENCE OF OPERATION

Part 6 — (23 40 13) Panel Air Filters

6.01 (23 40 13.13) Decentralized, Rooftop Units:

- A. (23 40 13.13.A.) Standard Filter Section:
 - 1. Shall consist of factory installed, low velocity, disposable 2 in. thick fiberglass filters of commercially available sizes.
 - 2. Unit shall use only one filter size. Multiple sizes are not acceptable.
 - 3. Filters shall be accessible through an access panel with “no-tool” removal as described in the unit cabinet section of this specification (23 81 19.13.G).

Part 7 — (23 81 19) Self-Contained Air Conditioners

7.01 (23 81 19.13) Small-Capacity Self-Contained Air Conditioners:

- A. (23 81 19.13.A.) General:
 - 1. Outdoor, rooftop mounted, electrically controlled, cooling unit utilizing a fully hermetic scroll compressor(s) for cooling duty.
 - 2. Factory assembled, single-piece cooling rooftop unit. Contained within the unit enclosure shall be all factory wiring, piping, controls, and special features required prior to field start-up.
 - 3. Unit shall use R-454B refrigerant.
 - 4. Unit shall be installed in accordance with the manufacturer’s instructions.
 - 5. Unit must be selected and installed in compliance with local, state, and federal codes.

B. (23 81 19.13.B.) Quality Assurance:

- 1. Unit meets ASHRAE®¹ 90.1 minimum efficiency requirements.
- 2. Unit shall be rated in accordance with AHRI Standards 340/360.
- 3. Unit shall be designed to conform to ASHRAE 15.
- 4. Unit shall be UL-tested and certified in accordance with ANSI Z21.47 Standards and UL-listed and certified under Canadian standards as a total package for safety requirements.
- 5. Insulation and adhesive shall meet NFPA 90A requirements for flame spread and smoke generation.
- 6. Unit casing shall be capable of withstanding 500 hour salt spray exposure per ASTM B117 (scribed specimen).
- 7. Unit shall be designed in accordance with ISO 9001, and shall be manufactured in a facility registered by ISO 9001:2015.
- 8. Roof curb shall be designed to conform to NRCA Standards.
- 9. Unit shall be subjected to a completely automated run test on the assembly line. The data for each unit will be stored at the factory, and must be available upon request.
- 10. Unit shall be designed in accordance with UL Standard 60335-1 and 60335-2-40, including testing to with-stand rain. Unit shall be IPX4 rated.
- 11. Unit shall be constructed to prevent intrusion of snow and tested to prevent snow intrusion into the control box up to 40 mph.
- 12. Unit shake tested to assurance level 1, ASTM D4169 to ensure shipping reliability.

C. (23 81 19.13.C.) Delivery, Storage, and Handling:

- 1. Unit shall be stored and handled per manufacturer’s recommendations.
- 2. Lifted by crane requires either shipping top panel or spreader bars.
- 3. Unit shall only be stored or positioned in the upright position.

D. (23 81 19.13.D.) Project Conditions:

- 1. As specified in the contract.

E. (23 81 19.13.E.) Operating Characteristics:

- 1. Unit shall be capable of starting and running at 115°F (46°C) ambient outdoor temperature except 150 size models that are capable of starting and running at 120°F (49°C), meeting maximum load criteria of AHRI Standard 340/360 at ±10% voltage.

1. Third-party trademarks and logos are the property of their respective owners.

Guide specifications — RAF (cont)

2. Compressor with standard controls shall be capable of operation down to 40°F (4°C) [0°F (–18°C) for size 150 models], ambient outdoor temperatures. Accessory winter start kit is necessary if mechanically cooling at ambient temperatures down to 25°F (–4°C) or 0°F (–18°C).
 3. Unit shall discharge supply air vertically or horizontally as shown on contract drawings.
 4. Unit shall be factory configured for vertical supply and return configurations.
 5. Unit shall be field convertible from vertical to horizontal airflow on all models. No special kit required except on 180 size models that requires a Supply Duct Kit field installation for horizontal airflow.
 6. Unit shall be capable of mixed operation: vertical supply with horizontal return or horizontal supply with vertical return.
- F. (23 81 19.13.F.) Electrical Requirements:
1. Main power supply voltage, phase, and frequency must match those required by the manufacturer.
- G. (23 81 19.13.G.) Unit Cabinet:
1. Unit cabinet shall be constructed of galvanized steel, and shall be bonderized and coated with a prepainted baked enamel finish on all externally exposed surfaces.
 2. Unit cabinet exterior paint shall be: film thickness, (dry) 0.003 in. minimum, gloss (per ASTM D523, 60°F/16°C): 60, Hardness: H-2H Pencil hardness.
 3. Evaporator fan compartment interior cabinet insulation shall conform to AHRI Standards 340/360 minimum exterior sweat criteria. Interior surfaces shall be insulated with a minimum 1/2 in. thick, 1 lb density, flexible fiberglass insulation, neoprene coated on the air side. Aluminum foil-faced fiberglass insulation shall be used in the heat compartment.
 4. Base of unit shall have a minimum of four locations for thru-the-base gas and electrical connections (factory-installed or field-installed), standard.
 5. Base Rail:
 - a. Unit shall have base rails on a minimum of 2 sides.
 - b. Holes shall be provided in the base rails for rigging shackles to facilitate maneuvering and overhead rigging.
 - c. Holes shall be provided in the base rail for moving the rooftop by fork truck.
 - d. Base rail shall be a minimum of 16 gauge thickness.
 6. Condensate Pan and Connections:
 - a. Shall be a sloped condensate drain pan made of a corrosion resistant material.
 - b. Shall comply with ASHRAE Standard 62.
 - c. Shall use a 3/4 in. 14 NPT drain connection, possible either through the bottom or side of the drain pan. Connection shall be made per manufacturer's recommendations.
7. Top Panel:
 - a. Shall be a single piece top panel on 090-150 models and two piece on 180 size models.
8. Electrical Connections:
 - a. All unit power wiring shall enter unit cabinet at a single, factory prepared, knockout location.
 - b. Thru-the-base capability.
 - 1) Standard unit shall have a thru-the-base electrical location(s) using a raised, embossed portion of the unit basepan.
 - 2) Optional, factory approved, water-tight connection method must be used for thru-the-base electrical connections.
 - 3) No basepan penetration, other than those authorized by the manufacturer, is permitted.
9. Component Access Panels (standard):
 - a. Cabinet panels shall be easily removable for servicing.
 - b. Unit shall have one factory installed, tool-less, removable, filter access panel.
 - c. Panels covering control box, indoor fan, indoor fan motor, gas components (where applicable), and compressors shall have molded composite handles.
 - d. Handles shall be UV modified, composite. They shall be permanently attached, and recessed into the panel.
 - e. Screws on the vertical portion of all removable access panel shall engage into heat resistant, molded composite collars.
 - f. Collars shall be removable and easily replaceable using manufacturer recommended parts.
- H. (23 81 19.13.H.) Coils:
1. Standard Aluminum Fin-Copper Tube Coils:
 - a. Standard evaporator and condenser coils shall have aluminum lanced plate fins mechanically bonded to seamless internally grooved copper tubes with all joints brazed.
 - b. Evaporator coils shall be leak tested to 150 psig, pressure tested to 450 psig, and qualified to UL 60335-2-40 burst test at 1775 psig.
 - c. Condenser coils shall be leak tested to 150 psig, pressure tested to 650 psig, and qualified to UL 60335-2-40 burst test at 1980 psig.

Guide specifications — RAF (cont)

2. Optional Pre-coated Aluminum-Fin Condenser Coils:
 - a. Shall have a durable epoxy-phenolic coating to provide protection in mildly corrosive coastal environments.
 - b. Coating shall be applied to the aluminum fin stock prior to the fin stamping process to create an inert barrier between the aluminum fin and copper tube.
 - c. Epoxy-phenolic barrier shall minimize galvanic action between dissimilar metals.
 - d. Corrosion durability of fin stock shall be confirmed through testing to be no less than 1000 hours salt spray per ASTM B117-90.
 - e. Corrosion durability of fin stock shall be confirmed through testing to have no visible corrosion after 48 hour immersion in a room temperature solution of 5% salt, 1% acetic acid.
 - f. Fin stock coating shall pass 2000 hours of the following: one week exposure in the prohesion chamber followed by one week of accelerated ultraviolet light testing. Prohesion chamber: the solution shall contain 3.5% sodium chloride and 0.35% ammonium sulfate. The exposure cycle is one hour of salt fog application at ambient followed by one hour drying at 95°F (35°C).
3. Optional Copper-Fin Evaporator and Condenser Coils:
 - a. Shall be constructed of copper fins mechanically bonded to copper tubes and copper tube sheets.
 - b. Galvanized steel tube sheets shall not be acceptable.
 - c. A polymer strip shall prevent coil assembly from contacting the sheet metal coil pan to minimize potential for galvanic corrosion between coil and pan.
4. Optional E-coated Aluminum-Fin Evaporator and Condenser Coils:
 - a. Shall have a flexible epoxy polymer coating uniformly applied to all coil surface areas without material bridging between fins.
 - b. Coating process shall ensure complete coil encapsulation of tubes, fins and headers.
 - c. Color shall be high gloss black with gloss per ASTM D523-89.
 - d. Uniform dry film thickness from 0.8 to 1.2 mil on all surface areas including fin edges.
 - e. Superior hardness characteristics of 2H per ASTM D3363-92A and cross-hatch adhesion of 4B-5B per ASTM D3359-93.
 - f. Impact resistance shall be up to 160 in.-lb (ASTM D2794-93).
- g. Humidity and water immersion resistance shall be up to minimum 1000 and 250 hours respectively (ASTM D2247-92 and ASTM D870-92).
- h. Corrosion durability shall be confirmed through testing to be no less than 1000 hours salt spray per ASTM B117-90.
- I. (23 81 19.13.I.) Refrigerant Components:
 1. Refrigerant circuit shall include the following control, safety, and maintenance features:
 - a. Thermostatic Expansion Valve (TXV) shall help provide optimum performance across the entire operating range. Shall contain removable power element to allow change out of power element and bulb without removing the valve body.
 - b. Refrigerant filter drier — Solid core design with pre and post filter service gauge connections for filter diagnostics and maintenance.
 - c. Service gauge connections on suction and discharge lines.
 - d. Pressure gauge access through a specially designed access port in the top panel of the unit.
 2. There shall be gauge line access port in the skin of the rooftop.
 - a. The gauge access port shall enable maintenance personnel to route their pressure gauge lines.
 - b. This gauge access port shall facilitate correct and accurate condenser pressure readings by enabling the reading with the compressor access panel on.
 3. Compressors:
 - a. Unit shall use tandem scroll compressor assembly on a single refrigeration circuit with two stages of cooling for efficient comfort cooling operation.
 - b. Evaporator coils shall be a full active design to help better control comfort latent removal.
 - c. Compressor motors shall be cooled by refrigerant gas passing through motor windings.
 - d. Compressors shall be internally protected from high discharge temperature conditions.
 - e. Compressors shall be protected from an over-temperature and over-ampereage conditions by an internal, motor overload device.
 - f. Compressor shall be factory mounted on rubber grommets.
 - g. Compressor motors shall have internal line break thermal, current overload and high pressure differential protection.

Guide specifications — RAF (cont)

- h. Crankcase heaters shall not be required for normal operating range, unless required by compressor manufacturer due to refrigerant charge limits.
- J. (23 81 19.13.J.) Filter Section:
 - 1. Filters access is specified in the unit cabinet section of this specification.
 - 2. Filters shall be held in place by a pivoting filter tray, facilitating easy removal and installation.
 - 3. Shall consist of factory installed, low velocity, throw-away 2 in. thick fiberglass filters.
 - 4. Filters shall be standard, commercially available sizes.
 - 5. Only one size filter per unit is allowed.
- K. (23 81 19.13.K.) Evaporator Fan and Motor with X-Vane™ Fan Technology:
 - 1. Direct Drive Evaporator Fan Motor:
 - a. Shall be a ECM motor design.
 - b. Shall be direct drive design for all static options.
 - c. Shall have permanently lubricated bearings.
 - d. Shall have inherent automatic-reset thermal overload protection.
 - e. Shall have slow ramp up to speed capabilities.
 - f. Shall require no fan/motor belts for operation, adjustments and or initial fan speed set up.
 - g. Fan DC voltage set up on Unit Control Board shall eliminate the need of removal of blower access door, required on conventional belt drive systems.
 - h. Shall be internally protected from electrical phase reversal and loss.
 - 2. Evaporator Fan:
 - a. Shall be easily set with dedicated selection switch and adjustment pot on unit control board.
 - b. Shall provide 2-stage cooling capacity control, the indoor fan speed is automatically controlled to meet the code-compliant <66% low fan speed and 100% at full fan speed operation.
 - c. Blower fan shall be a Vane Axial fan design with fan assembly secured directly to ECM motor. Additional shafts, belts, pulleys/sheaves, and bearing blocks to drive fan shall not be permitted or necessary.
 - d. Additional variable frequency drive to control fan motor speed shall not be permitted or necessary. All speed control electronics must be onboard fan motor assembly.
 - e. Shall be constructed of a cast aluminum stator and high impact composite material on stator, rotor and air inlet casing.
 - f. Shall be a patented/pending design with corrosion resistant material.
 - g. Fan assembly design shall be integrated to fan deck, dynamically balanced, and require no additional vibration isolation for normal operation.
 - h. Shall have slow ramp up to speed capabilities to help reduce sound and comfort issues typically associated with single speed belt drive systems.
 - i. Shall be a slide out design with removal of a few support brackets.
- 3. Shall include an easily accessible Unit Control Board to conveniently and safely provide connection points for vital control functions such as: smoke detectors, phase monitor, gas controller, economizer, thermostat, and low, high and mixed air temperature switches. Controller shall also provide an intuitive means to adjust the indoor fan speed through a simple switch and pot adjustment design.
- L. (23 81 19.13.L.) Condenser Fans and Motors:
 - 1. Condenser Fan Motors:
 - a. Shall be a totally enclosed motor.
 - b. Shall use permanently lubricated bearings.
 - c. Shall have inherent thermal overload protection with an automatic reset feature.
 - d. Shall use a shaft-down design on all sizes.
 - 2. Condenser Fans:
 - a. Shall be a direct-driven propeller type fan.
 - b. Shall have galvalum blades riveted to steel spider that have corrosion-resistant properties and shall be dynamically balanced.
- M. (23 81 19.13.M.) Special Features Options and Accessories:
 - 1. Integrated EconomizerONE Low Leak Rate Models.
 - a. Integrated, gear driven opposing modulating blade design type capable of simultaneous economizer and compressor operation.
 - b. Independent modules for vertical or horizontal return configuration shall be available. Vertical return modules shall be available as a factory installed option.
 - c. Damper blades shall be galvanized steel with composite gears. Plastic or composite blades on intake or return shall not be acceptable.
 - d. Shall include all hardware and controls to provide free cooling with outdoor air when temperature and/or humidity are below setpoints.
 - e. Shall be equipped with gear driven dampers for both the outdoor ventilation air and the return air for positive air stream control.

Guide specifications — RAF (cont)

- f. Low leak rate shall be equipped with dampers not to exceed 2% leakage at 1 in. wg pressure differential.
 - g. Economizer controller on EconomizerONE models shall be the Siemens POL224 that provides:
 - 1) Combined minimum and DCV maximum damper position potentiometers with compressor staging relay.
 - 2) Optional configuration via WLAN stick and Siemens Climatic™¹ smartphone app for easy setup.
 - 3) Functions with solid-state analog enthalpy or dry bulb changeover control sensing.
 - 4) LED indicators for free cooling, sensor, and damper operation.
 - 5) One-line LCD interface screen for setup, configuration and troubleshooting.
 - 6) On-board Fault Detection and Diagnostics (FDD) that senses and alerts when the economizer is not operating properly, per California Title 24, ASHRAE 90.1 and IECC®¹.
 - 7) Sensor failure loss of communication identification.
 - 8) Capabilities for use with multiple-speed or single speed indoor fan systems.
 - 9) Digital sensors: Dry bulb and Enthalpy.
 - h. Shall be capable of introducing up to 100% outdoor air.
 - i. Shall be equipped with a barometric relief damper capable of relieving up to 100% return air and contain seals that meet ASHRAE 90.1 requirements.
 - j. Shall be designed to close damper(s) during loss-of-power situations with spring return built into motor.
 - k. Dry bulb outdoor air temperature sensor shall be provided as standard. Enthalpy sensor is also available on factory-installed economizers only. Outdoor air sensor setpoint shall be adjustable and shall range from 40°F to 100°F (4°C to 38°C). Additional sensor options shall be available as accessories.
 - l. The economizer controller shall also provide control of an accessory power exhaust unit function. Factory set at 100%, with a range of 0% to 100%.
 - m. The economizer shall maintain minimum airflow into the building during occupied period and provide design ventilation rate for full occupancy.
 - n. Dampers shall be completely closed when the unit is in the unoccupied mode.
 - o. Economizer controller shall accept a 0 to 10 vdc CO₂ sensor input for IAQ/DCV control. In this mode, dampers shall modulate the outdoor air damper to provide ventilation based on the sensor input.
 - p. Compressor lockout temperature on POL224 control is adjustable from -45°F to 80°F (-43°C to 26°C), set at a factory default of 32°F (0°C).
 - q. Actuator shall be direct coupled to economizer gear. No linkage arms or control rods shall be acceptable.
 - r. Contains LED indicators for free cooling, sensor, and damper operation.
2. Integrated EconomizerONE Ultra Low Leak Rate Models.
- a. Integrated, gear driven opposing modulating blade design type capable of simultaneous economizer and compressor operation.
 - b. Independent modules for vertical or horizontal return configuration shall be available. Vertical return modules shall be available as a factory installed option.
 - c. Damper blades shall be galvanized steel with composite gears. Plastic or composite blades on intake or return shall not be acceptable.
 - d. Shall include all hardware and controls to provide free cooling with outdoor air when temperature and/or humidity are below setpoints.
 - e. Shall be equipped with gear driven dampers for both the outdoor ventilation air and the return air for positive air stream control.
 - f. Ultra Low Leak design meets California Title 24 section 140.4 and ASHRAE 90.1 requirements for 4 cfm per sq ft on the outside air dampers and 10 cfm per sq ft on the return dampers.
 - g. Economizer controller on EconomizerONE models shall be the Siemens POL224 that provides:
 - 1) One-line LCD interface screen for setup, configuration and troubleshooting.
 - 2) Optional configuration via WLAN stick and Siemens Climatic™¹ smartphone app for easy setup.
 - 3) On-board Fault Detection and Diagnostics (FDD) that senses and alerts when the economizer is not operating properly, per California Title 24, ASHRAE 90.1 and IECC.
 - 4) Sensor failure loss of communication identification.

1. Third-party trademarks and logos are the property of their respective owners.

Guide specifications — RAF (cont)

- 5) Capabilities for use with multiple-speed indoor fan systems.
 - 6) Digital sensors: Dry bulb and Enthalpy.
 - h. Shall be capable of introducing up to 100% outdoor air.
 - i. Shall be equipped with a barometric relief damper capable of relieving up to 100% return air and contain seals that meet ASHRAE 90.1 requirements.
 - j. Shall be designed to close damper(s) during loss-of-power situations with spring return built into motor.
 - k. Dry bulb outdoor air temperature sensor shall be provided as standard. Enthalpy sensor is also available on factory-installed economizers only. Outdoor air sensor setpoint shall be adjustable and shall range from 40°F to 100°F (4°C to 38°C). Additional sensor options shall be available as accessories.
 - l. The economizer controller shall also provide control of an accessory power exhaust unit function. Factory set at 100%, with a range of 0% to 100%.
 - m. The economizer shall maintain minimum airflow into the building during occupied period and provide design ventilation rate for full occupancy.
 - n. Dampers shall be completely closed when the unit is in the unoccupied mode.
 - o. Economizer controller shall accept a 0 to 10 vdc CO₂ sensor input for IAQ/DCV control. In this mode, dampers shall modulate the outdoor air damper to provide ventilation based on the sensor input.
 - p. Compressor lockout temperature on POL224 control is adjustable from -45°F to 80°F (-43°C to 26°C), set at a factory default of 32°F (0°C).
 - q. Actuator shall be direct coupled to economizer gear. No linkage arms or control rods shall be acceptable.
 - r. Contains LED indicators for free cooling, sensor, and damper operation.
3. Wi-Fi/WLAN stick for EconomizerONE POL224 (field-installed):

This item allows use of the Siemens Climatix™ mobile application.
 4. Two-Position Damper (field-installed only):
 - a. Damper shall be a Two-Position Damper. Damper travel shall be from the full closed position to the field adjustable %-open setpoint.
 - b. Damper shall include adjustable damper travel from 25% to 100% (full open).
 - c. Damper shall include single or dual blade, gear driven dampers and actuator motor.
 - d. Actuator shall be direct coupled to damper gear. No linkage arms or control rods shall be acceptable.
 - e. Damper will admit up to 100% outdoor air for applicable rooftop units.
 - f. Damper shall close upon indoor (evaporator) fan shutoff and/or loss of power.
 - g. The damper actuator shall plug into the rooftop unit's wiring harness plug. No hard wiring shall be required.
 - h. Outside air hood shall include aluminum water entrainment filter.
 5. Manual Damper (field-installed only):

Manual damper package shall consist of damper, air inlet screen, and rain hood which can be preset to admit up to 25% or 50% outdoor air for year round ventilation.
 6. Hot Gas Re-Heat Dehumidification System:

The Hot Gas Re-Heat Dehumidification System shall be factory installed and shall provide greater dehumidification of the occupied space by two modes of dehumidification operations in addition to its normal design cooling mode:

 - a. Subcooling mode further sub cools the hot liquid refrigerant leaving the condenser coil when both temperature and humidity in the space are not satisfied.
 - b. Hot gas reheat mode shall mix a portion of the hot gas from the discharge of the compressor with the hot liquid refrigerant leaving the condenser coil to create a 2-phase heat transfer in the system, resulting in a neutral leaving air temperature when only humidity in the space is not satisfied.
 - c. Includes low ambient controller.
 7. Low Ambient Control Package:
 - a. Controller shall control coil head pressure by condenser fan speed modulation or condenser fan cycling and wind baffles.
 - b. Shall consist of solid-state control and condenser coil temperature sensor to maintain condensing temperature between 90°F (32°C) and 110°F (43°C) at outdoor ambient temperatures down to 0°F (-18°C).
 8. Condenser Coil Hail Guard Assembly (factory or field-installed):
 - a. Shall protect against damage from hail.
 - b. Shall be louvered type.
 9. Unit-Mounted, Non-Fused Disconnect Switch:
 - a. Available on 7.5 to 12.5 ton units with factory equipped FLA of 80 amps or less, or 15 ton units with FLA of 100 amps or less (460/575V) or 200 amps or less (208/230V).
 - b. Switch shall be factory installed, internally mounted.

Guide specifications — RAF (cont)

- c. National Electric Code (NEC) and UL approved non-fused switch shall provide unit power shutoff.
 - d. Shall be accessible from outside the unit.
 - e. Shall provide local shutdown and lockout capability.
 - f. Sized only for the unit as ordered from the factory. Does not accommodate field-installed devices.
10. Convenience Outlet:
- a. Factory-Installed Powered Convenience Outlet.
 - 1) Outlet shall be powered from main line power to the rooftop unit.
 - 2) Outlet shall be powered from line side or load side of disconnect by installing contractor, as required by code. If outlet is powered from load side of disconnect, unit electrical ratings shall be UL certified and rated for additional outlet amperage.
 - 3) Outlet shall be factory-installed and internally mounted with easily accessible 115-v female receptacle.
 - 4) Outlet shall include 15 amp GFI receptacles with independent fuse protection.
 - 5) Voltage required to operate convenience outlet shall be provided by a factory installed step-down transformer.
 - 6) Outlet shall be accessible from outside the unit.
 - 7) Outlet shall include a field installed "Wet in Use" cover.
 - b. Factory-Installed Non-Powered Convenience Outlet.
 - 1) Outlet shall be powered from a separate 115/120v power source.
 - 2) A transformer shall not be included.
 - 3) Outlet shall be factory-installed and internally mounted with easily accessible 115-v female receptacle.
 - 4) Outlet shall include 15 amp GFI receptacles with independent fuse protection.
 - 5) Outlet shall be accessible from outside the unit.
 - 6) Outlet shall include a field installed "Wet in Use" cover.
 - c. Field-Installed Non-Powered Convenience Outlet.
 - 1) Outlet shall be powered from a separate 115/120v power source.
 - 2) A transformer shall not be included.
 - 3) Outlet shall be field-installed and internally mounted with easily accessible 115-v female receptacle.
- 4) Outlet shall include 20 amp GFI receptacles. This kit provides a flexible installation method which allows code compliance for height requirements of the GFCI outlet from the finished roof surface as well as the capability to relocate the outlet to a more convenient location.
 - 5) Outlet shall be accessible from outside the unit.
 - 6) Outlet shall include a field installed "Wet in Use" cover.
11. Thru-the-Base Connectors (field-installed only):
- a. Kits shall provide connectors to permit gas and electrical connections to be brought to the unit through the unit basepan.
 - b. Minimum of four connection locations per unit.
12. Supply Duct Cover (size 180 only):
- a. Required when field converting the factory standard vertical duct supply to horizontal duct supply configuration. One required per unit.
13. Propeller Power Exhaust:
- a. Power exhaust shall be used in conjunction with an integrated economizer.
 - b. Independent modules for vertical or horizontal return configurations shall be available.
 - c. Horizontal power exhaust is shall be mounted in return ductwork.
 - d. Power exhaust shall be controlled by economizer controller operation. Exhaust fans shall be energized when dampers open past the 0 to 100% adjustable setpoint on the economizer control.
14. Roof Curbs (Vertical):
- a. Full perimeter roof curb with exhaust capability providing separate air streams for energy recovery from the exhaust air without supply air contamination.
 - b. Formed galvanized steel with wood nailer strip and shall be capable of supporting entire unit weight.
 - c. Permits installation and securing of ductwork to curb prior to mounting unit on the curb.
15. Outdoor Air Enthalpy Sensor:
- The outdoor air enthalpy sensor shall be used to provide single enthalpy control. When used in conjunction with a return air enthalpy sensor, the unit will provide differential enthalpy control. The sensor allows the unit to determine if outside air is suitable for free cooling.

Guide specifications — RAF (cont)

16. Return Air Enthalpy Sensor:

The return air enthalpy sensor shall be used in conjunction with an outdoor air enthalpy sensor to provide differential enthalpy control.
17. Indoor Air Quality (CO₂) Sensor:
 - a. Shall be able to provide demand ventilation indoor air quality (IAQ) control.
 - b. The IAQ sensor shall be available in duct mount, wall mount, or wall mount with LED display. The setpoint shall have adjustment capability.
18. Smoke Detectors:
 - a. Shall be a 4-wire controller and detector.
 - b. Shall be environmental compensated with differential sensing for reliable, stable, and drift-free sensitivity.
 - c. Shall use magnet-activated test/reset sensor switches.
 - d. Shall have tool-less connection terminal access.
 - e. Shall have a recessed momentary switch for testing and resetting the detector.
 - f. Controller shall include:
 - 1) One set of normally open alarm initiation contacts for connection to an initiating device circuit on a fire alarm control panel.
 - 2) Two Form-C auxiliary alarm relays for interface with rooftop unit or other equipment.
 - 3) One Form-C supervision (trouble) relay to control the operation of the Trouble LED on a remote test/reset station.
 - 4) Capable of direct connection to 2 individual detector modules.
 - 5) Can be wired to up to 14 other duct smoke detectors for multiple fan shut-down applications.
19. Winter Start Kit:
 - a. Shall contain a bypass device around the low pressure switch.
 - b. Shall be required when mechanical cooling is required down to 40°F (4°C).
 - c. Shall not be required to operate on an economizer when below an outdoor ambient of 40°F (4°C).
20. Time Guard:
 - a. Shall prevent compressor short-cycling by providing a 5 minute delay (±2 minutes) before restarting a compressor after shut-down for any reason.
 - b. One device shall be required per compressor.
21. Disconnect Switch Bracket (size 180 only):
 - a. Provides a pre-engineered and sized mounting bracket for applications requiring a unit mounted fused and non-fused disconnect of greater than 100 amps. Bracket assures that no damage will occur to coils when mounting with screws and other fasteners.
22. Hinged Access Panels:
 - a. Shall provide easy access through integrated quarter turn latches.
 - b. Shall be on major panels of: filter, control box, fan motor, and compressor.
23. Condensate Overflow Switch:

This sensor and related controller monitors the condensate level in the drain pan and shuts down compression operation when overflow conditions occur. It includes:

 - a. Indicator light — solid red (more than 10 seconds on water contact — compressors disabled), blinking red (sensor disconnected).
 - b. 10 second delay to break — eliminates nuisance trips from splashing or waves in pan (sensor needs 10 seconds of constant water contact before tripping).
 - c. Disables the compressors operation when condensate plug is detected, but still allows fans to run for economizer.
24. 4 in. Return Air Rack (field-installed only):
 - a. Accessory kit is designed to hold 4 in. MERV-8 or MERV-13 filters. Filters not included with kit.
 - b. Shall not be compatible with horizontal units with field-installed economizers.
25. Phase Monitor Control (field-installed only):
 - a. Shall monitor the sequence of 3-phase electrical system to provide a phase reversal protection.
 - b. Shall monitor the 3-phase voltage inputs to provide a phase loss protection for the three phase device.
 - c. Will work on either a Delta or Wye power connection.
26. Horn/Strobe Annunciator:
 - a. Provides an audible/visual signaling device for use with factory-installed option or field installed accessory smoke detectors.
 - b. Requires installation of a field-supplied 24-v transformer suitable for 4.2 VA (AC) or 3.0 VA (DC) per horn/strobe accessory.
 - c. Requires field-supplied electrical box, North American 1-gang box, 2 in. x 4 in. (51 mm x 102 mm).
 - d. Shall have a clear colored lens.

Guide specifications — RAF (cont)

27. Electric Heat:

a. Heating Section:

- 1) Heater element open coil resistance wire, nickel-chrome alloy, 0.29-in. inside diameter, strung through ceramic insulators mounted on metal frame. Coil ends are staked and welded to terminal screw slots.
- 2) Heater assemblies are provided with integral fusing for protection of internal heater circuits. Auto re-set thermo limit controls, magnetic heater contactors (24-v coil) and terminal block all mounted in electric heater control box

(minimum 18 ga galvanized steel)
attached to end of heater assembly.

28. High Short Circuit Current Rating (SCCR) Protection:

- a. Factory-installed option shall provide high short circuit current protection to compressor and all indoor and outdoor fan motors rated at 10 kA against high potential fault current situations. (Standard unit comes with 5 kA rating.)
- b. This option is not available with factory installed Hot Gas Re-Heat system, powered convenience outlet, non-fused disconnect, low ambient controls, phase loss monitor/protection, and 575-v models.